

# **LAPPSET®**

## **FITNESS**

ASENNUSOHJE  
MONTERINGSANSVISNING  
INSTALLATION INSTRUCTION  
AUFBAUANLEITUNG  
NOTICE D'INSTALLATION

DATE: 16.12.2021







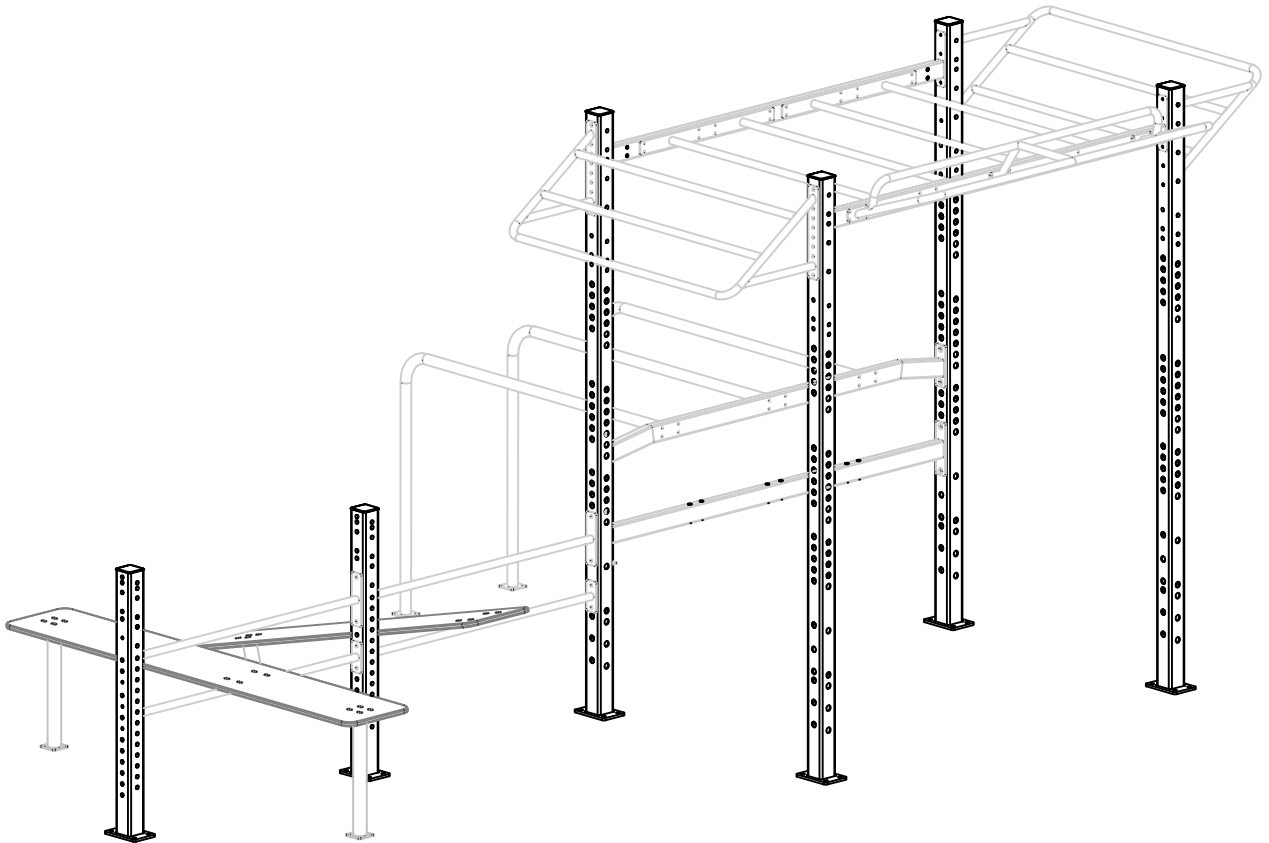



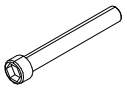



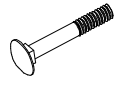

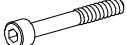
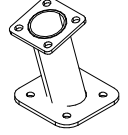



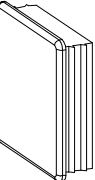

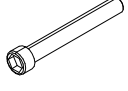
Fitness equipment is not intended for installation in the immediate vicinity of children's playgrounds in accordance with EN 1176.

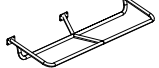
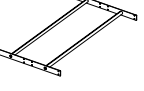
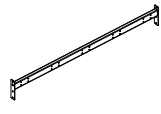
Kuntolaitteita ei ole tarkoitettu asennettaviksi lasten leikkikentän välittömään läheisyyteen standardin EN 1176 mukaisesti.

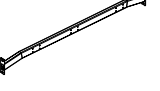
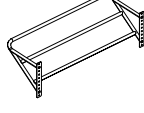
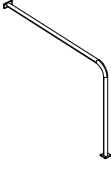
## **Q13526**

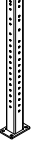

DATE: 22.12.2021

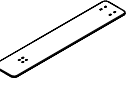
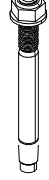
702341  90x50	PCS 1	902096  M12x120	PCS 24	902454 	PCS 4	902564  L 550	PCS 2	906598 	PCS 2	909107  M12x80	PCS 8
909109  M12x40	PCS 12	909205  M8x60	PCS 48	909514  130x130x174	PCS 1	909628  M10x100	PCS 24	909633  M8	PCS 48	909644  M12	PCS 58
910376  Ø30x17	PCS 16	910405  90x90x30	PCS 6	910415  Ø16/12,5-14x17	PCS 233	910467  Ø13-Ø9x7	PCS 8	912127  M12x110	PCS 14	980151  Ø16/8.4	PCS 136
980154  Ø24/13	PCS 106	910392-217 	PCS 1	910402-217 	PCS 2	910408-207 	PCS 2	910410-207  90x90x2720	PCS 4	910431-217 	PCS 1
910436-217 	PCS 2	910441-217 	PCS 3	910622-217 	PCS 2	910655-207  Ø24/13	PCS 2	911012-217  80x40x1990	PCS 1	911016-217  1315x240	PCS 2
P01986 	PCS 1	P01987 	PCS 1	904450  M16x170	PCS 24		PCS		PCS		PCS
	PCS		PCS		PCS		PCS		PCS		PCS

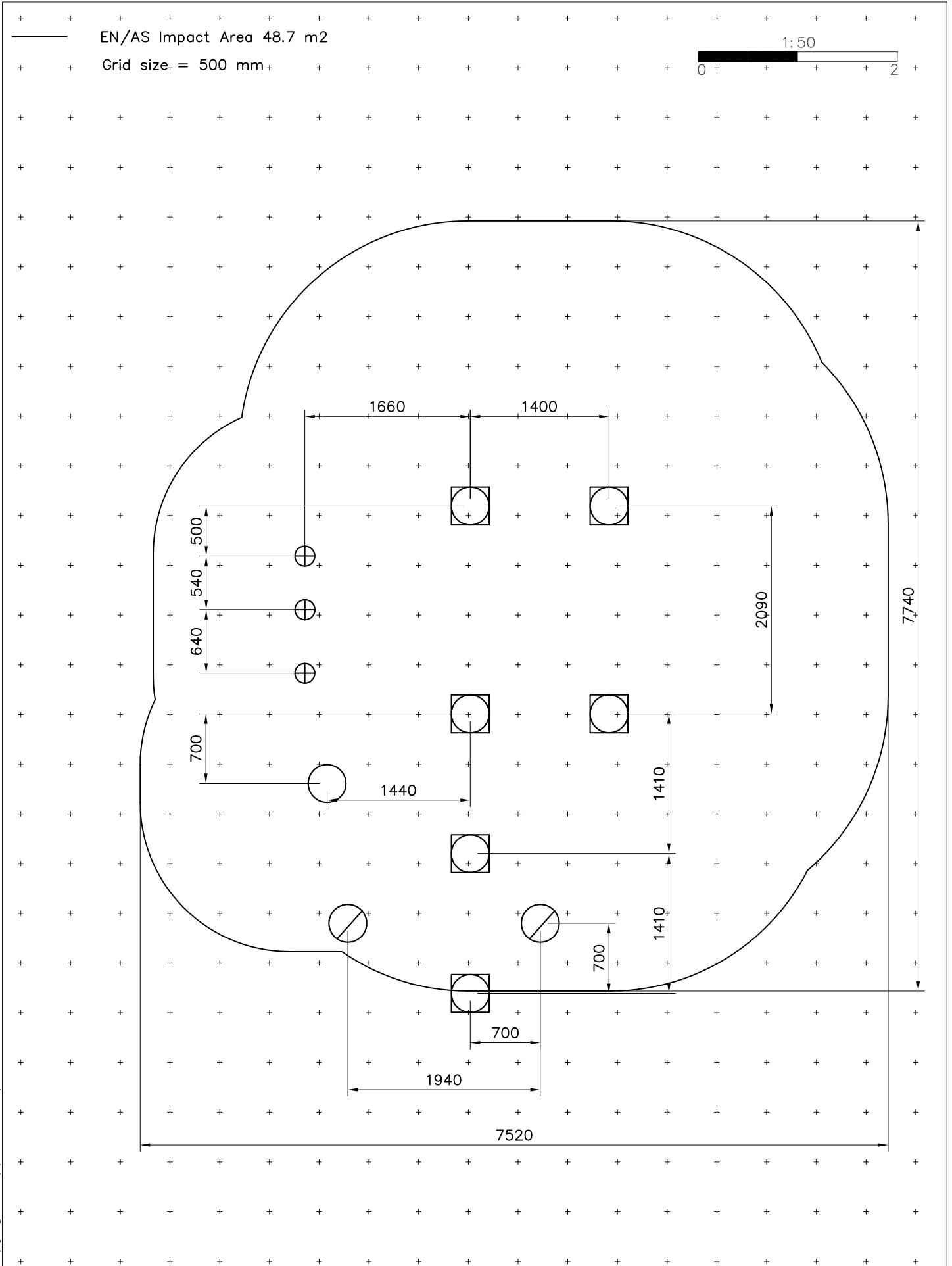

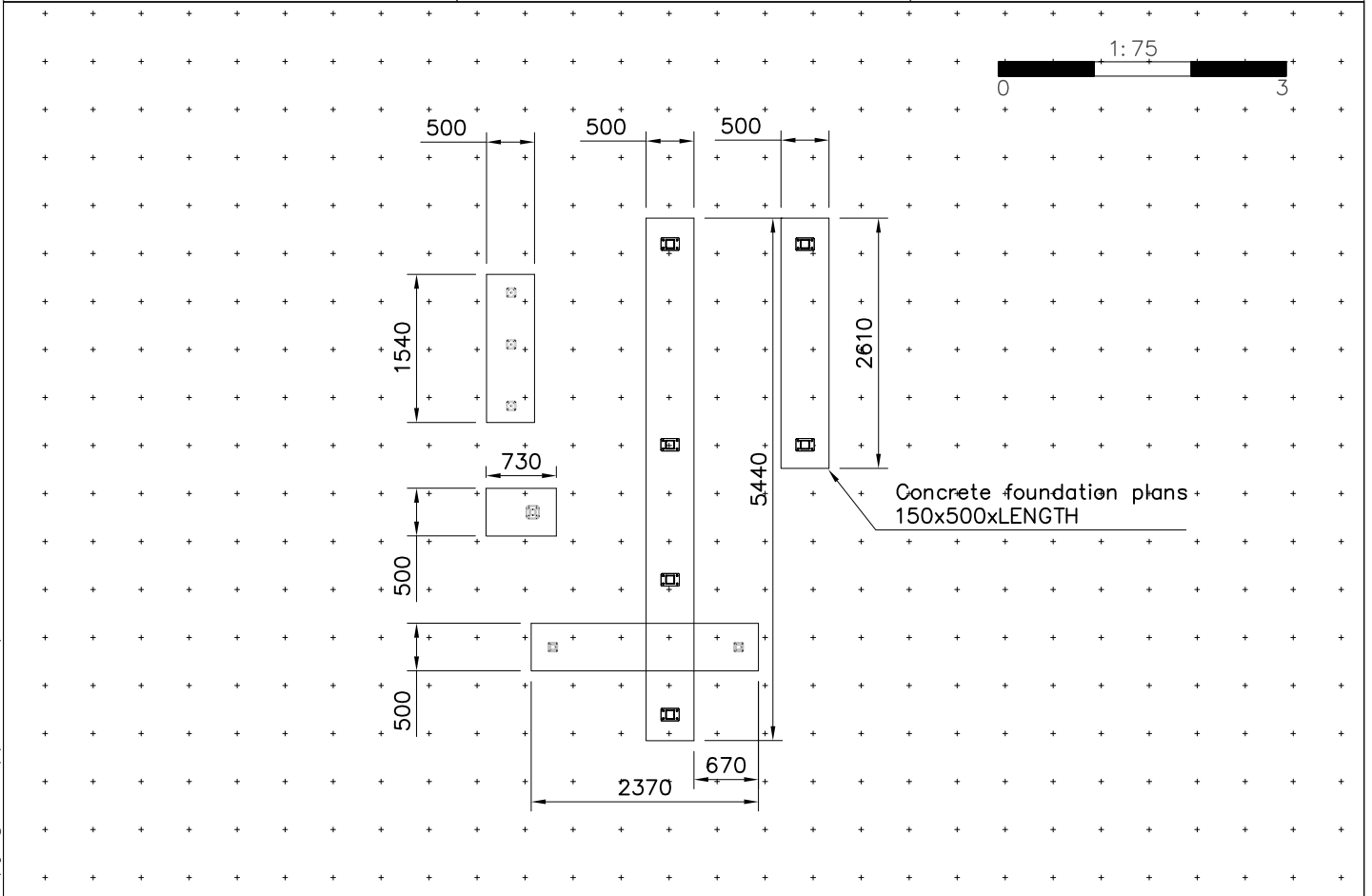
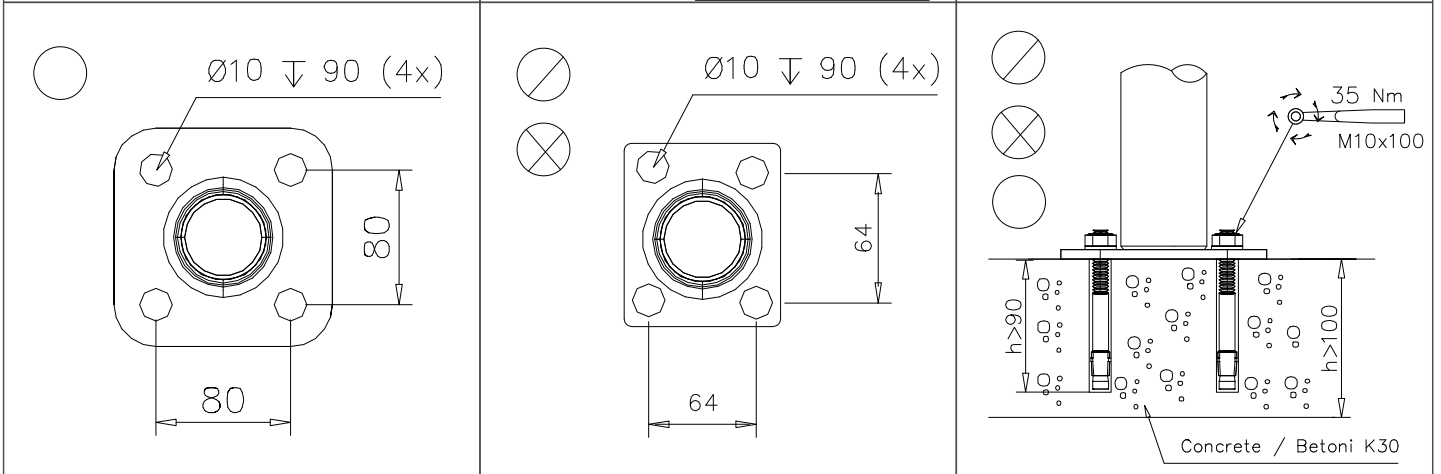
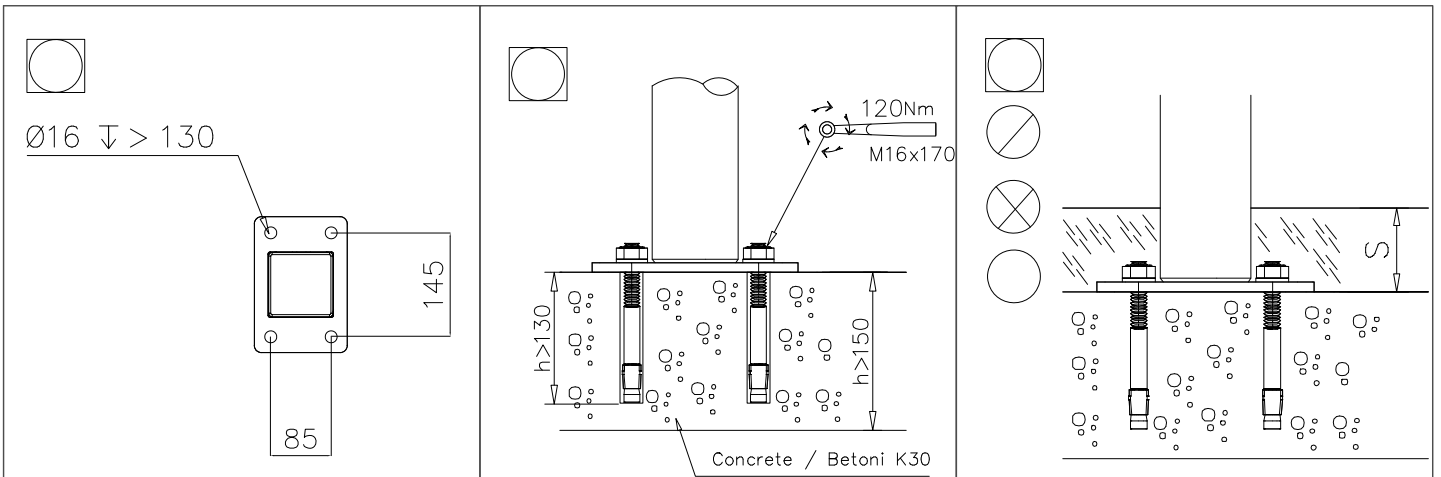

- Area of Movement 48.7 m<sup>2</sup>
- - - Movement Space 54 m<sup>2</sup>
- - - - Training Space 19.3 m<sup>2</sup>
- Max Falling Height 2700 mm

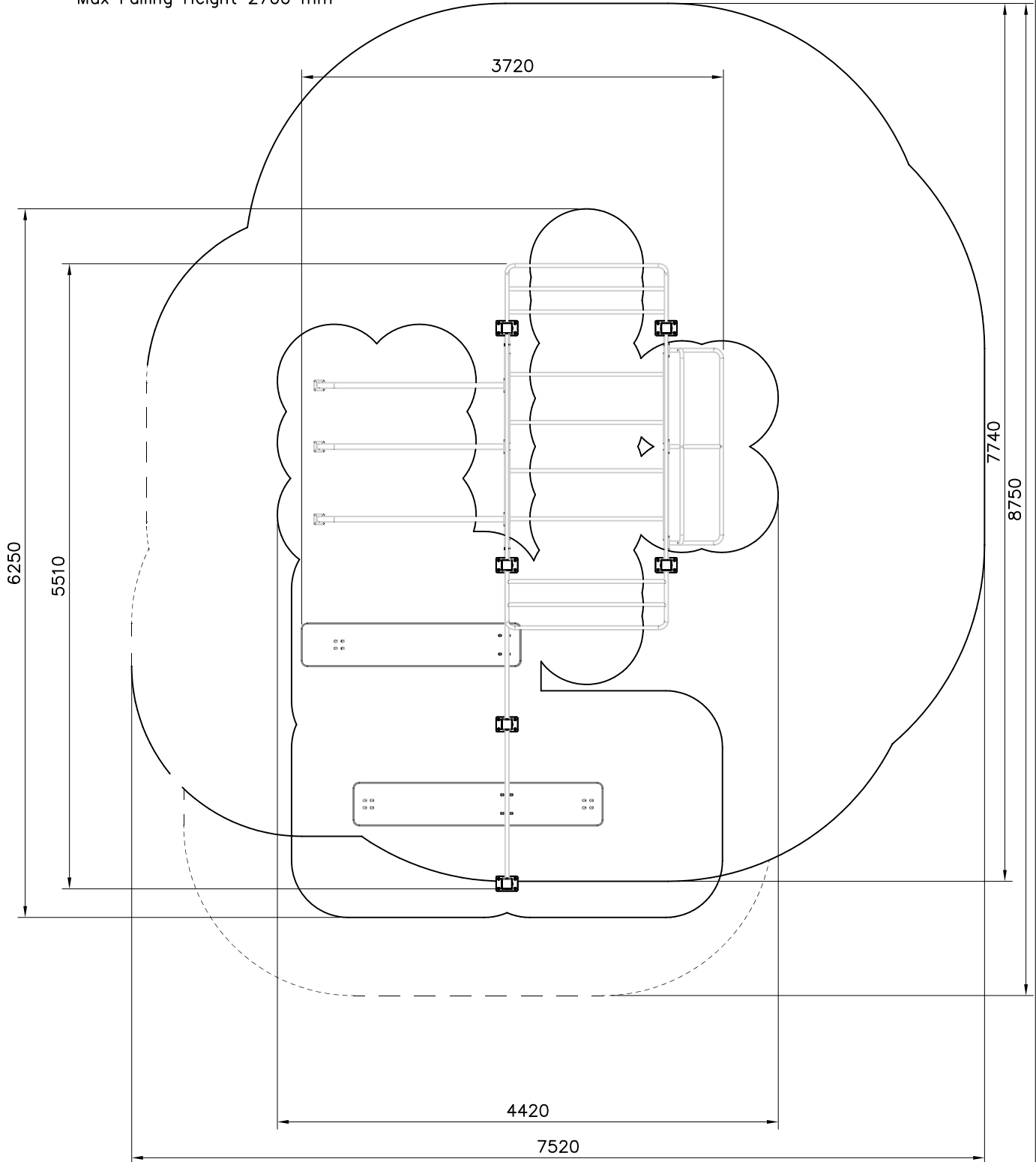
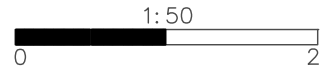

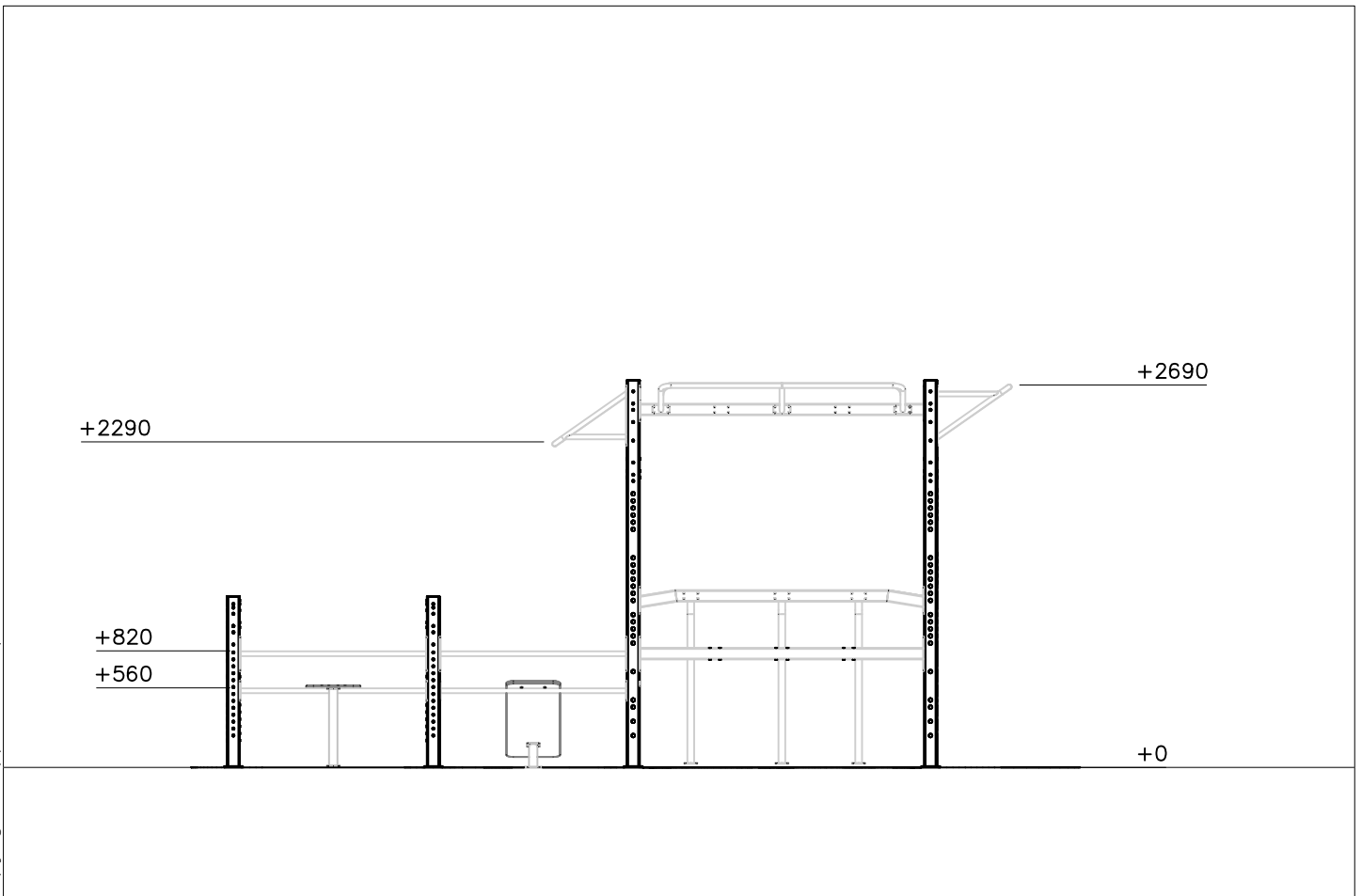
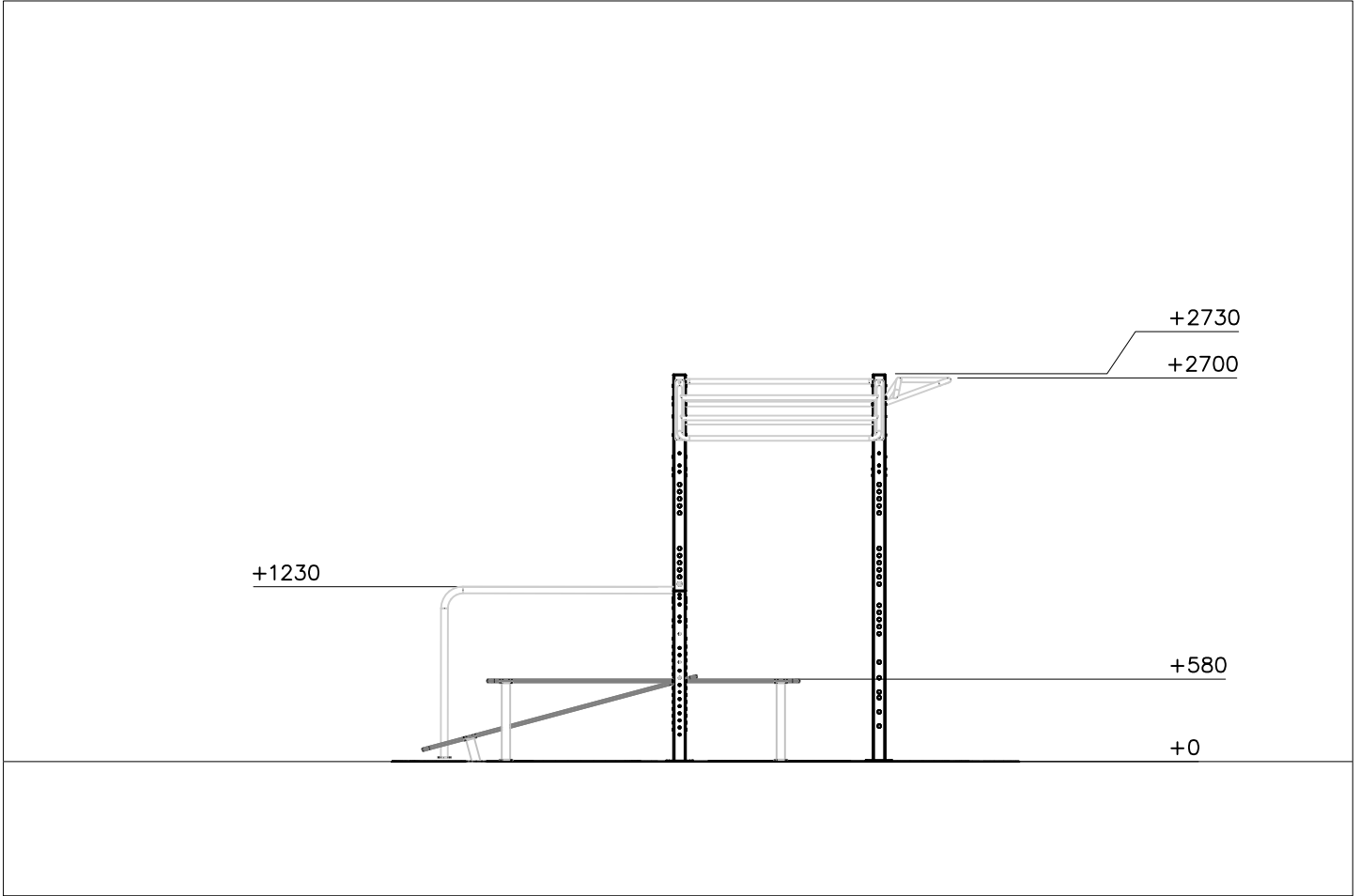

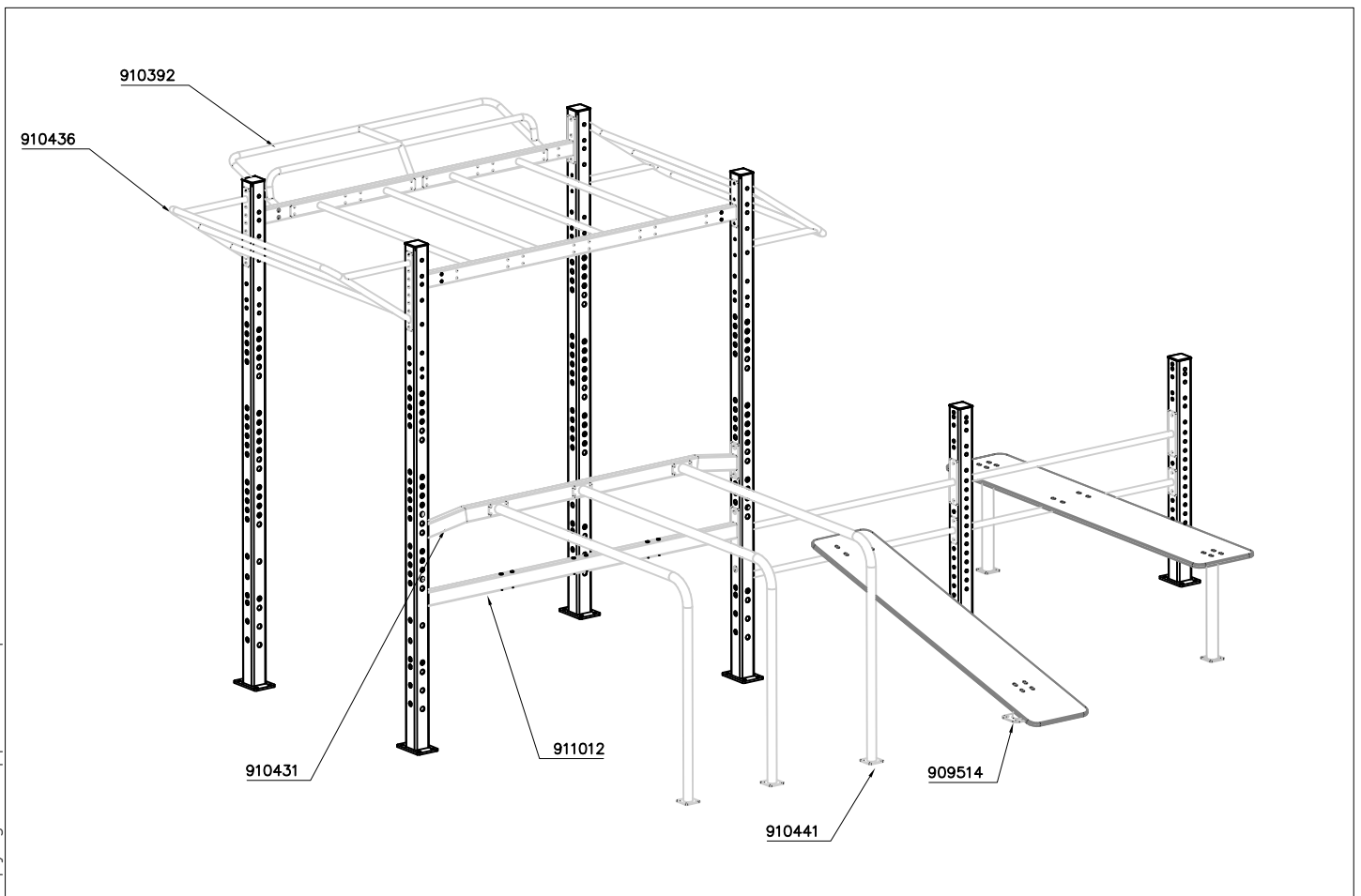
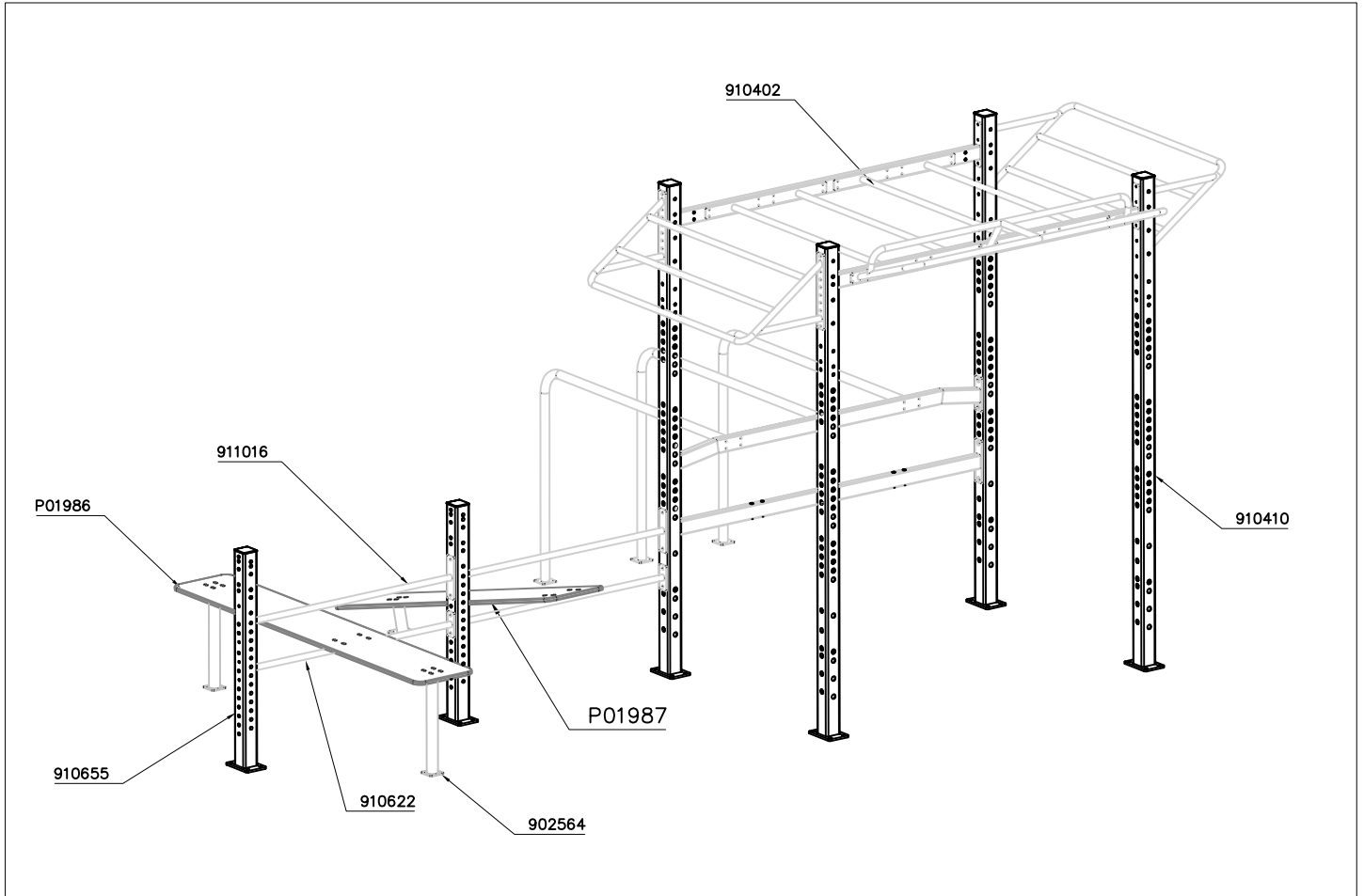

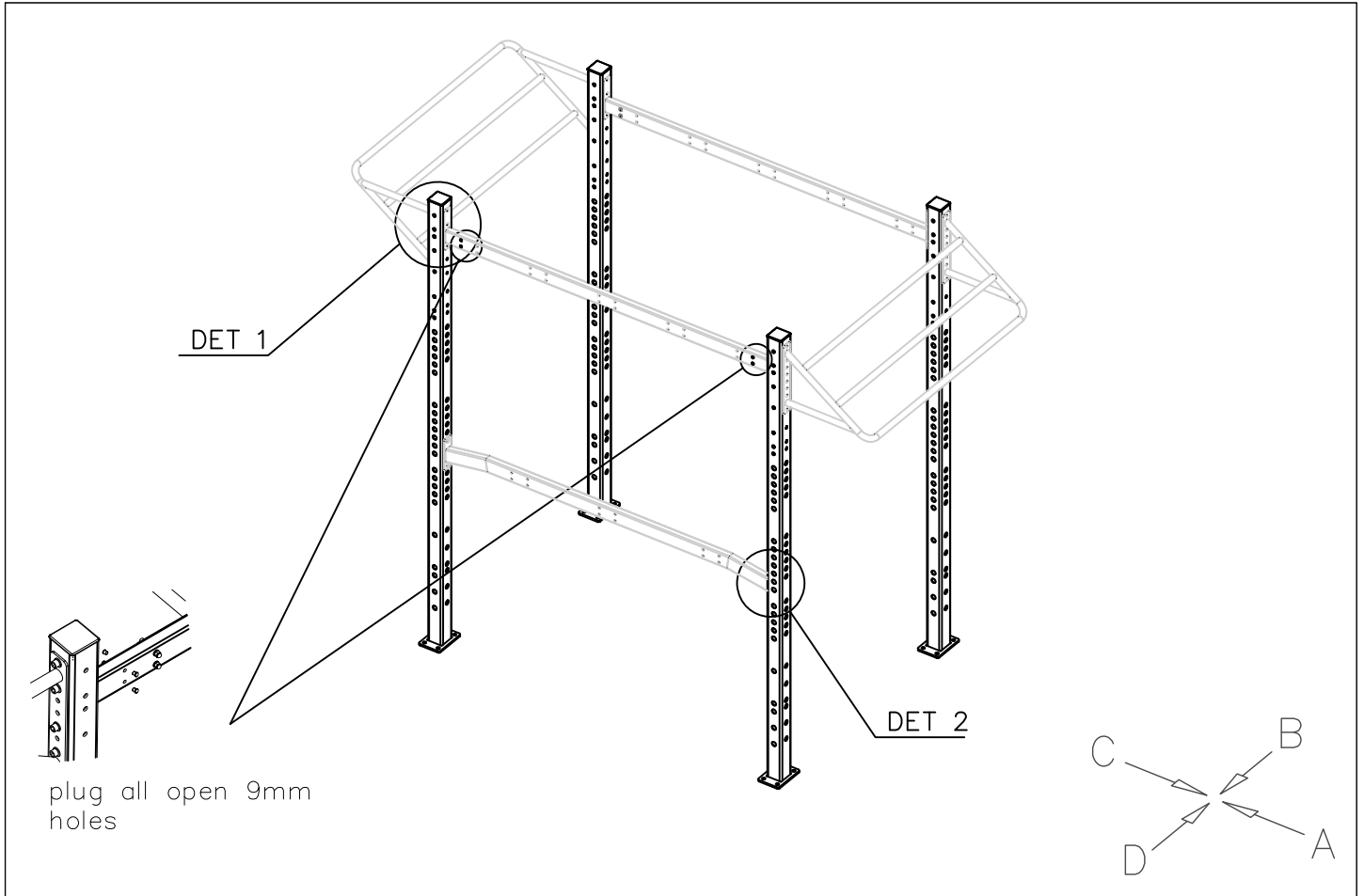

DET 1

DET 2

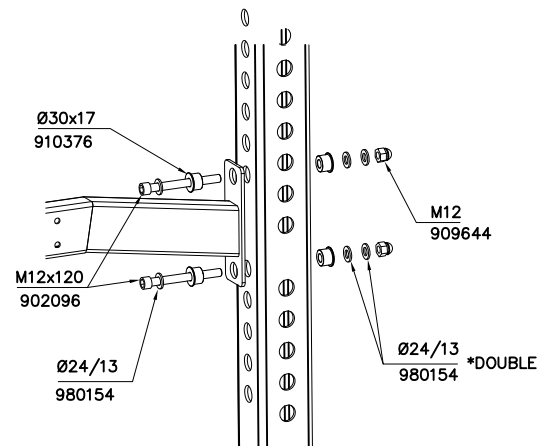
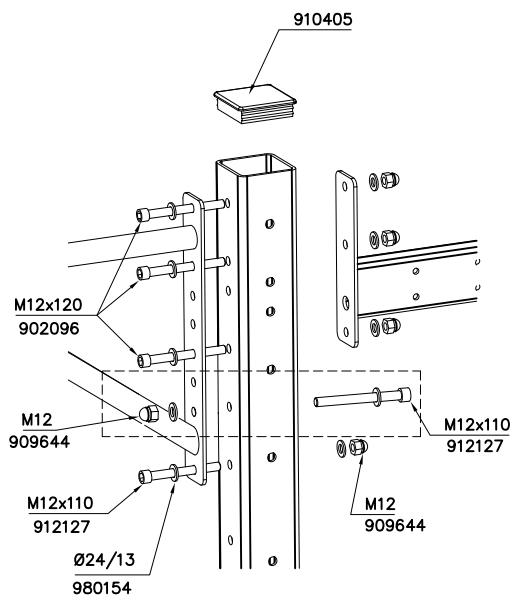



DATE: 16.12.2021

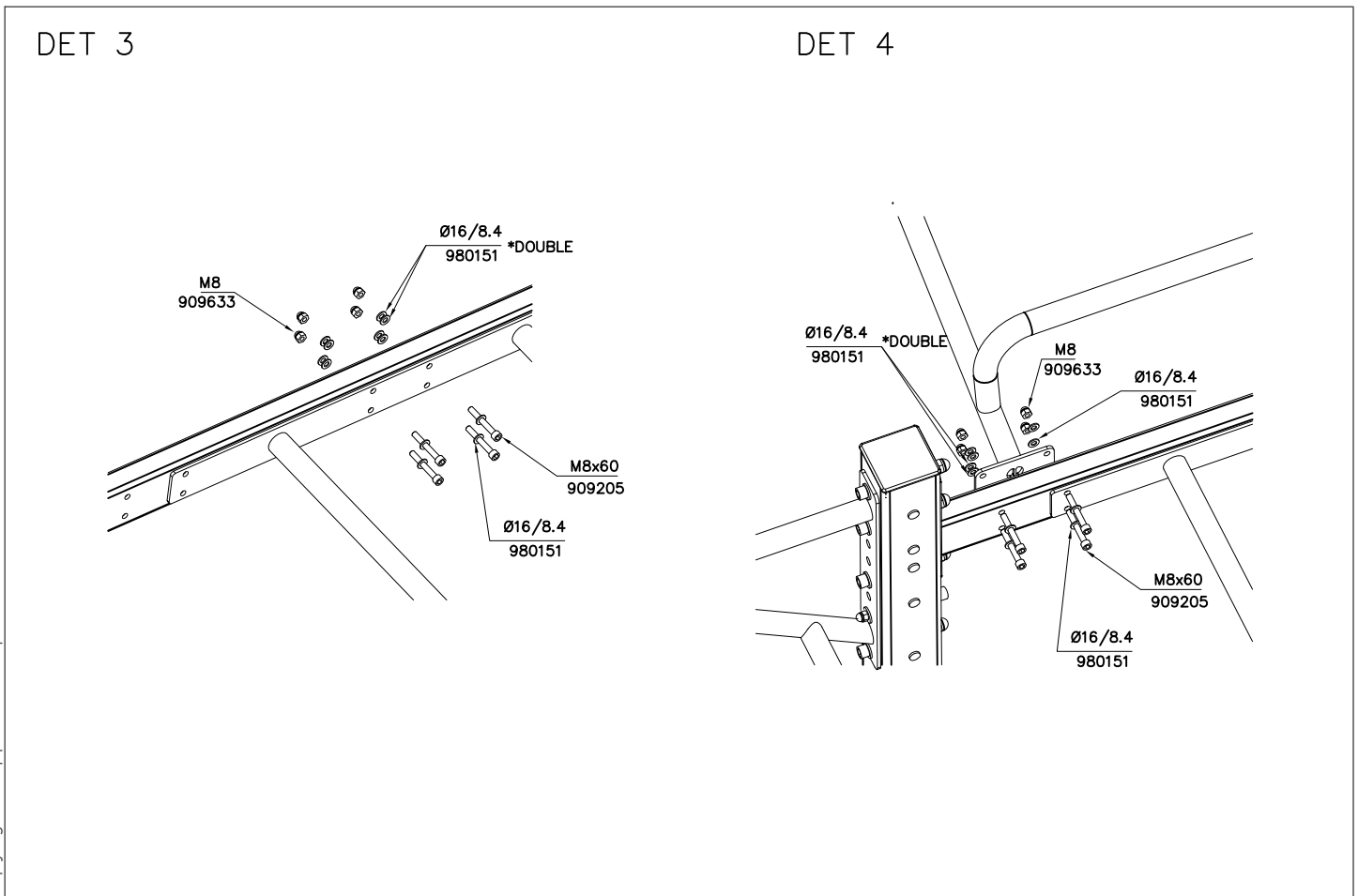
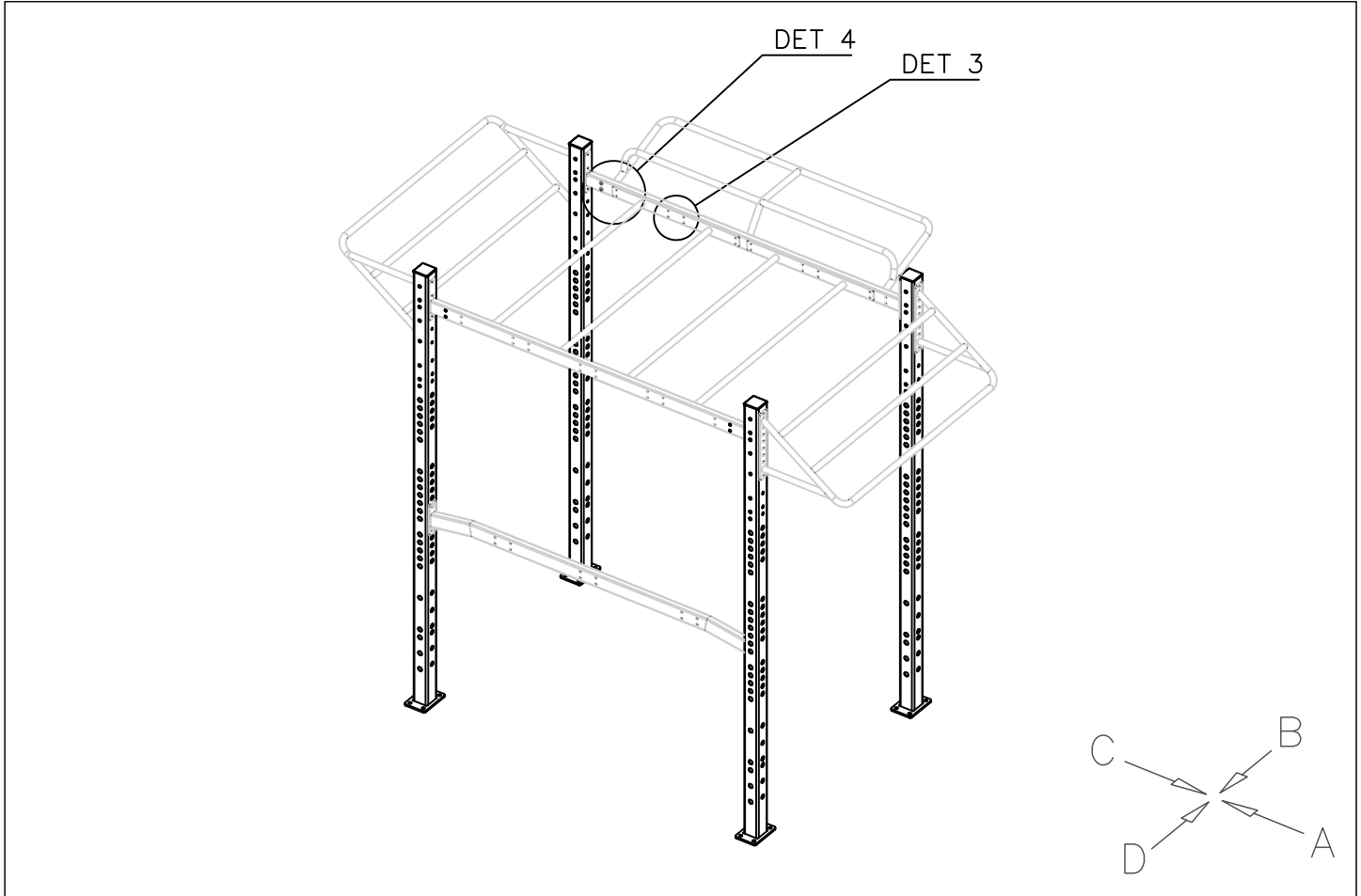

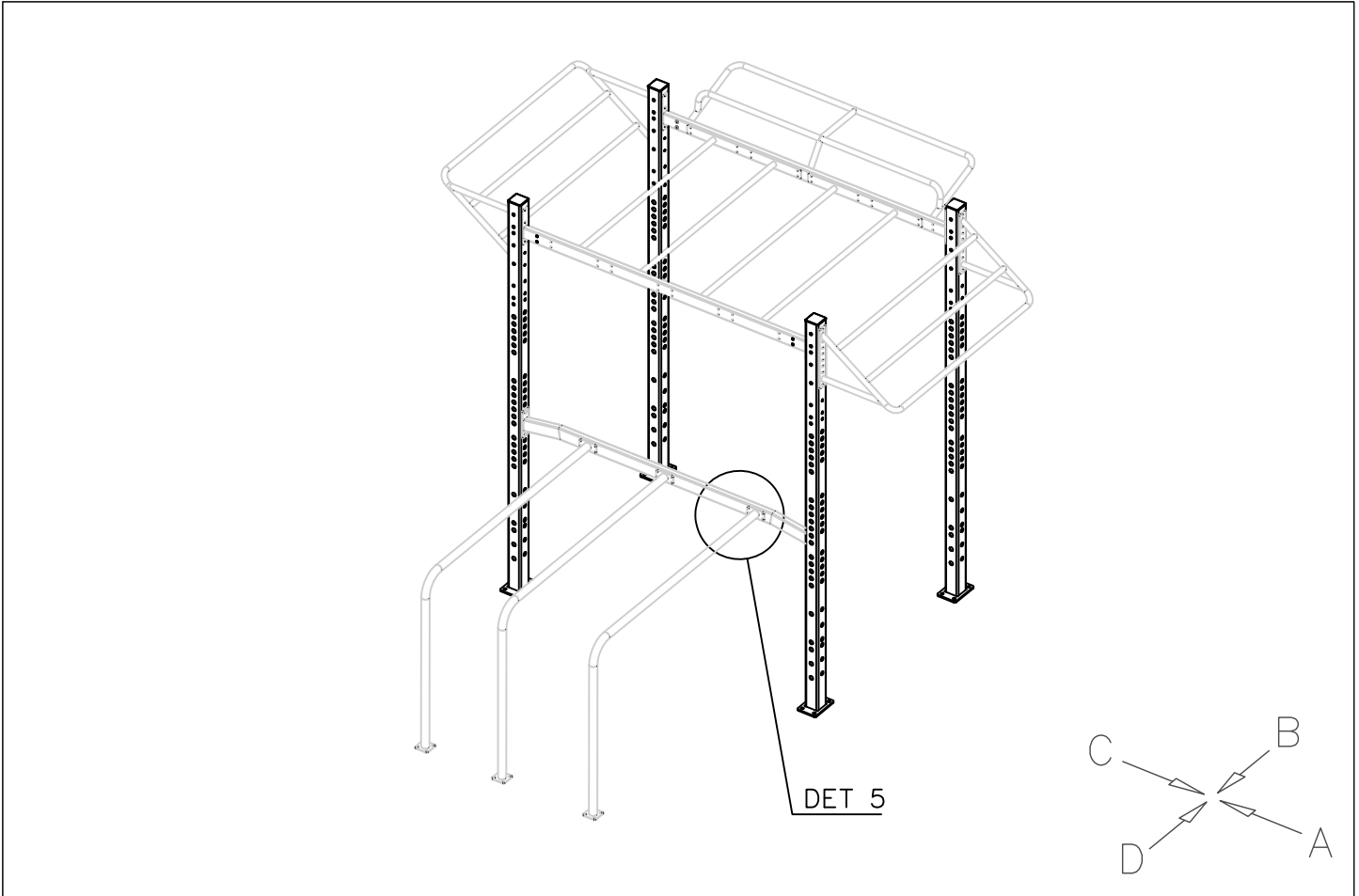

**DET 5**

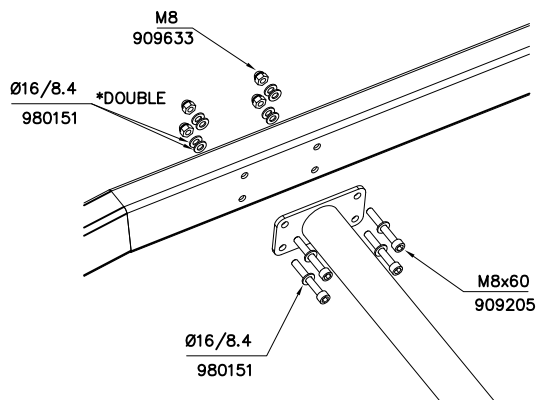

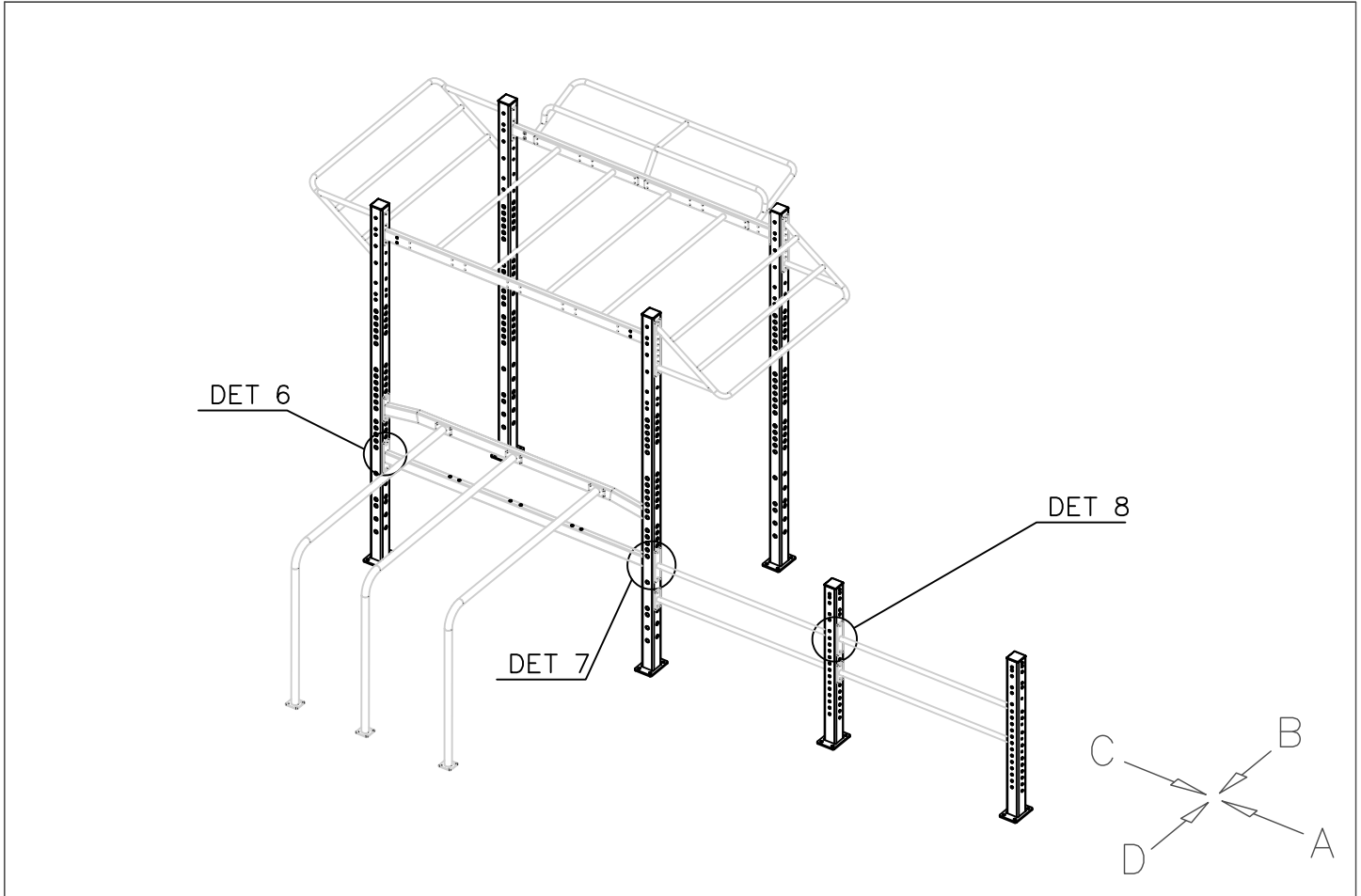

DET 6

DET 7

DET 8

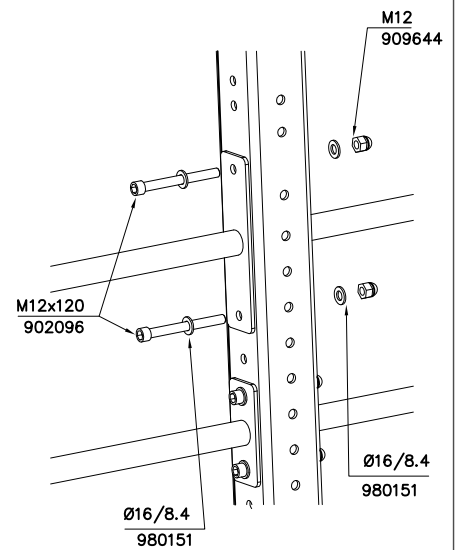
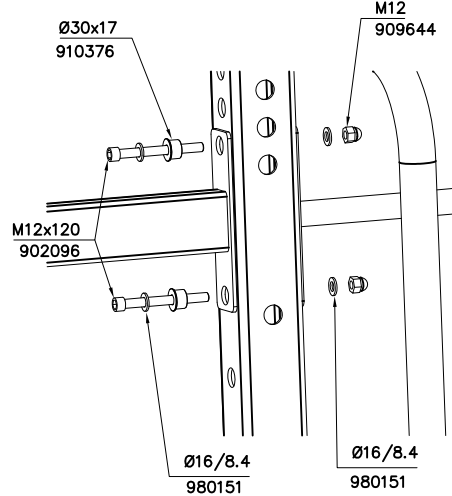
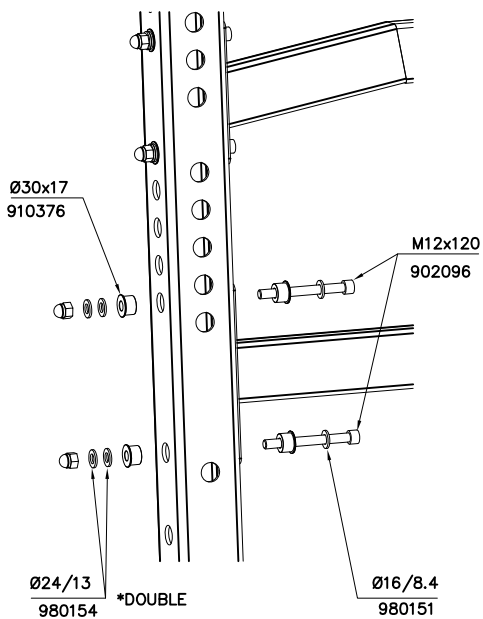

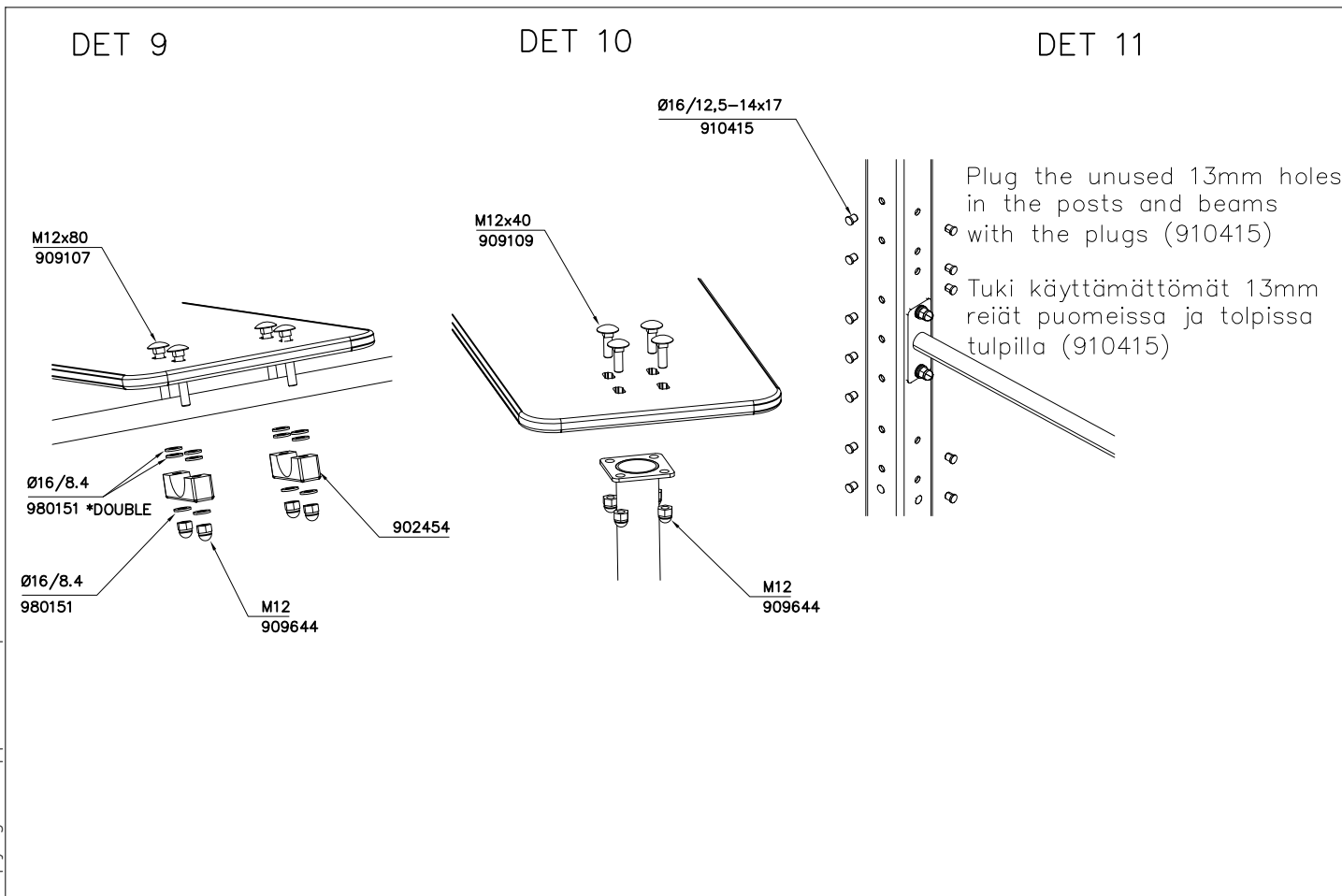
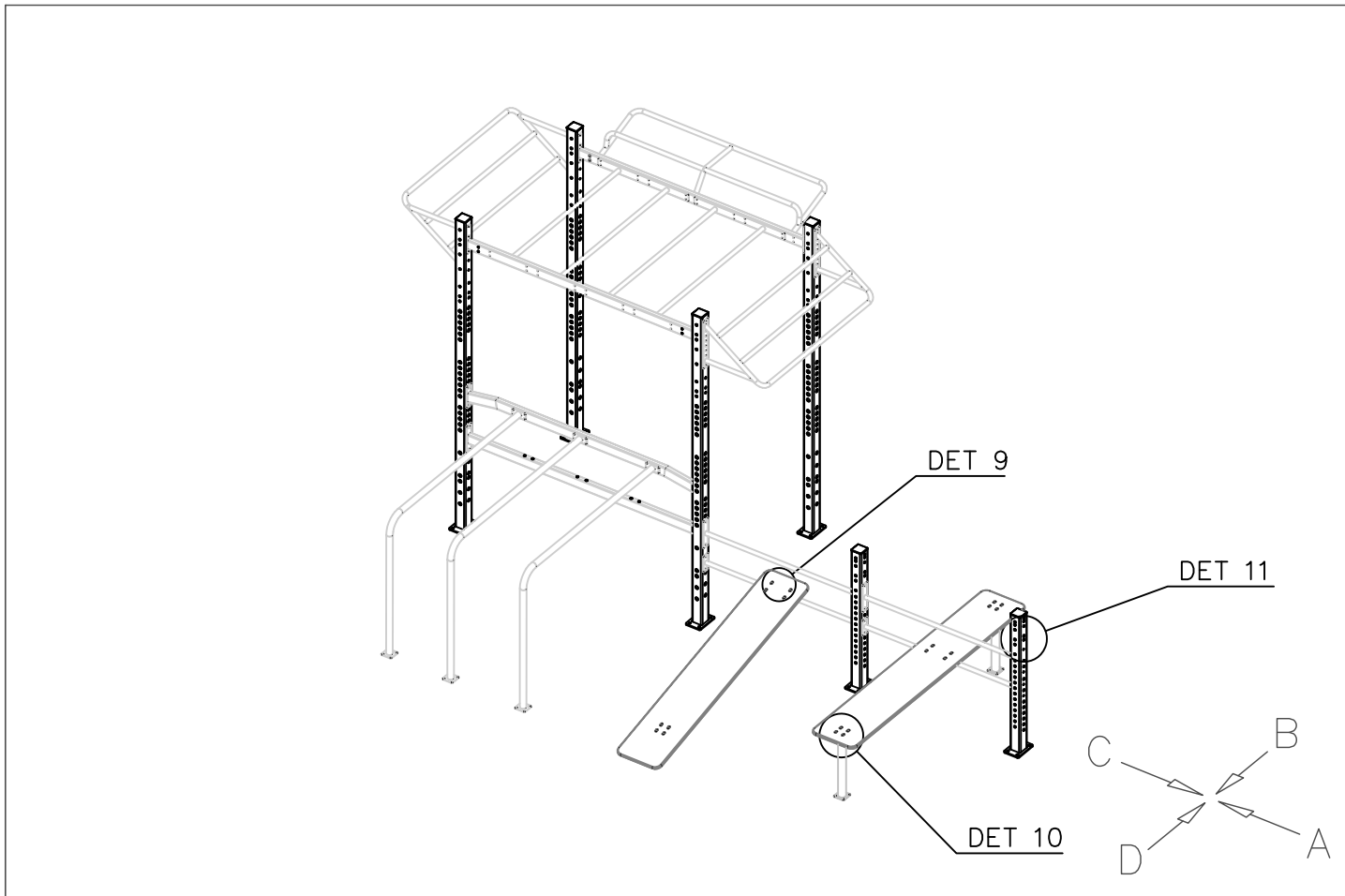

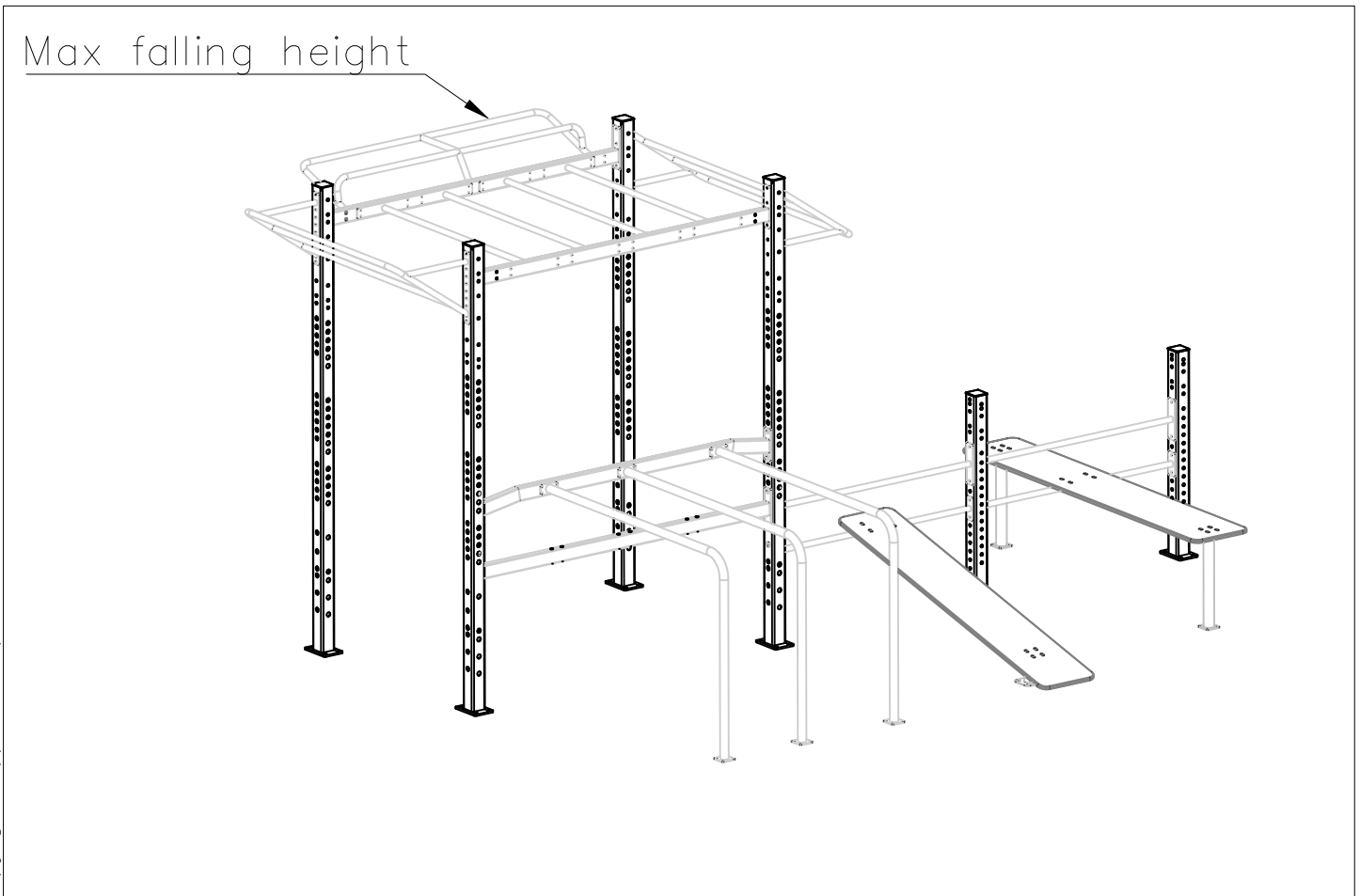
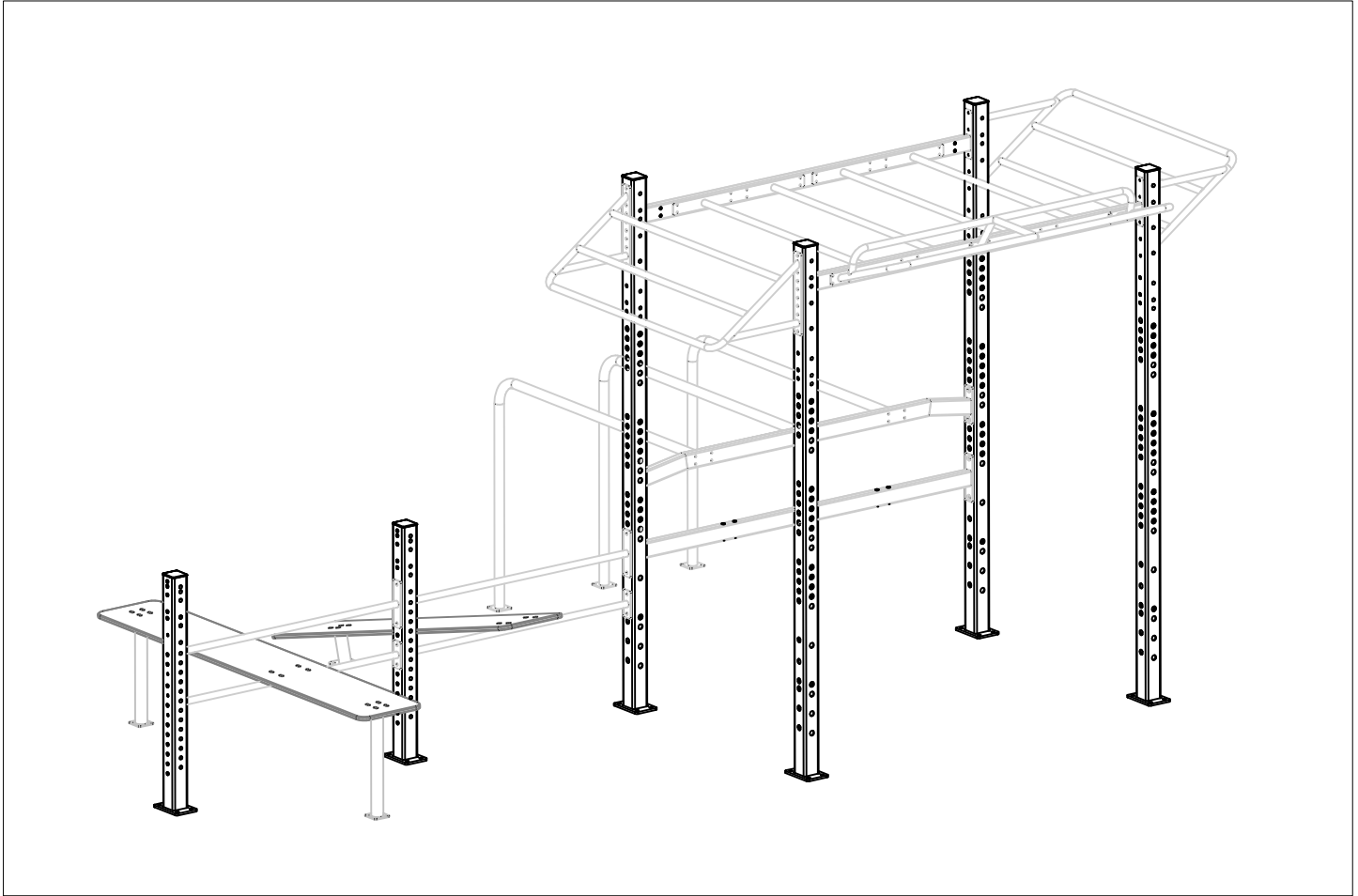

# LAPPSET® SURF. FOUNDATION

# FOOT

DATE: 13.5.2014

4A

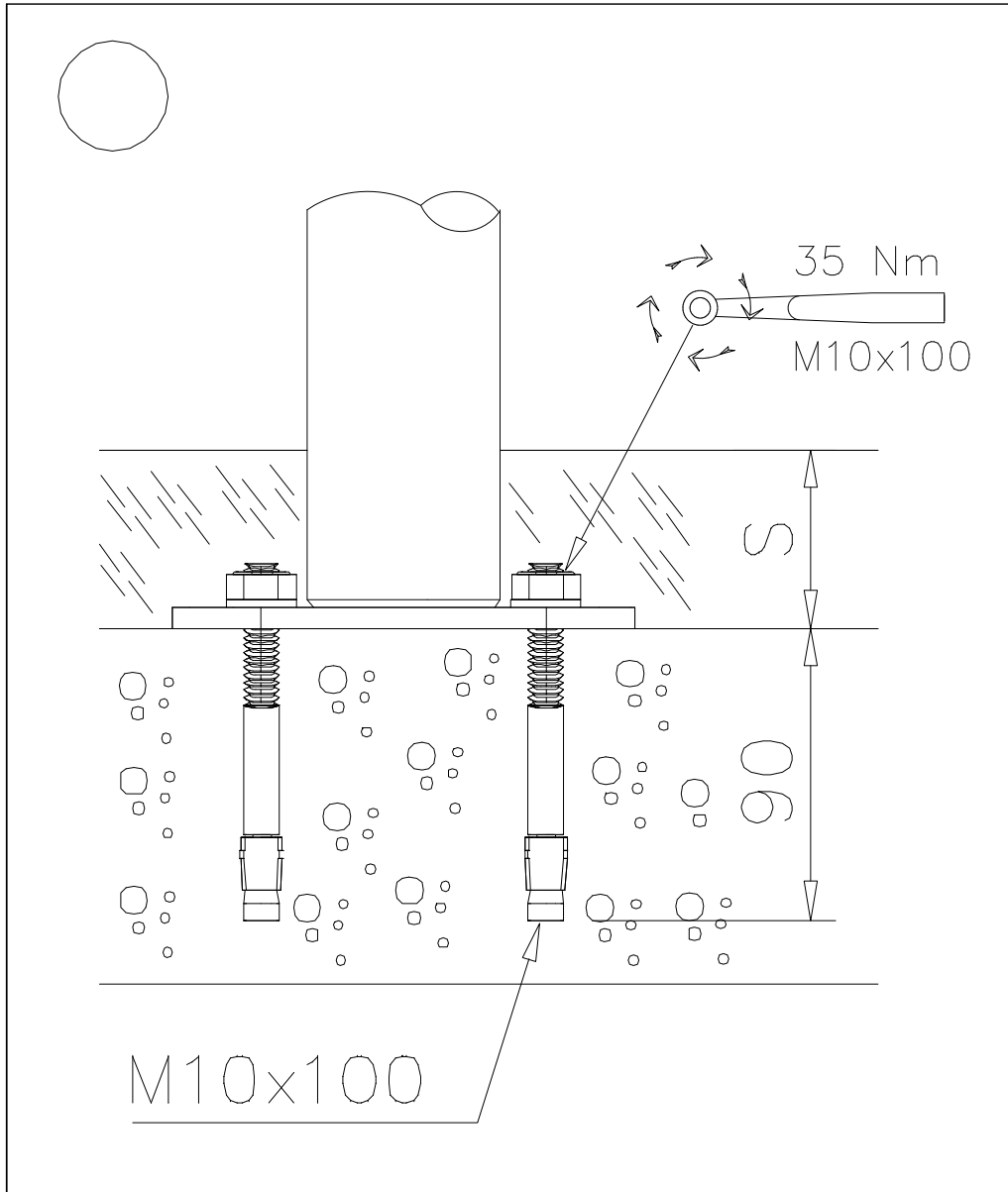

① 909531	PCS	② 909628	PCS
	1		4
130x130x150		M10x100	
③ 905104	PCS		PCS
	4		
M10			
	PCS		PCS
	PCS		PCS
	PCS		PCS

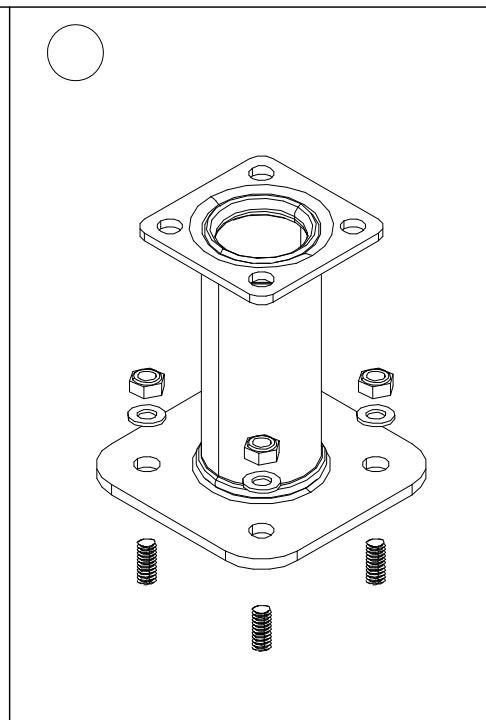
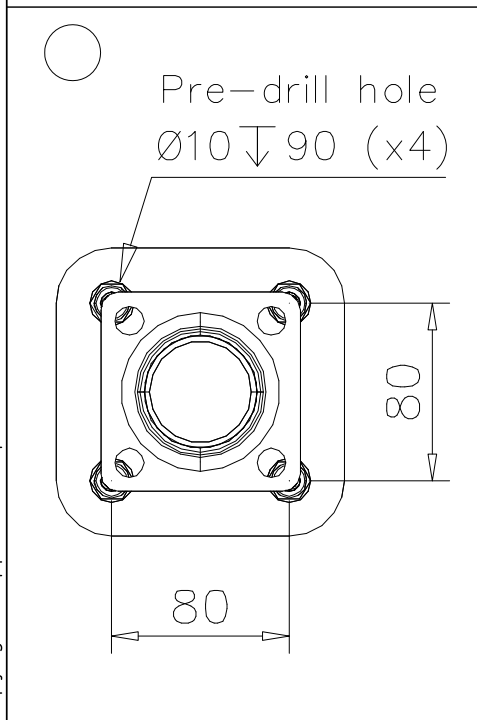

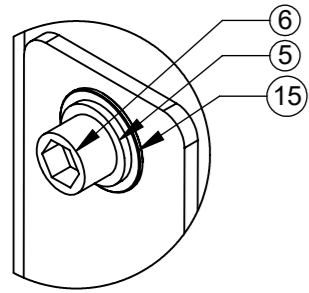

DETAIL D 1 : 2

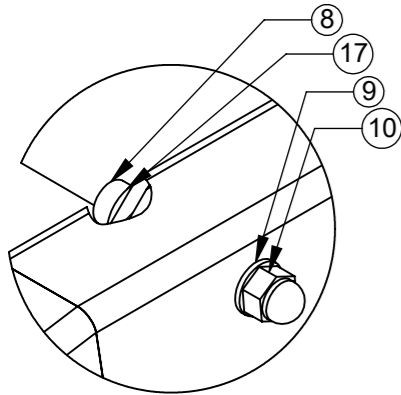

DETAIL C 1 : 2

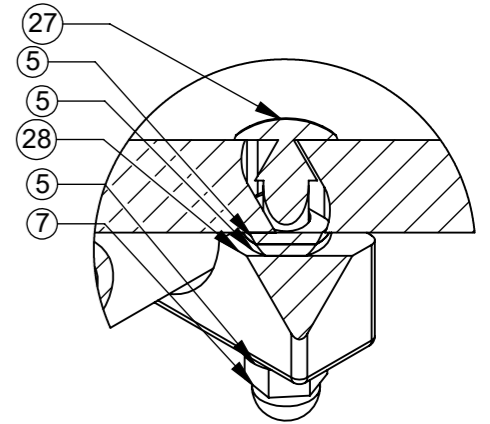

DETAIL B 1 : 2

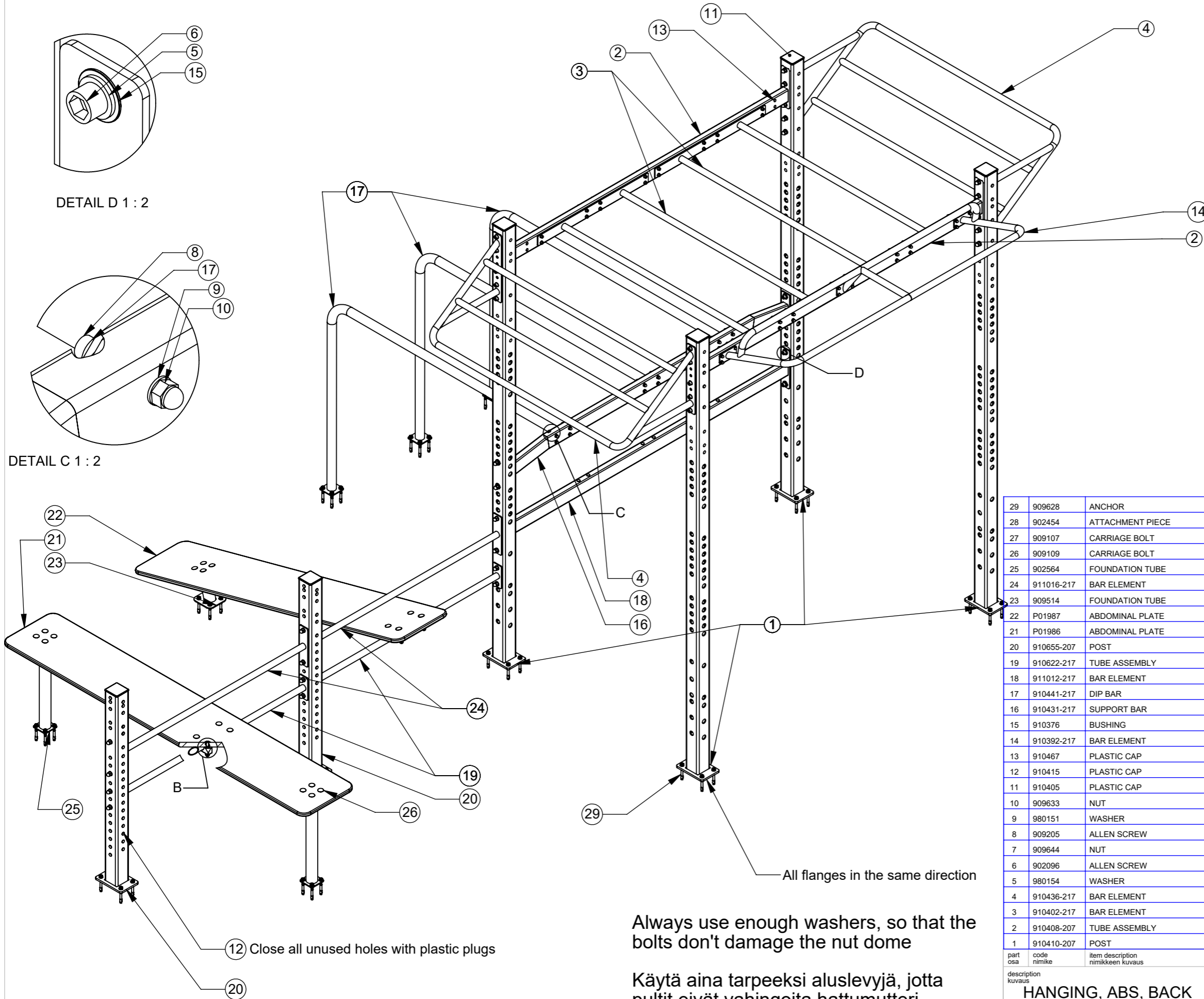

12 Close all unused holes with plastic plugs

Always use enough washers, so that the bolts don't damage the nut dome

Käytä aina tarpeeksi aluslevyjä, jotta pultit eivät vahingoita hattumutteri.

29	909628	ANCHOR	M10x100	48		ZN
28	902454	ATTACHMENT PIECE		4		
27	909107	CARRIAGE BOLT	M12x80	8		DIN 603 ZNK 4,6
26	909109	CARRIAGE BOLT	M12x40	12		DIN 603 ZNK 4,6
25	902564	FOUNDATION TUBE	550	2		
24	911016-217	BAR ELEMENT	1315x240	2		
23	909514	FOUNDATION TUBE	130x130x174	1		
22	P01987	ABDOMINAL PLATE		1		LAMINATE
21	P01986	ABDOMINAL PLATE		1		LAMINATE
20	910655-207	POST	90x90x1200	2		
19	910622-217	TUBE ASSEMBLY	1315	2		
18	911012-217	BAR ELEMENT	80x40x1990	1		
17	910441-217	DIP BAR	1500x1156	3		
16	910431-217	SUPPORT BAR	80x40	1		
15	910376	BUSHING	Ø30x17	16		ROUND BAR
14	910392-217	BAR ELEMENT	Ø33,7	1		
13	910467	PLASTIC CAP	Ø13-Ø9x7	8		
12	910415	PLASTIC CAP	Ø16/12,5-14x17	229		
11	910405	PLASTIC CAP	90x90x30	6		
10	909633	NUT	M8	48		DIN 1587, A2
9	980151	WASHER	Ø16/8,4	96		DIN 125 A HDG
8	909205	ALLEN SCREW	M8x60	48		S355J0
7	909644	NUT	M12	59		A2 (ST. STEEL)
6	902096	ALLEN SCREW	M12x120	38		
5	980154	WASHER	Ø24/13	113		DIN 125 A HDG
4	910436-217	BAR ELEMENT	Ø33,7	2		
3	910402-217	BAR ELEMENT	lime	2		
2	910408-207	TUBE ASSEMBLY	black	2		
1	910410-207	POST	90x90x2720	4		

part osa	code nimike	item description nimike kuvaus	dimension koko	pcs kpl	amount määrä	material / note raaka-aine / lisätieto
description kuvaus				massa	402.257 kg	phase tila
HANGING, ABS, BACK				turn kääntö		Production Drawing
				item nr nimike nro		Q13526
revision revisio nro	arkki size	tolerances yleistoleranssi				
1	A3	page sivu	1/1	date päiväys	name nimi	
scale suhde	des. suun.	05.02.19		AJO		
1:1	check tark.	30.09.19		MIKO		



TEL +358 20 775 0100  
FAX +358 20 775 0101

www.lappset.com

PL 8146  
FI-96101 ROVANIEMI

date  
päiväys

name  
nimi

note  
huom.

Alteration  
Muutoskenttä

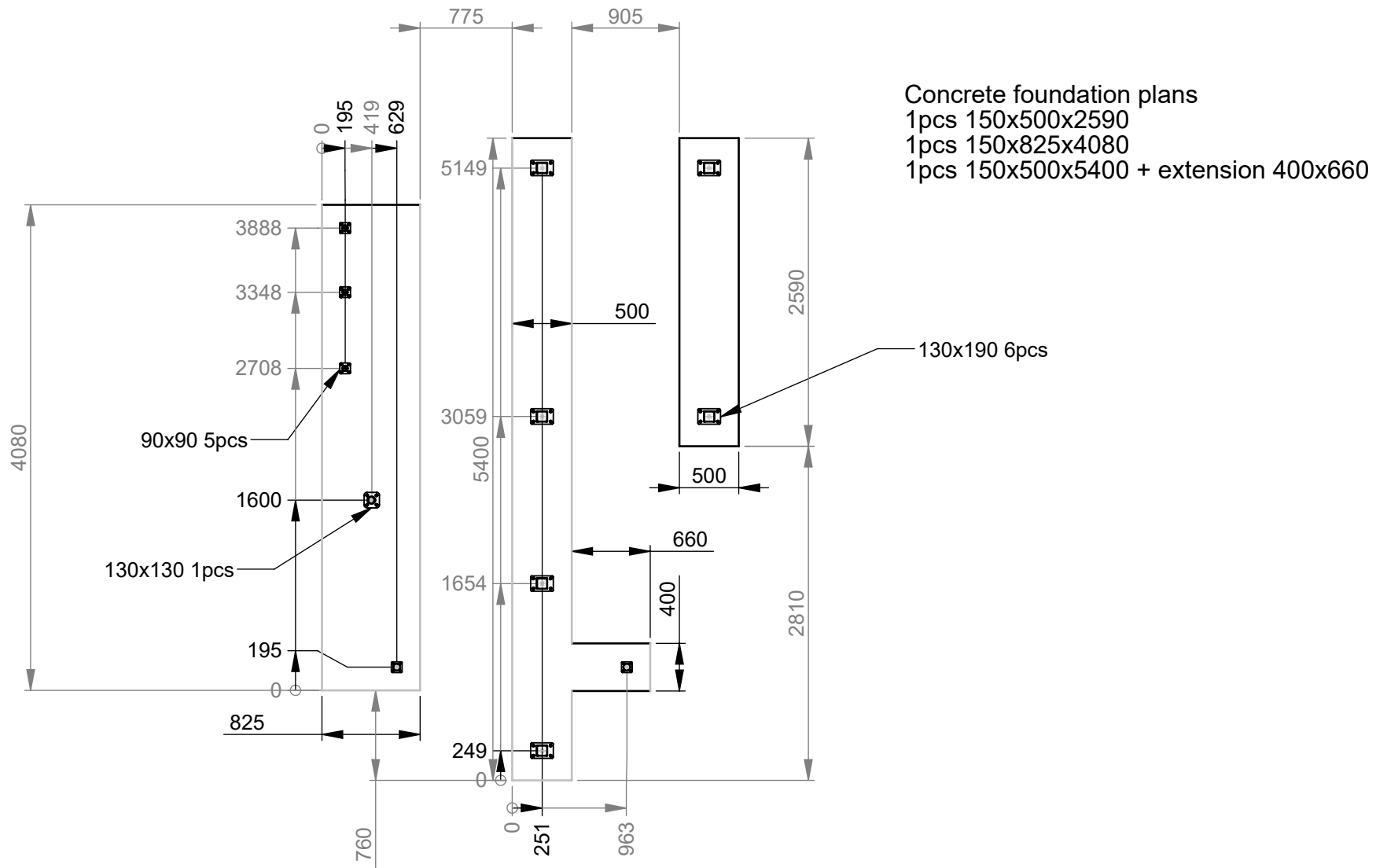

Concrete foundation plans  
 1pcs 150x500x2590  
 1pcs 150x825x4080  
 1pcs 150x500x5400 + extension 400x660

130x190 6pcs

90x90 5pcs

130x130 1pcs

part osa	code nimike	item description nimikkeen kuvaus	dimension koko	pcs kpl	amount määrä	material / note raaka-aine / lisätieto
description kuvaus				mass massa	402.257 kg	phase tila
FUNCTIONAL FITNESS FRAME HANGING, ABS, BACK I2				turn kääntö		Production Drawing
				revision revisio nro	1	item nr nimike nro
				arkki size	A4	tolerances yleistoleranssi
				page sivu	1/1	date päiväys
				scale suhde	1:1	name nimi
				des. suun.	05.02.19	AJO
				check tark.	30.09.19	MIKO
www.lappset.com				TEL +358 20 775 0100 FAX +358 20 775 0101 PL 8146 FI-96101 ROVANIEMI		



**Tuotekyltti tulee tuotteen mukana yhdellä seuraavista tavoista:****1) Metallinen tuotekyltti ja kiinnitysruuvit**

- Kiinnitä tuotekyltti ruuveilla tolppaan noin 2 metrin korkeuteen kuvan 1 mukaisesti.

**2) Tuotekylttitarra**

- Puhdista maalattu metalli- tai vaneripinta pölystä ja kosteudesta. Liimaa tarra kuvan 2 mukaisesti.
- Huom. Älä kiinnitä tarraa karheapintaiseen laminaattiin tai maalattuun puuhun.

**Vår produktmärkning levereras på ett av följande sätt:****1) Produktskylt i metall**

- Fäst skylten med de medföljande skruvarna

**2) Självhäftande produktetikett**

- Rengör den pulverlackerade metallytan eller laminatyten så att den blir fri från smuts och fukt. Fäst etiketten enligt fig. 2.
- Obs! Fäst ej etiketten på detaljer med skrovlig yta eller på målat trä.

**Product label is delivered by one of following ways:****1) Metal product label and screws**

- Fasten the label with screws.

**2) Label sticker**

- Clean the painted metal or plywood surface from dirt and moisture. Fasten the sticker as shown in the figure 2.
- Note. Do not attach the sticker to rough surfaced laminate or painted wood.

**La plaque d'informations produit est livrée sous l'une de ces 3 formes :****1) Plaque métallique et vis**

- Fixez la plaque à l'aide des vis.

**2) Etiquette autocollante**

- Avant de coller l'étiquette, nettoyez le composant métallique peint ou la plaque de contreplaqué, de toute saleté. La surface doit être sèche (voir image 2).
- Attention, ne pas coller l'étiquette sur une surface lamellé-collée irrégulière ou sur du bois peint.

**Die Auslieferung des Produktaufklebers erfolgt auf eine dieser Arten:****1) Produkt-Schild aus Metall incl. Schrauben**

- Die Befestigung des Schildes erfolgt mittels der Schrauben.

**2) Aufkleber**

- Entfernen Sie zunächst Schmutz und Feuchtigkeit vom lackierten Metall bzw. von der Holzoberfläche und bringen Sie den Aufkleber wie im Bild oben rechts beschrieben auf den gesäuberten Untergrund auf.
- Beachten Sie: Bringen Sie den Aufkleber nicht auf raues laminiertes oder lackiertes Holz an.