

DET 1

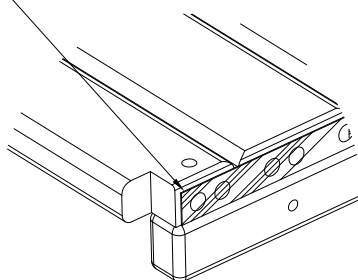

DET 2

Naulanauha kannatinlistan puolelle.  
Nail list to the bottom.



DET 3

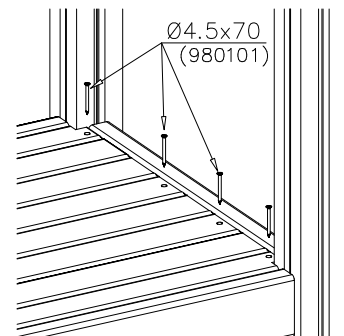

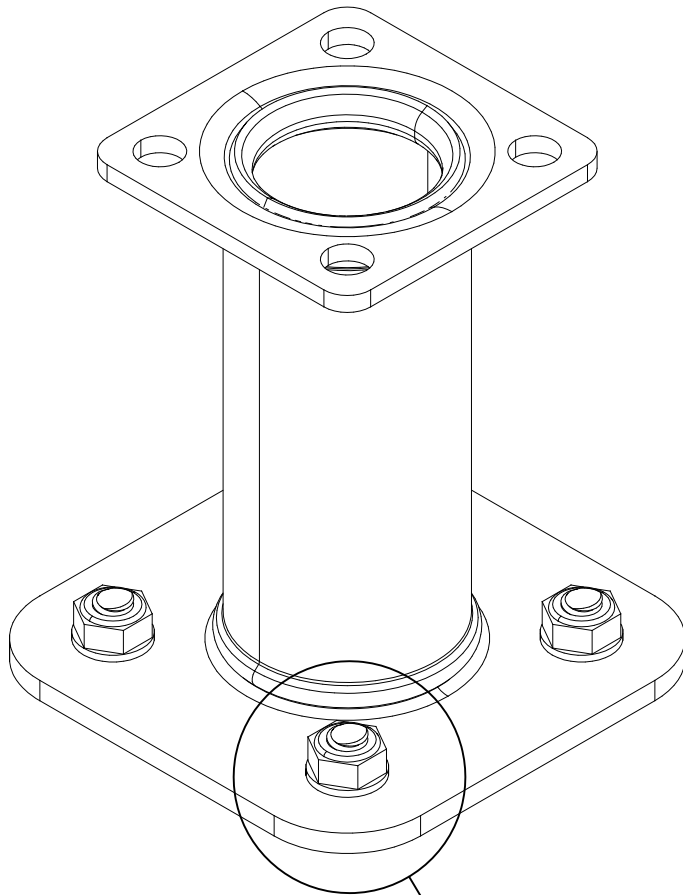

DET 1, 2, 3

① 909531	PCS	① 909513	PCS
	1		1
		60°	
① 909514	PCS	① 902056	PCS
	1		1
		75°	57°
① 902062	PCS		PCS
	1		
		70°	
	PCS		PCS
	PCS		PCS
② 909628	PCS		PCS
	4		
M10x100			

DET 1

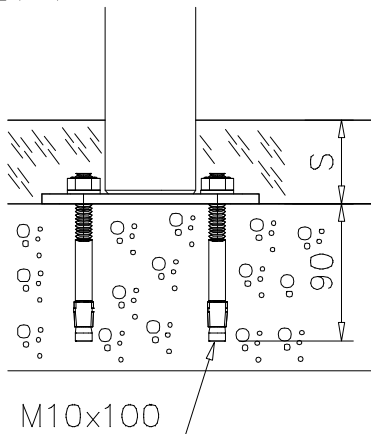

DET 2

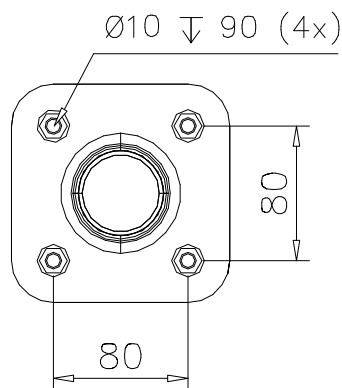

DET 3

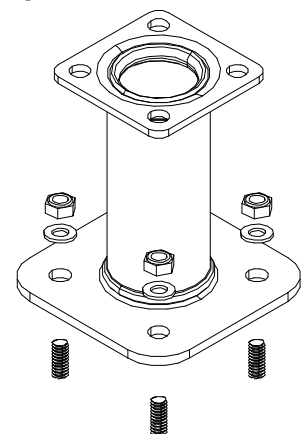

**LAPPSET®**  
**BETON FOUNDATION**

**FOOT**

DATE: 27.10.2015

**1(1)**

② 905104	PCS		PCS
	4		
 M10	PCS		PCS



905104

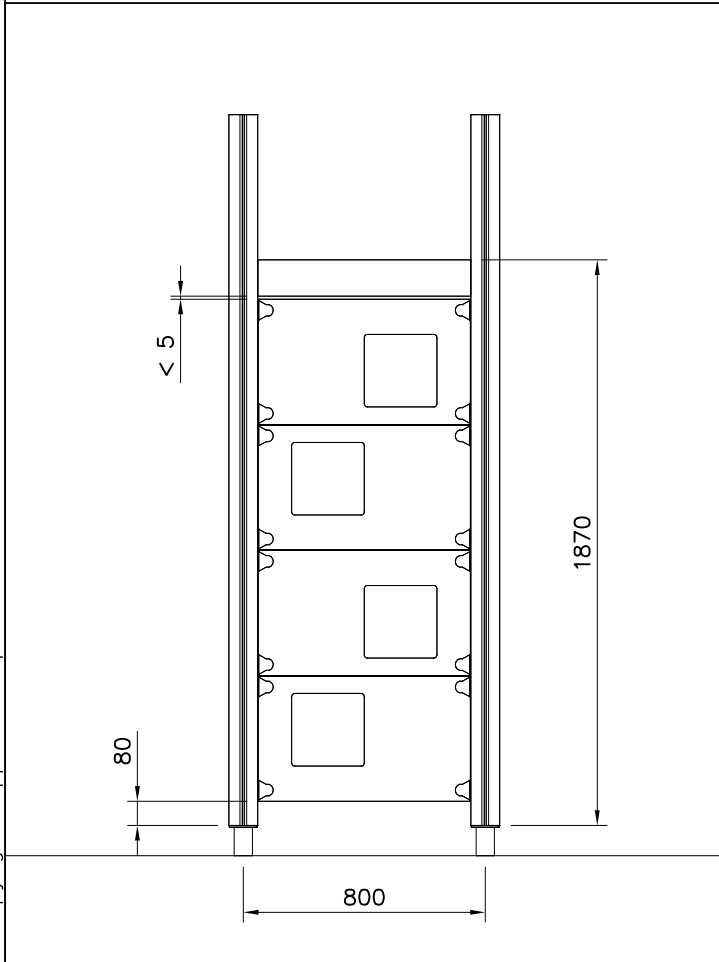
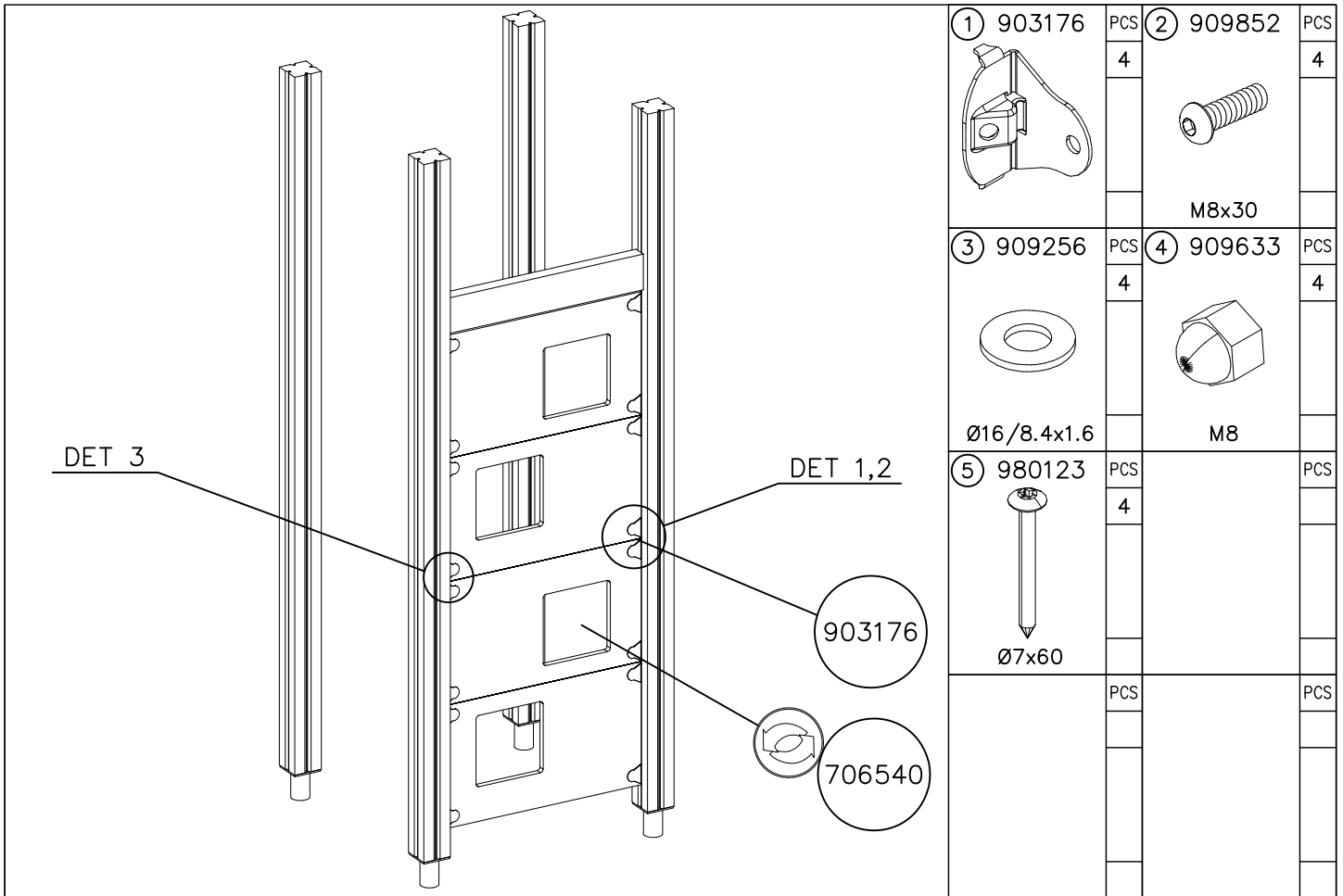

WALL OPTIONS		
706540	706540-701	BLUE
	706540-702	YELLOW
	706540-703	LIME
	706540-704	DARK GRAY
	706540-705	LIGHT GRAY
	706540-706	RED
	706540-707	GREEN
	706540-708	FUXIA
20x702x415		

DET 1

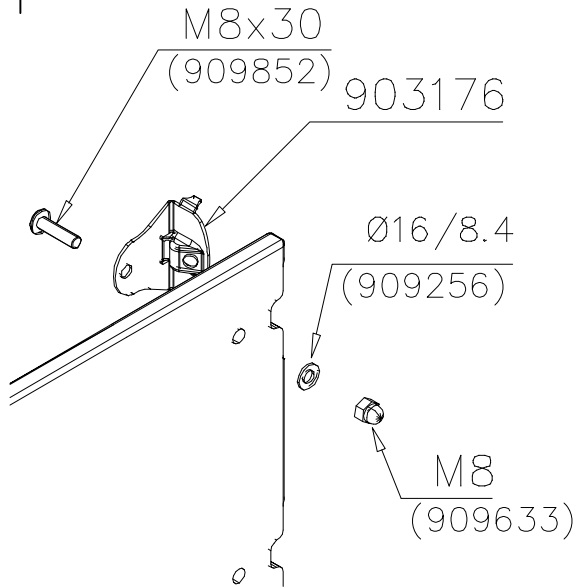

DET 2

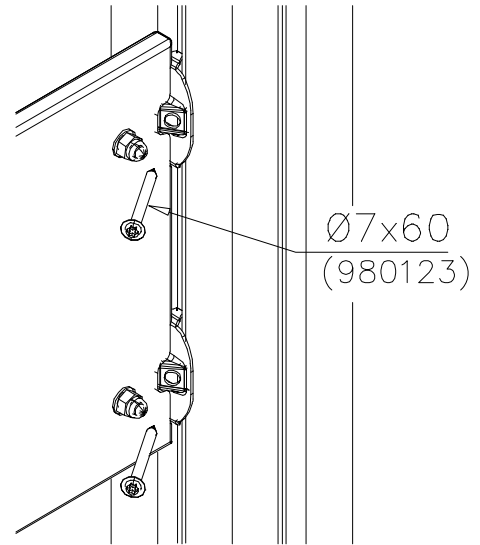

DET 3

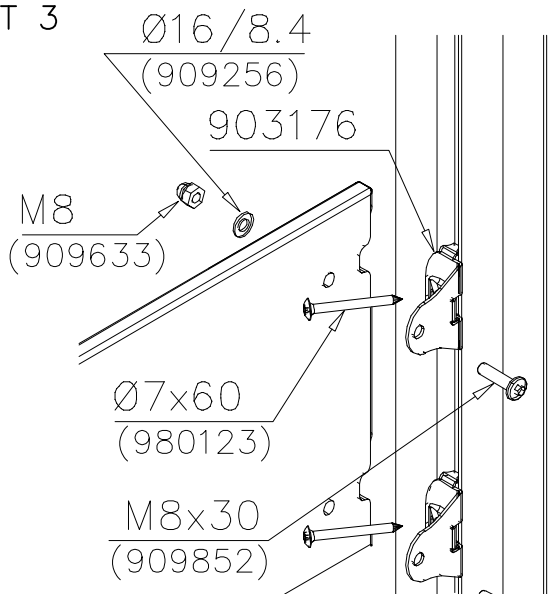

① 706746	PCS	② 909530	PCS
	1		4
45x640x701		55.9x127.5	
③ 900240	PCS	④ 980151	PCS
	4		4
Ø8x70		Ø16/8.4x1.6	
⑤ 905112	PCS		PCS
	4		
Ø22			
	PCS		PCS

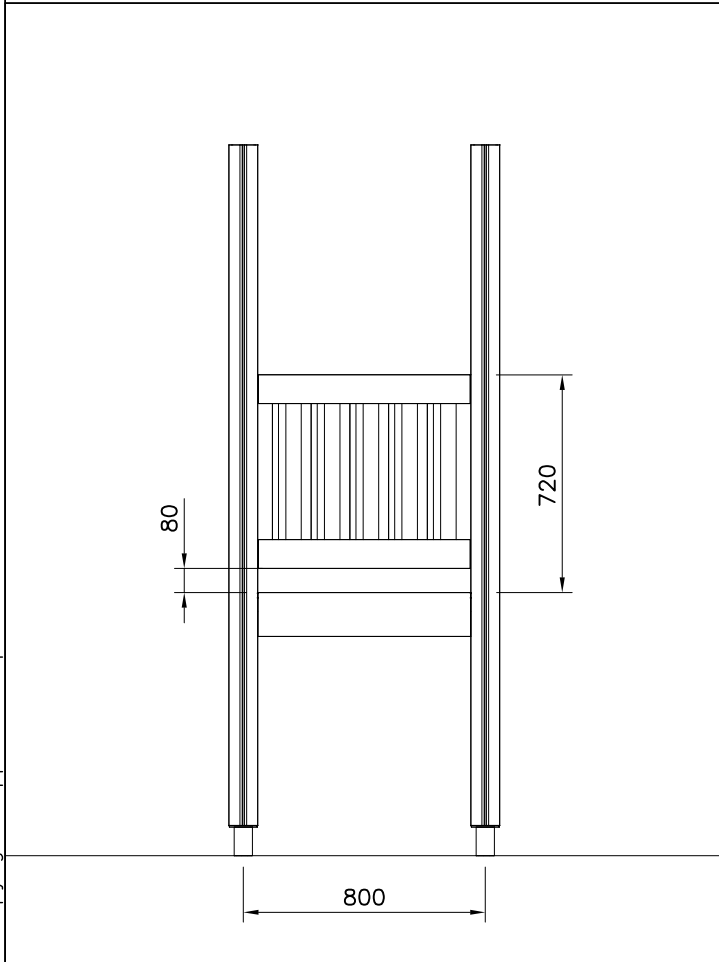

WALL OPTIONS		
 706746 45x640x701	706746-605	DARK GRAY
	706746-606	GRAY
	706746-607	RED
	706746-608	BLUE
	706746-609	GREEN
	706746-610	YELLOW
	706746-611	LIME
	706746-612	FUXIA



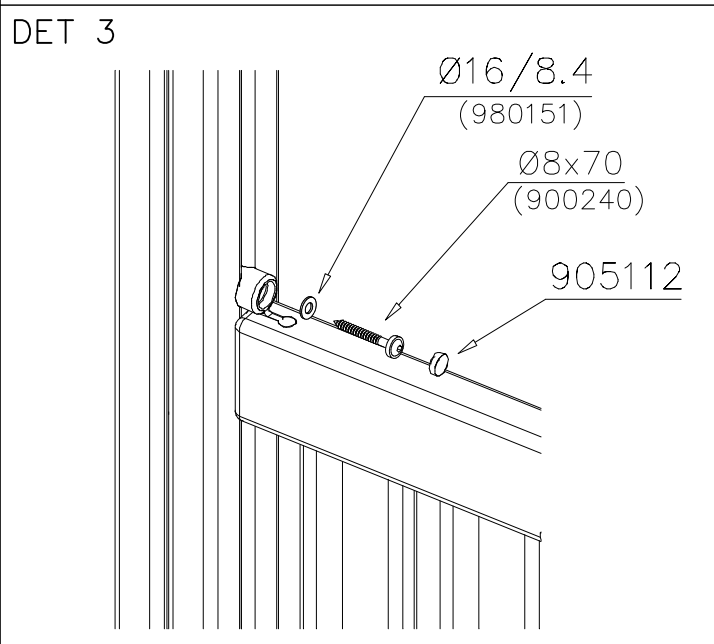
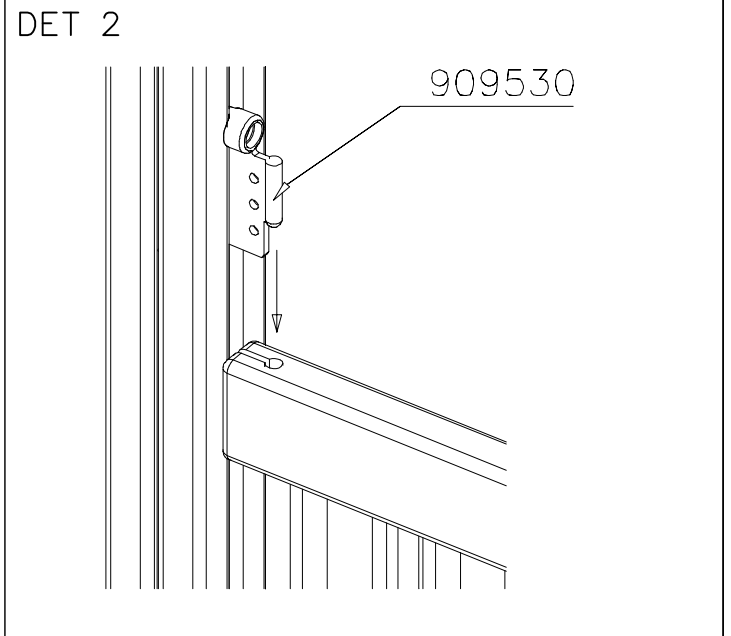
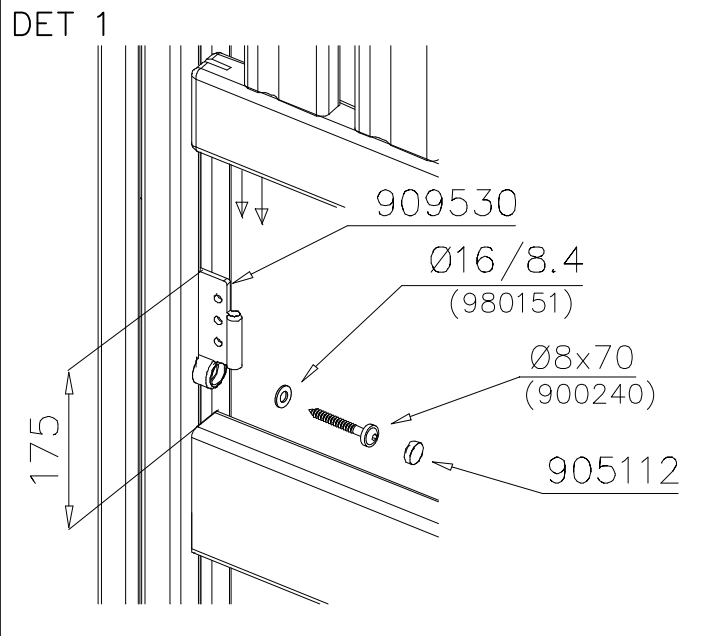

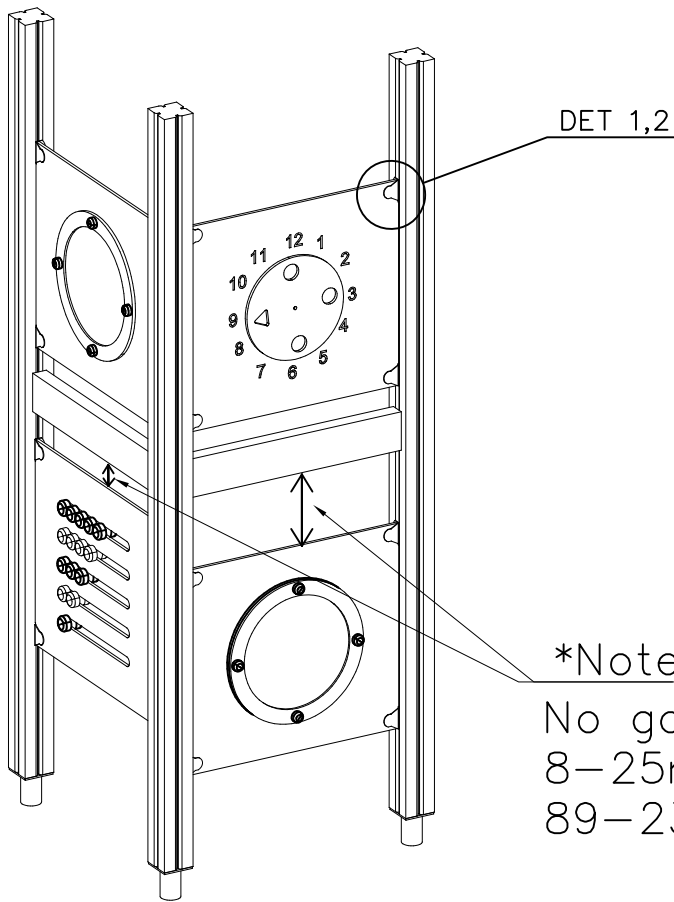

① 903176	PCS	② 909850	PCS
	4		4
		M8x25	
③ 909256	PCS	④ 909633	PCS
	8		4
Ø16/8.4x1.6		M8	
⑤ 980123	PCS		PCS
	4		
Ø7x60			

\*Note:

No gaps between:  
8–25mm  
89–230mm

### COLOR OPTIONS

- 701 BLUE
- 702 YELLOW
- 703 LIME
- 704 DARK GRAY
- 705 LIGHT GRAY
- 706 RED
- 707 GREEN
- 708 FUXIA

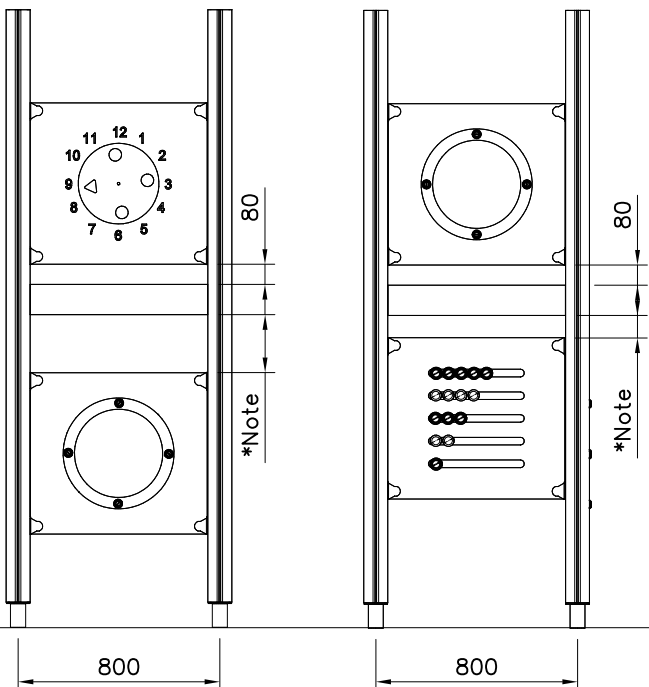

GAME WALL OPTIONS

706766	706772	706308	707453
			
640x702	640x702	640x702	640x702
707209	705705	707433	707386
			
640x702	640x702	640x702	640x702
709403	709358	709405	
			
640x702	640x702	420x702	

DET 1

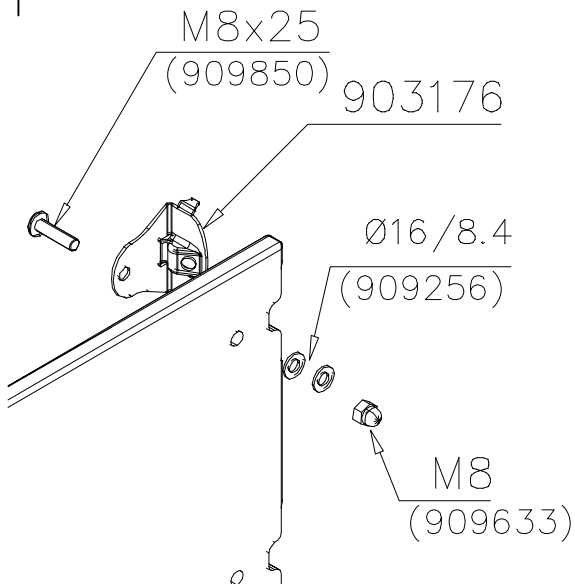

DET 2

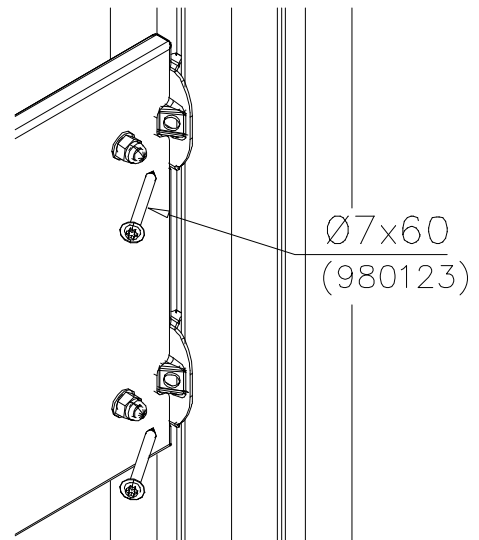

① 706896	PCS	② 903176	PCS
	1		2
15x150x703			
③ 909850	PCS	④ 909256	PCS
	2		2
M8x25		Ø16/8.4x1.6	
⑤ 909633	PCS	⑥ 980123	PCS
	2		2
M8		Ø7x60	
	PCS		PCS

OR

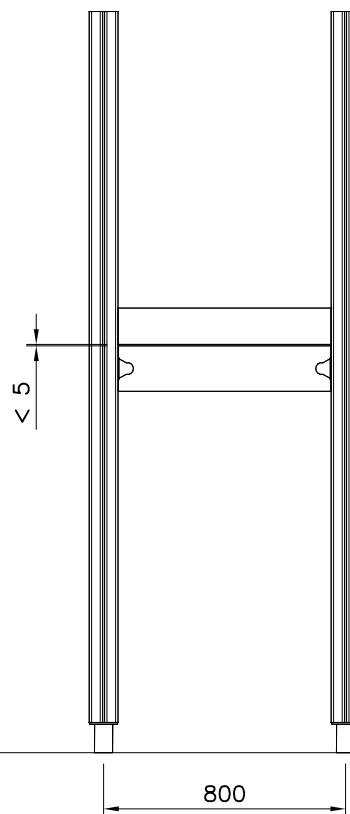
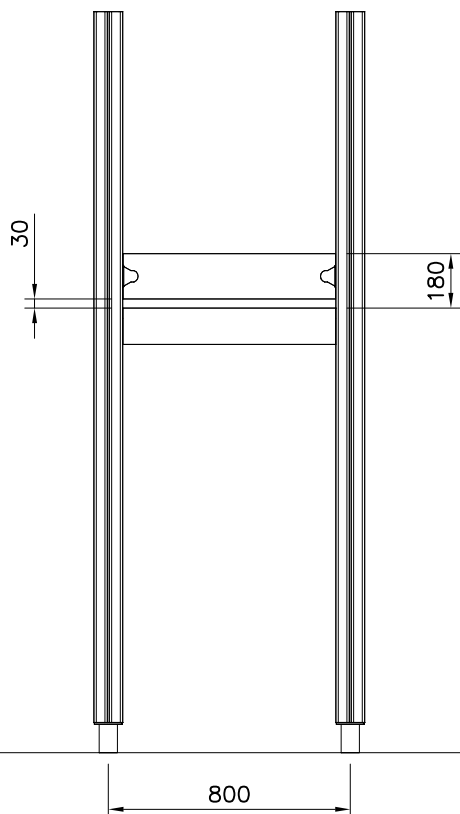

DET 1

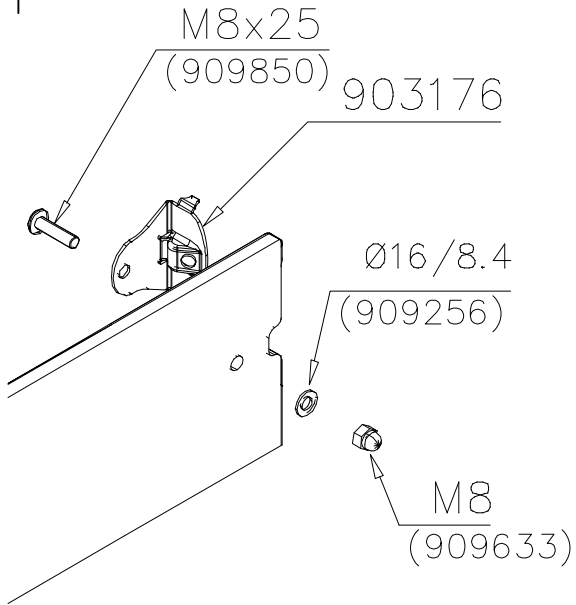

DET 2

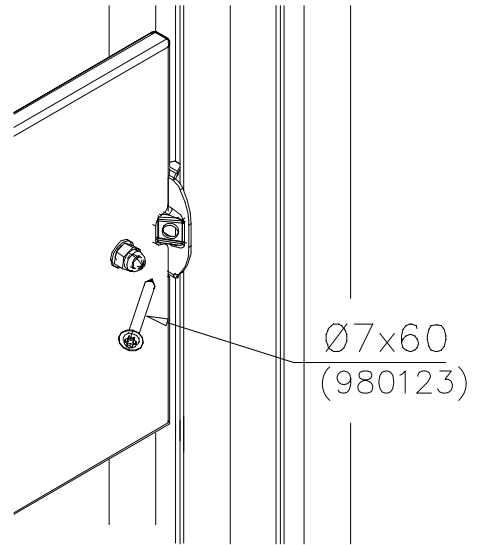

DET 3

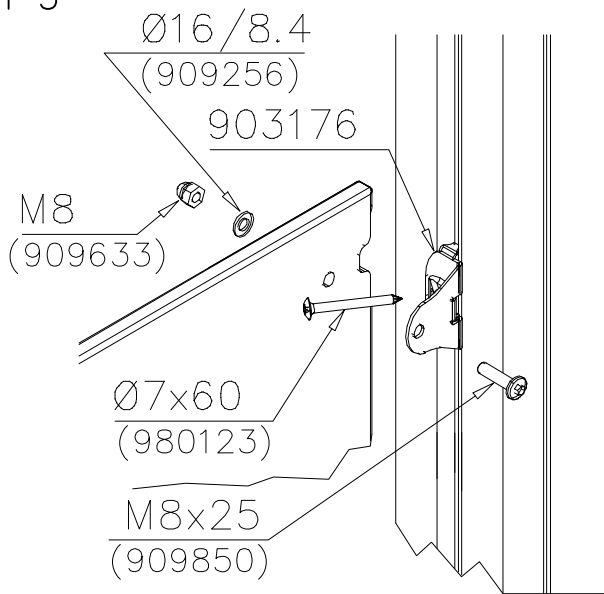

DET 1

DET 2

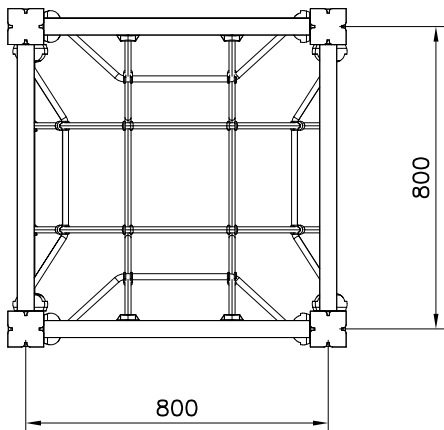
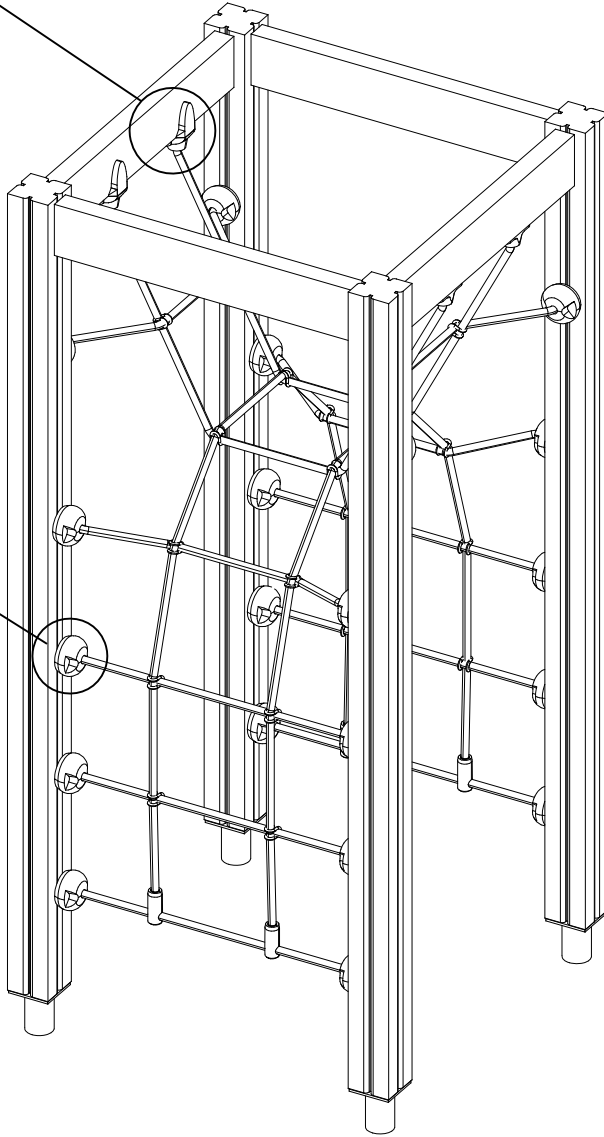

① 707341 1520x705	PCS 1	② 900240 Ø8x70	PCS 40
③ 980123 Ø7x60	PCS 8	④ 980128 Ø7x40	PCS 4
	PCS		PCS
	PCS		PCS
	PCS		PCS
	PCS		PCS

NET OPTIONS

707341

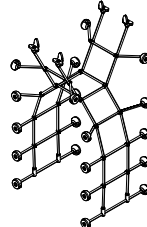

1520x705

- 707341-301 BLUE
- 707341-302 RED
- 707341-303 BEIGE
- 707341-304 GREY
- 707341-305 BLACK

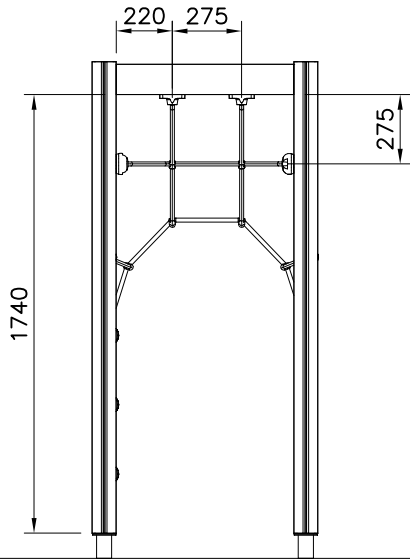

DET 1

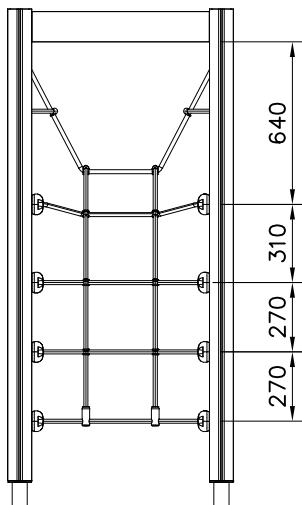
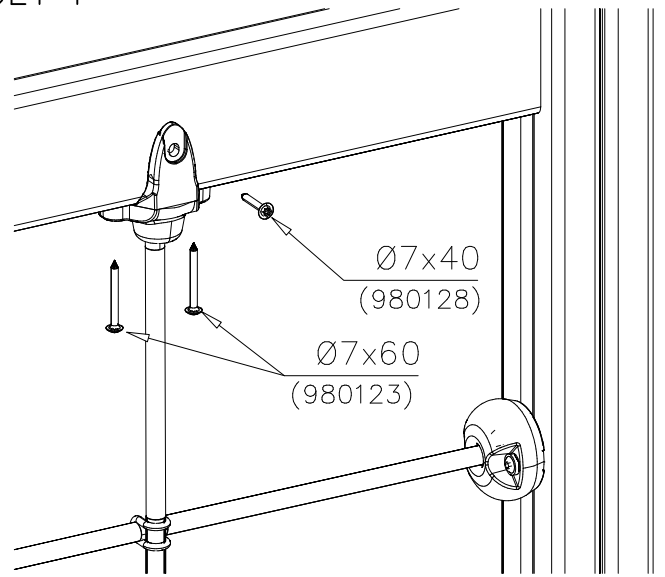

DET 2

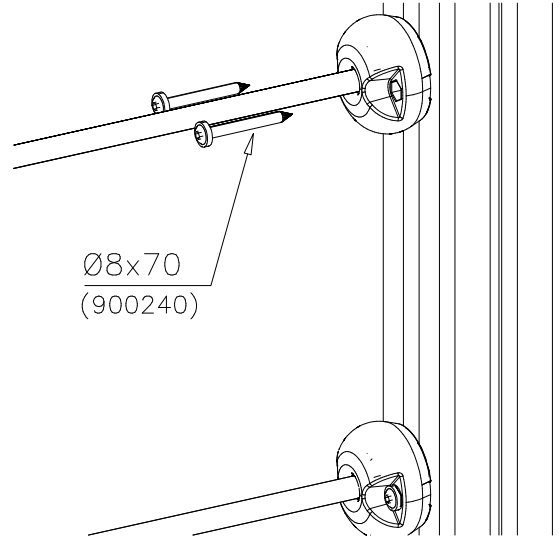

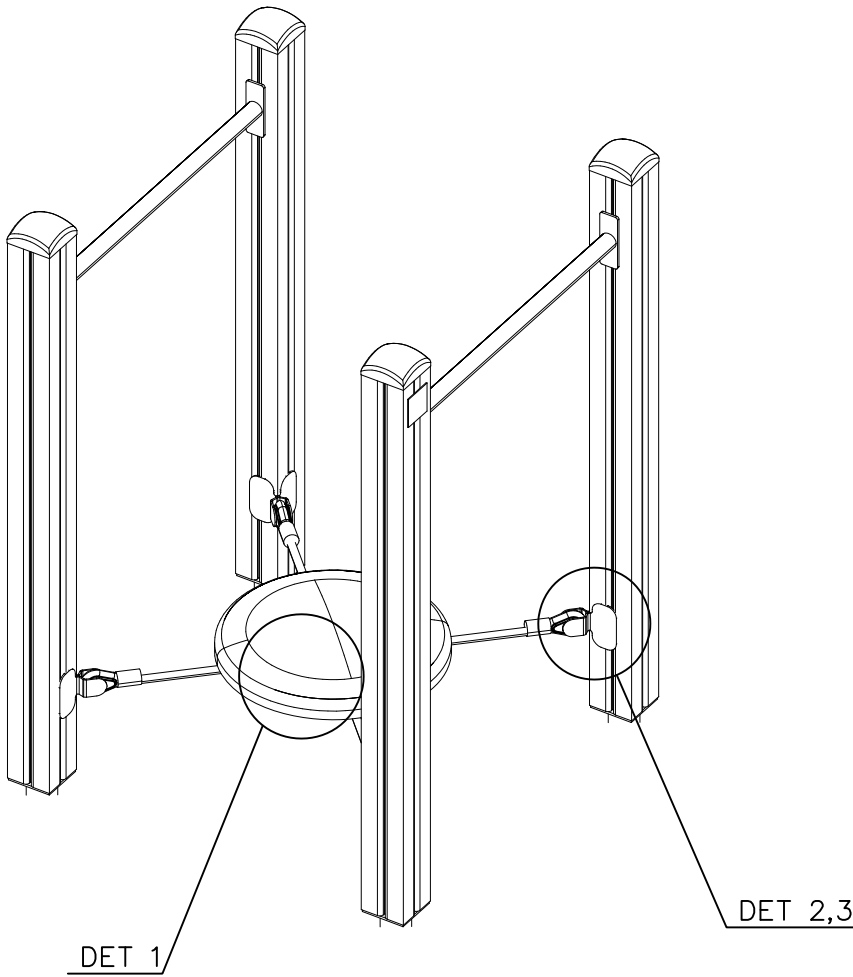

①	929561	PCS	②	909568	PCS
		8			4
				M8x55	
③	901104	PCS	④	900240	PCS
		4			16
	M8x80			Ø8x70	
⑤	905083	PCS	⑥	909256	PCS
		8			28
	Ø32			Ø16/8.4	
⑦	980152	PCS	⑧	980160	PCS
		4			4
	Ø24/8.4			M8	
⑨	905112	PCS	⑩	909633	PCS
		8			4
	Ø22			M8	
		PCS			PCS
		PCS			PCS
		PCS			PCS

DET 1

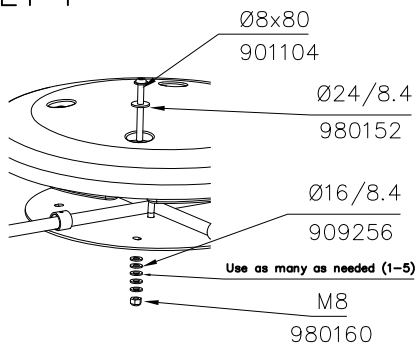

DET 3

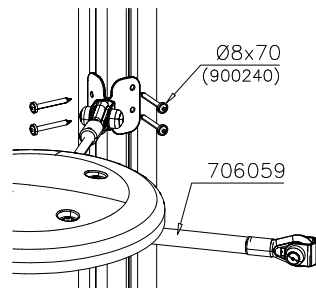

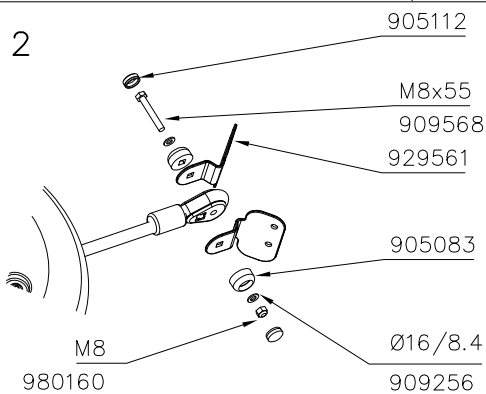

DET 2



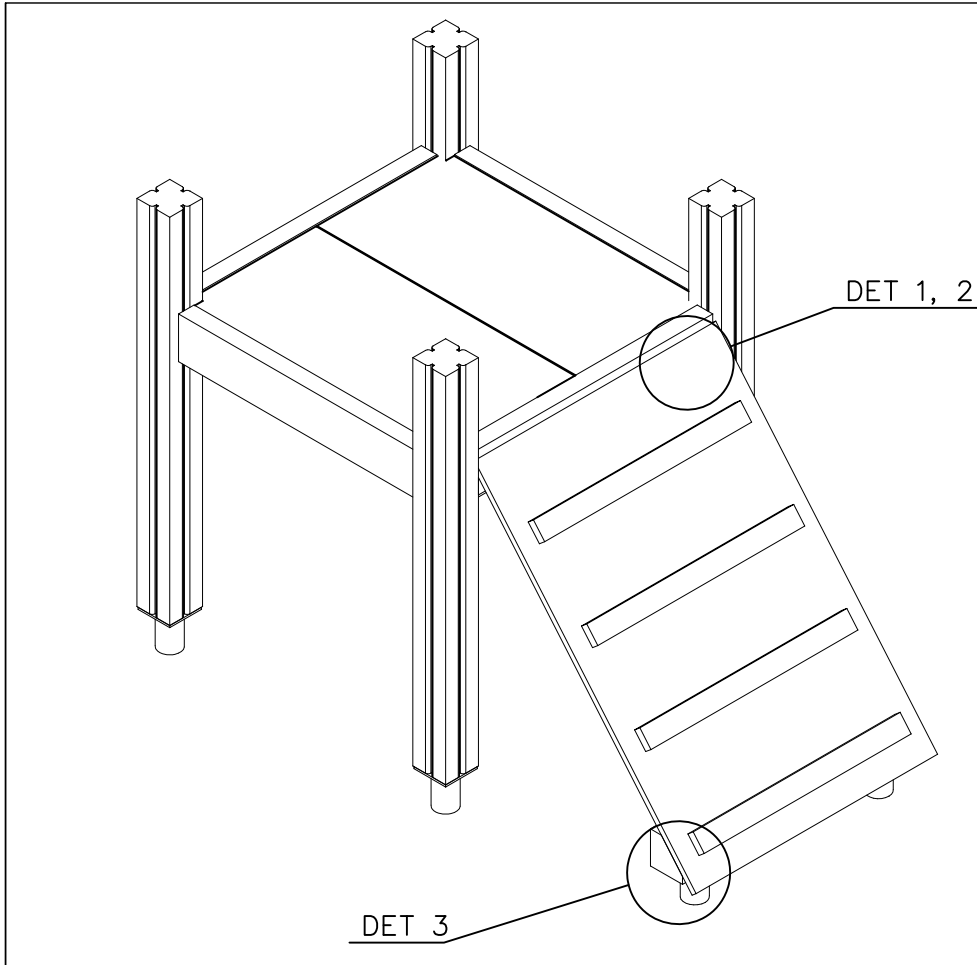

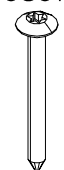
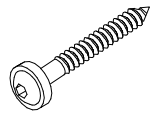

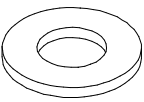
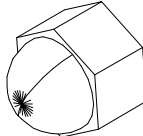
①	980128	PCS	②	900240	PCS
		8			4
	Ø7x40			Ø8x70	
③	909852	PCS	④	909256	PCS
		3			7
	M8x30			Ø16/8.4x1.6	
⑤	909633	PCS			PCS
		3			
	M8				
		PCS			PCS

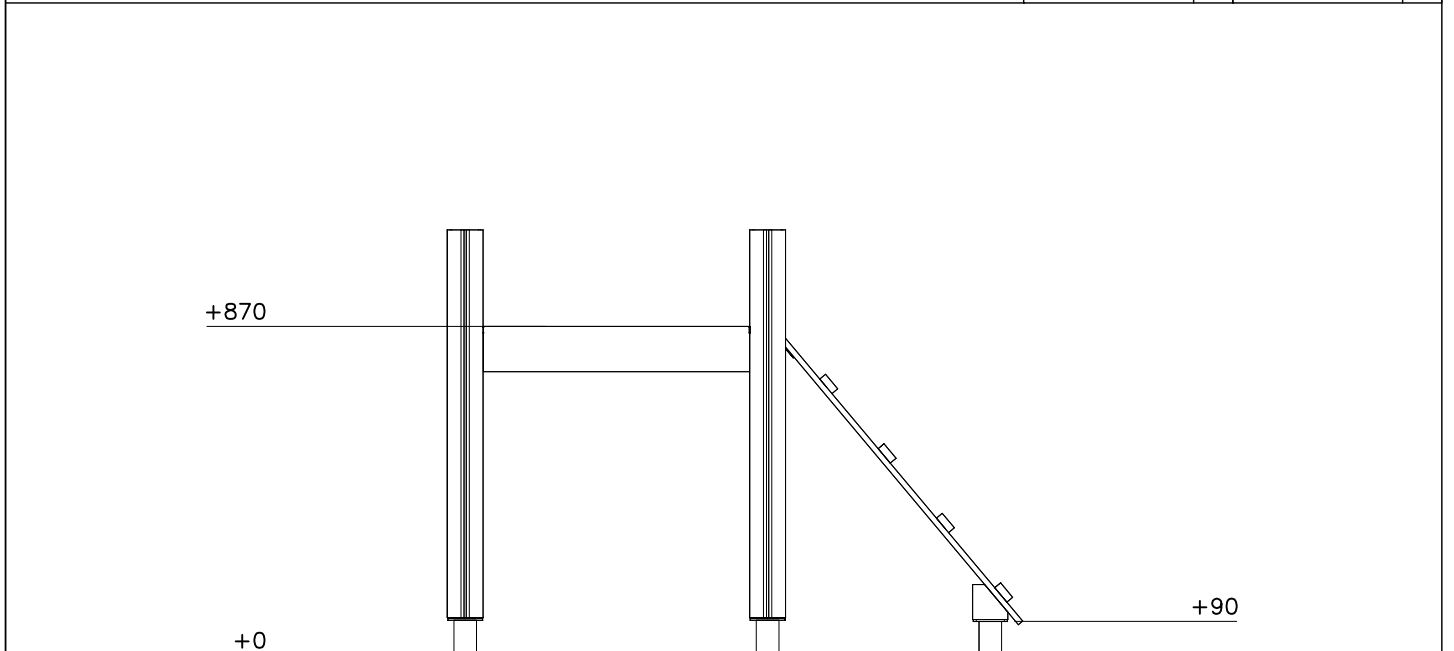

### CLIMB OPTIONS

707418

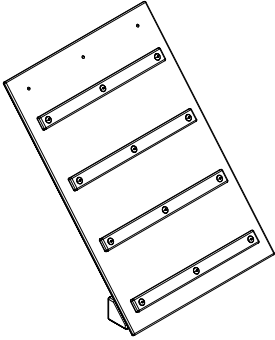

700x1000

707418-701	BLUE
707418-702	YELLOW
707418-703	LIME
707418-704	DARK GREY
707418-705	GREY
707418-706	RED
707418-707	GREEN
707418-708	FUCHSIA

DET 1

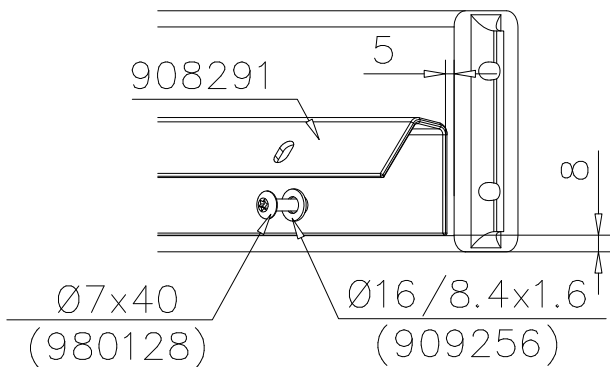

DET 2

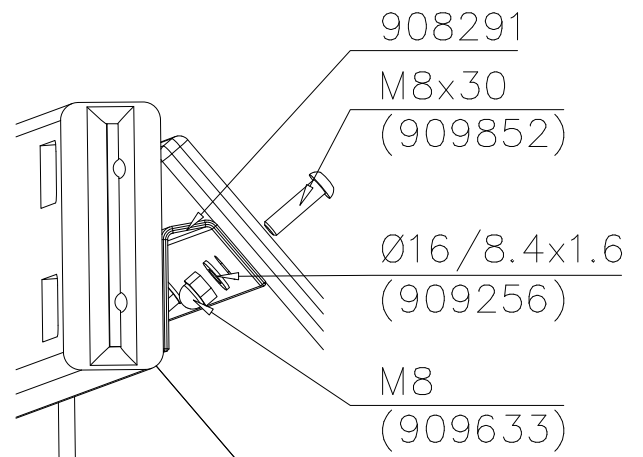

DET 3

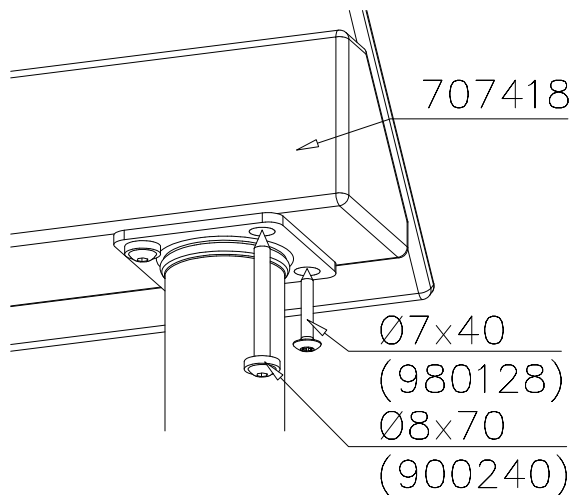



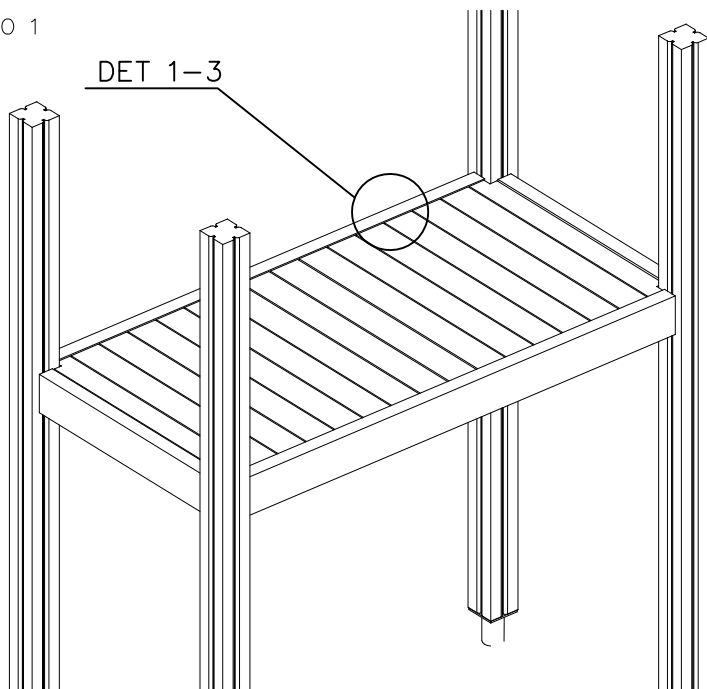

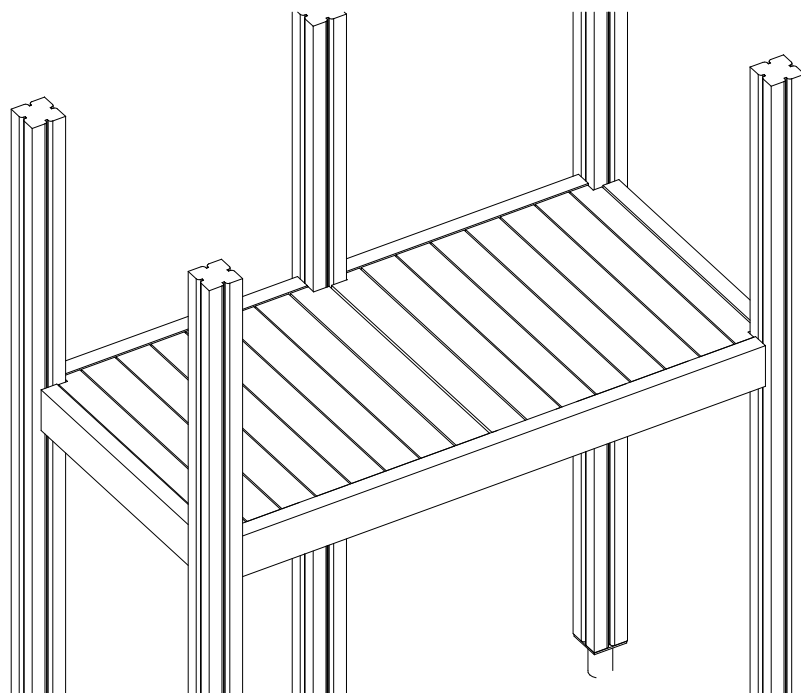

OPTIO 1

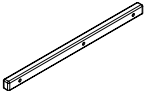

OPTIO 2



① 900240	PCS	② 980101	PCS
	12		16
Ø8x70		Ø4.5x70	
	PCS		PCS
	PCS		PCS
○ 706443	PCS	○ 707435	PCS
			
32x45x702		750x770	
○ 707436	PCS	○ 707437	PCS
			
750x770		32x45x1502	
	PCS	○ 707441	PCS
			
		750x770	

DET 1

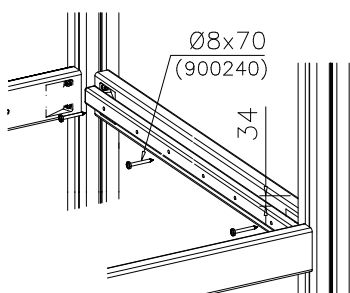

DET 2

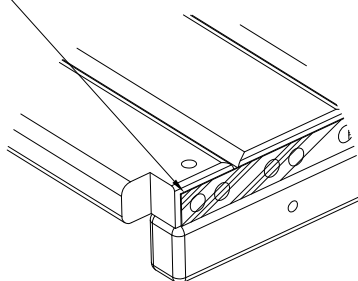

Naulanauha kannatinlistan puolelle.  
Nail list to the bottom.

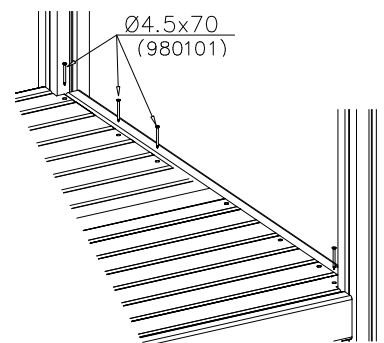

DET 3

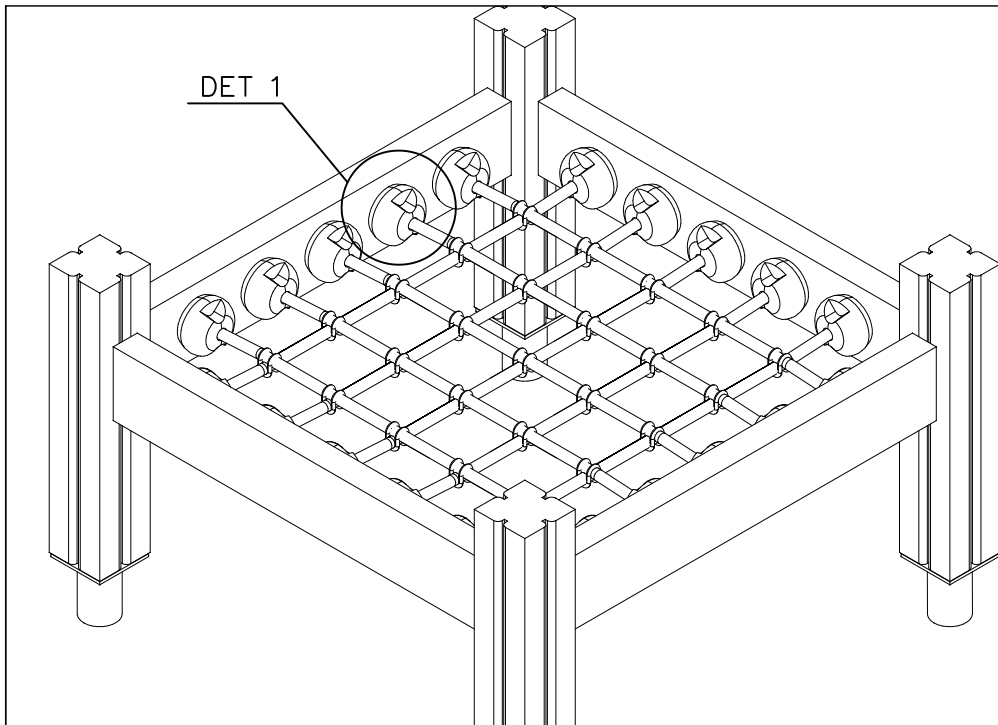

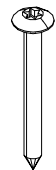

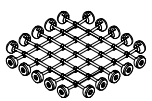

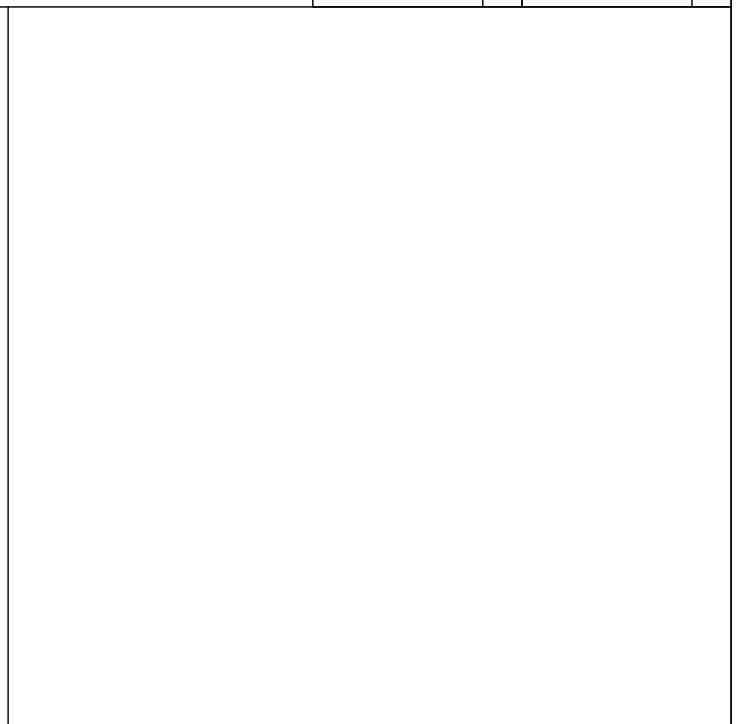
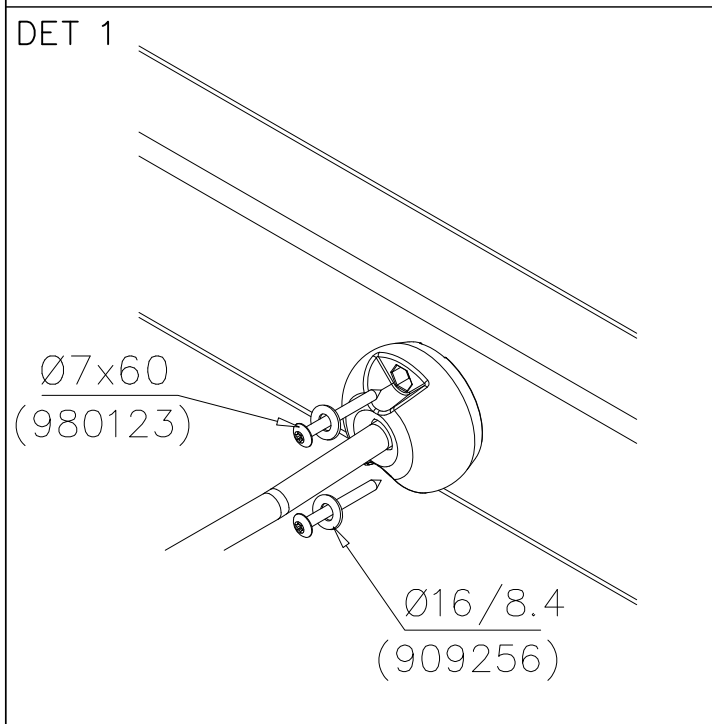
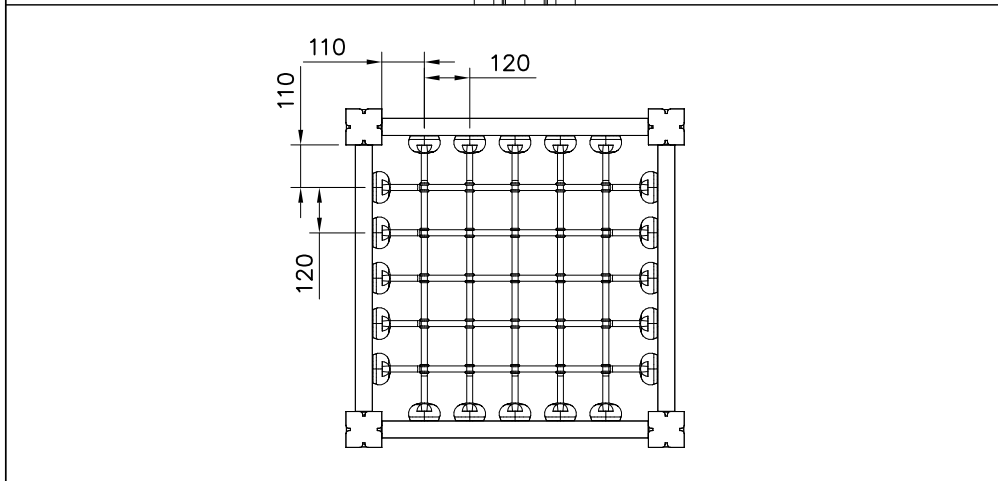
① 980123	PCS	② 909256	PCS
	40		40
Ø7x60		Ø16/8.4	
	PCS		PCS
	PCS	③ 707590	PCS
			
		755x755	
	PCS		PCS
	PCS		PCS

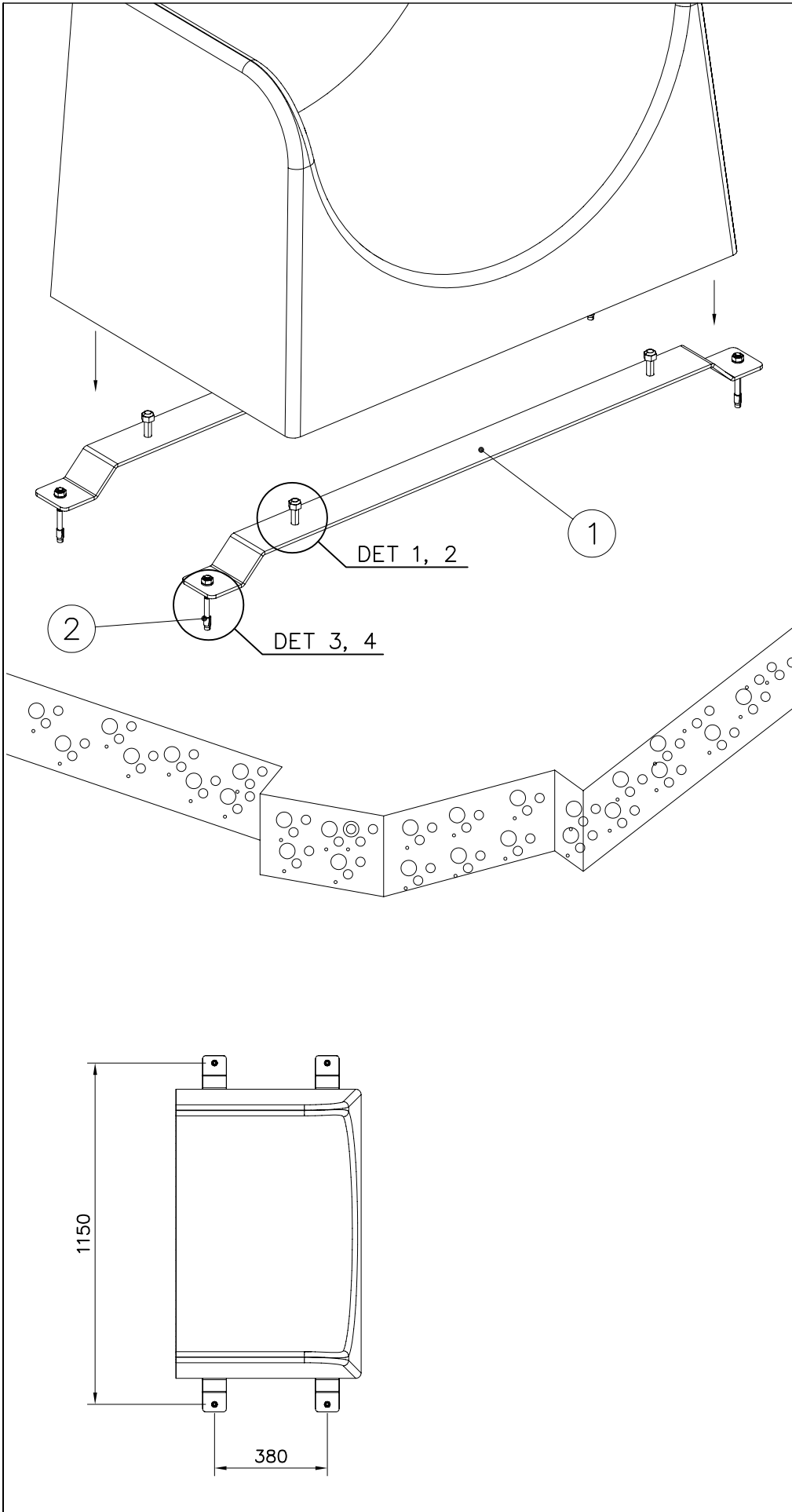

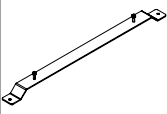

① 905858	PCS	② 909628	PCS
	2		4
1200x80x90		M10x100	
	PCS		PCS
	PCS		PCS
	PCS		PCS
	PCS		PCS
	PCS		PCS
	PCS		PCS

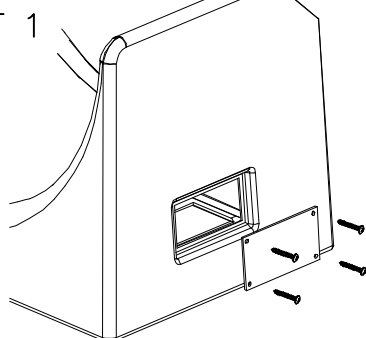
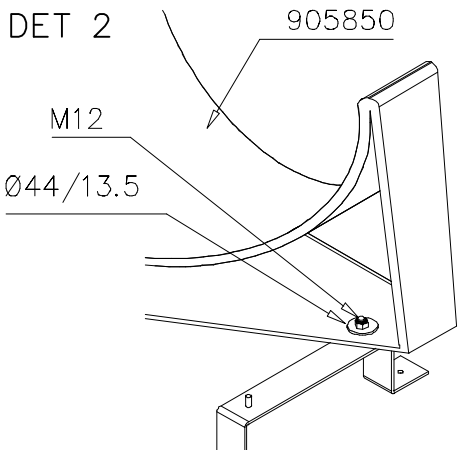
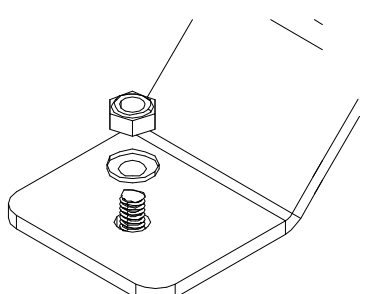
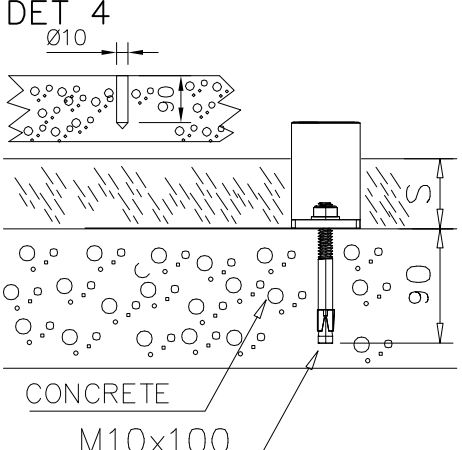
<p>DET 1</p>  <p>Access- and maintenance panel.          Asennus- ja huolto luukku.</p>	<p>DET 2</p>  <p>905850</p> <p>M12</p> <p>Ø44/13.5</p>	<p>DET 3</p> 
<p>DET 4</p>  <p>Ø10</p> <p>90</p> <p>S</p> <p>90</p> <p>CONCRETE</p> <p>M10x100</p>		







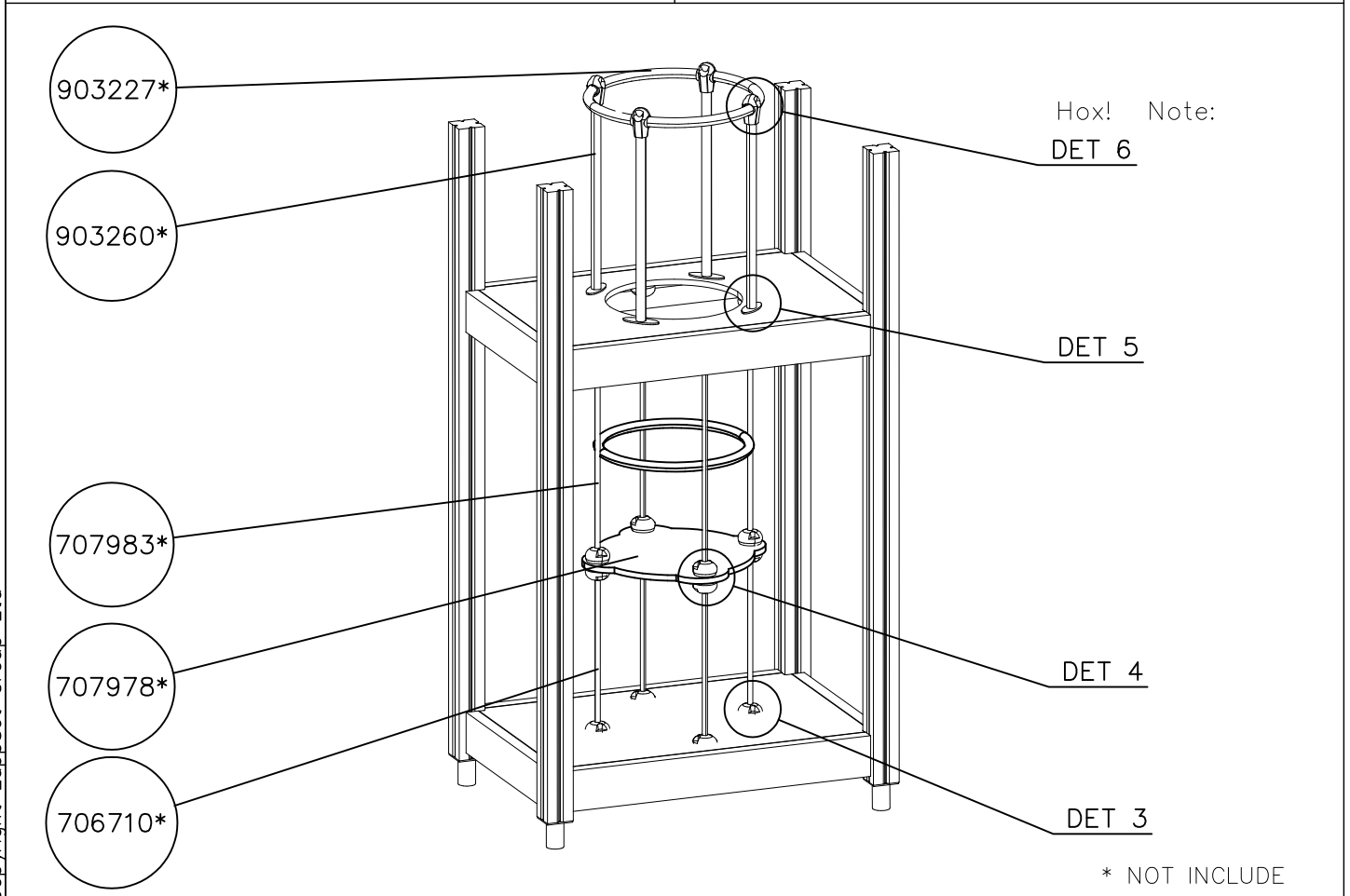
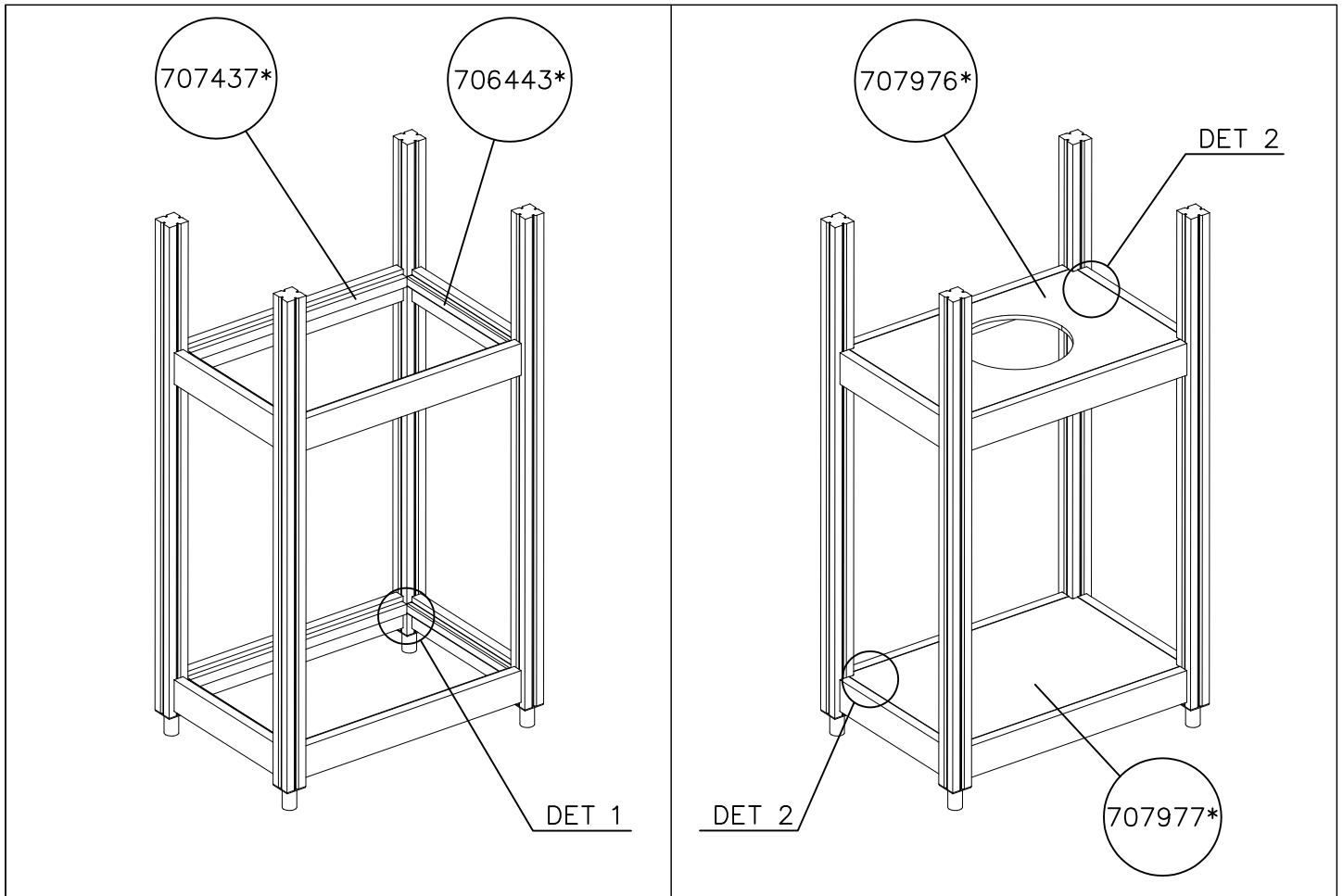



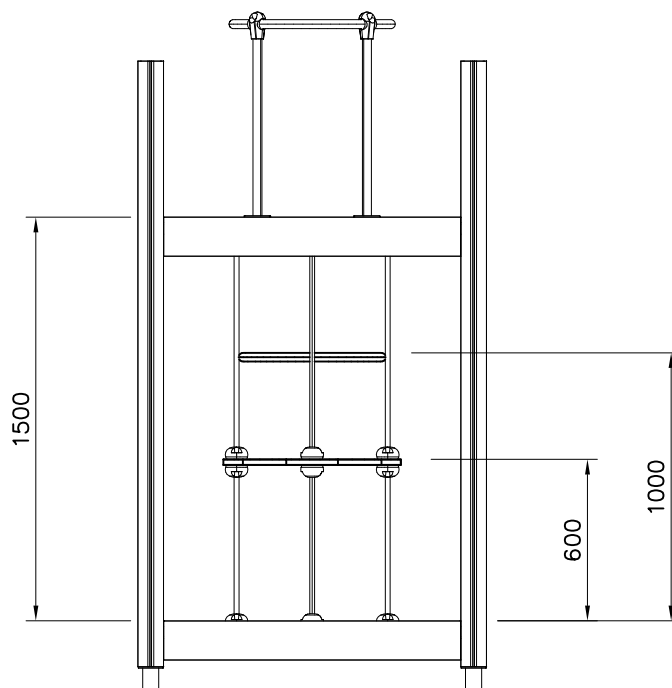
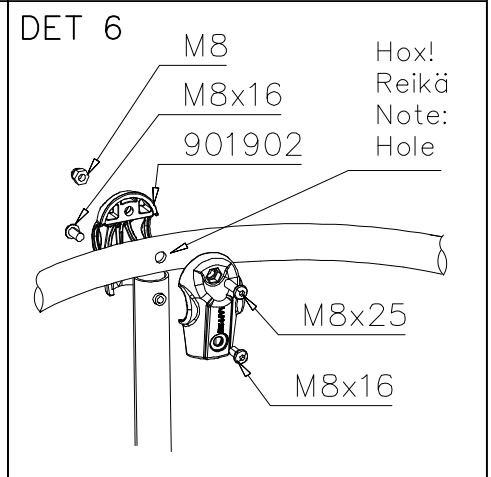
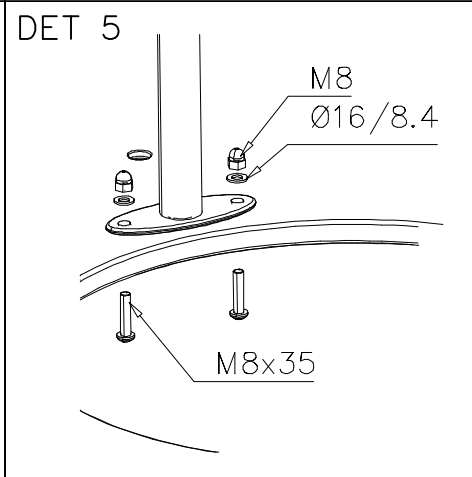
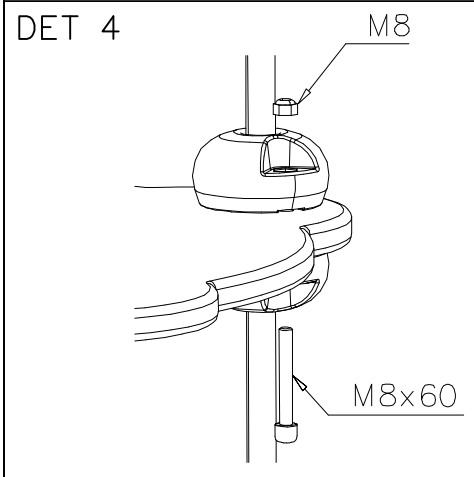
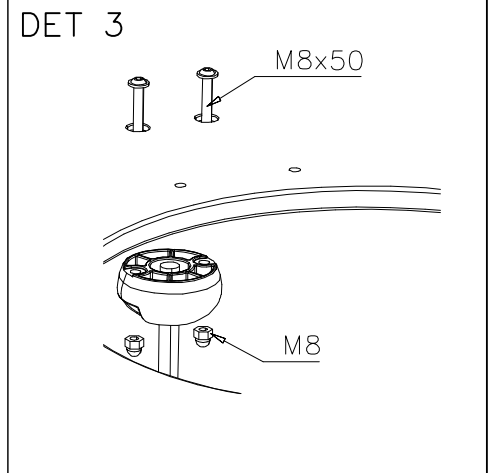
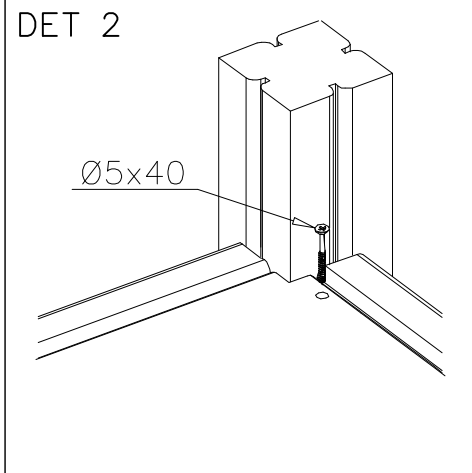
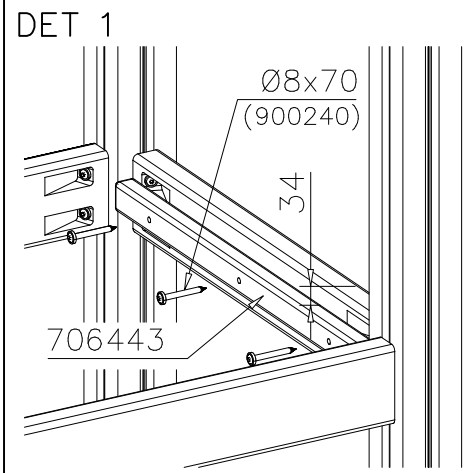

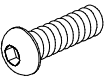
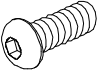
① 900240	PCS	② 900727	PCS
	1		1
Ø8x70		M10x80	
	PCS		PCS
③ 907688	PCS	③ 907701	PCS
	1		1
765		545	
	PCS		PCS
	PCS		PCS
	PCS		PCS
	PCS		PCS

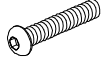
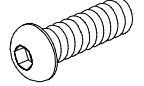
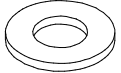
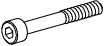
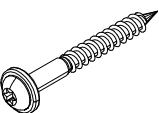
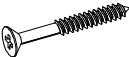

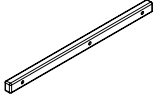

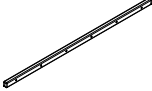
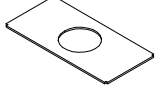

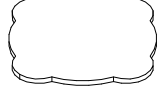
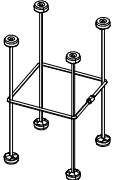

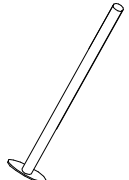

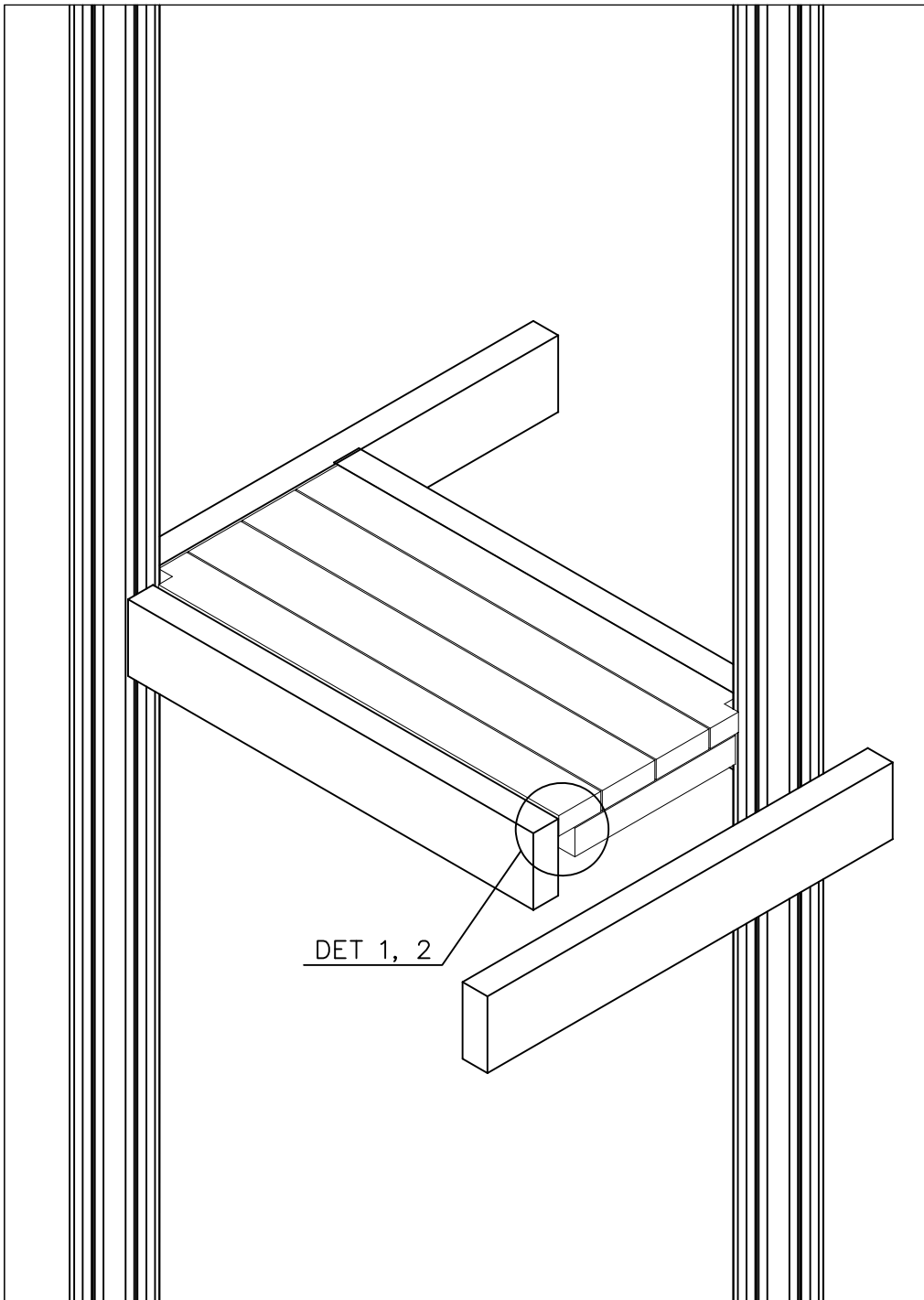
909850	PCS 4	900342	PCS 8	909633	PCS 36	909855	PCS 8	900498	PCS 16	909256	PCS 8
											
M8x25		M8x16		M8		M8x35		M8x50		Ø16/8.4x1.6	
909205	PCS 8	900240	PCS 36	980102	PCS 24	901902	PCS 8		PCS		PCS
											
M8x60		Ø8x70		Ø5x40		30.7x60.9x100					
	PCS		PCS		PCS		PCS		PCS		PCS
	PCS		PCS		PCS		PCS		PCS		PCS
	PCS		PCS		PCS		PCS		PCS		PCS
NOT INCLUDE											
706443	PCS 4	706710	PCS 4	707437	PCS 4	707976	PCS 1	707977	PCS 1	707978	PCS 1
											
32x45x702		Ø16x618		32x45x1502		15x750x1550		15x750x1550		15x550x550	
707983	PCS 1	903227	PCS 1	903260	PCS 4		PCS		PCS		PCS
											
396x840		Ø618x34		50x130x704							



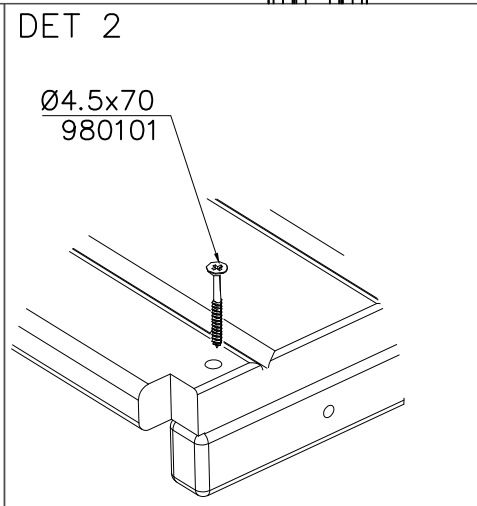
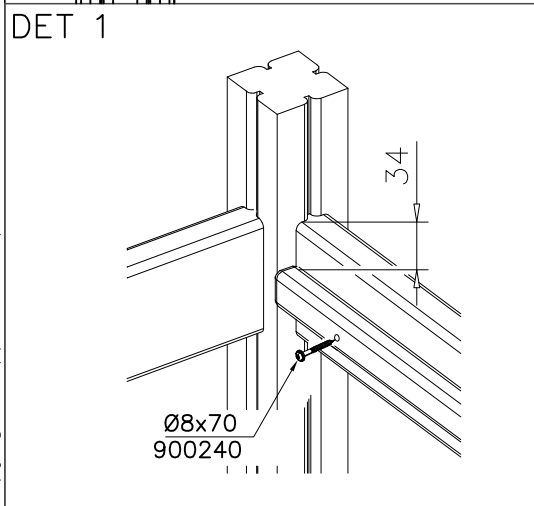

DET 1, 2

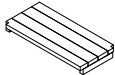
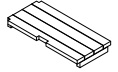
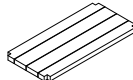
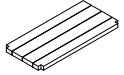

① 900240	PCS	② 980101	PCS
	4		4
Ø8x70		Ø4.5x70	
	PCS		PCS
	PCS		PCS

OPTIONS

○ 709859	PCS	○ 709861	PCS
	1		1
32x350x748		32x350x748	
○ 709867	PCS	○ 709868	PCS
	1		1
32x350x748		32x350x748	
○ 709858	PCS		PCS
	2		
32x45x290			
	PCS		PCS

**Tuotekyltti tulee tuotteen mukana yhdellä seuraavista tavoista:****1) Metallinen tuotekyltti ja kiinnitysruuvit**

- Kiinnitä tuotekyltti ruuveilla tolppaan noin 2 metrin korkeuteen kuvan 1 mukaisesti.

**2) Tuotekylttitarra**

- Puhdista maalattu metalli- tai vaneripinta pölystä ja kosteudesta. Liimaa tarra kuvan 2 mukaisesti.
- Huom. Älä kiinnitä tarraa karheapintaiseen laminaattiin tai maalattuun puuhun.

**Vår produktmärkning levereras på ett av följande sätt:****1) Produktskylt i metall**

- Fäst skylten med de medföljande skruvarna

**2) Självhäftande produktetikett**

- Rengör den pulverlackerade metallytan eller laminatyten så att den blir fri från smuts och fukt. Fäst etiketten enligt fig. 2.
- Obs! Fäst ej etiketten på detaljer med skrovlig yta eller på målat trä.

**Product label is delivered by one of following ways:****1) Metal product label and screws**

- Fasten the label with screws.

**2) Label sticker**

- Clean the painted metal or plywood surface from dirt and moisture. Fasten the sticker as shown in the figure 2.
- Note. Do not attach the sticker to rough surfaced laminate or painted wood.

**La plaque d'informations produit est livrée sous l'une de ces 3 formes :****1) Plaque métallique et vis**

- Fixez la plaque à l'aide des vis.

**2) Etiquette autocollante**

- Avant de coller l'étiquette, nettoyez le composant métallique peint ou la plaque de contreplaqué, de toute saleté. La surface doit être sèche (voir image 2).
- Attention, ne pas coller l'étiquette sur une surface lamellé-collée irrégulière ou sur du bois peint.

**Die Auslieferung des Produktaufklebers erfolgt auf eine dieser Arten:****1) Produkt-Schild aus Metall incl. Schrauben**

- Die Befestigung des Schildes erfolgt mittels der Schrauben.

**2) Aufkleber**

- Entfernen Sie zunächst Schmutz und Feuchtigkeit vom lackierten Metall bzw. von der Holzoberfläche und bringen Sie den Aufkleber wie im Bild oben rechts beschrieben auf den gesäuberten Untergrund auf.
- Beachten Sie: Bringen Sie den Aufkleber nicht auf raues laminiertes oder lackiertes Holz an.

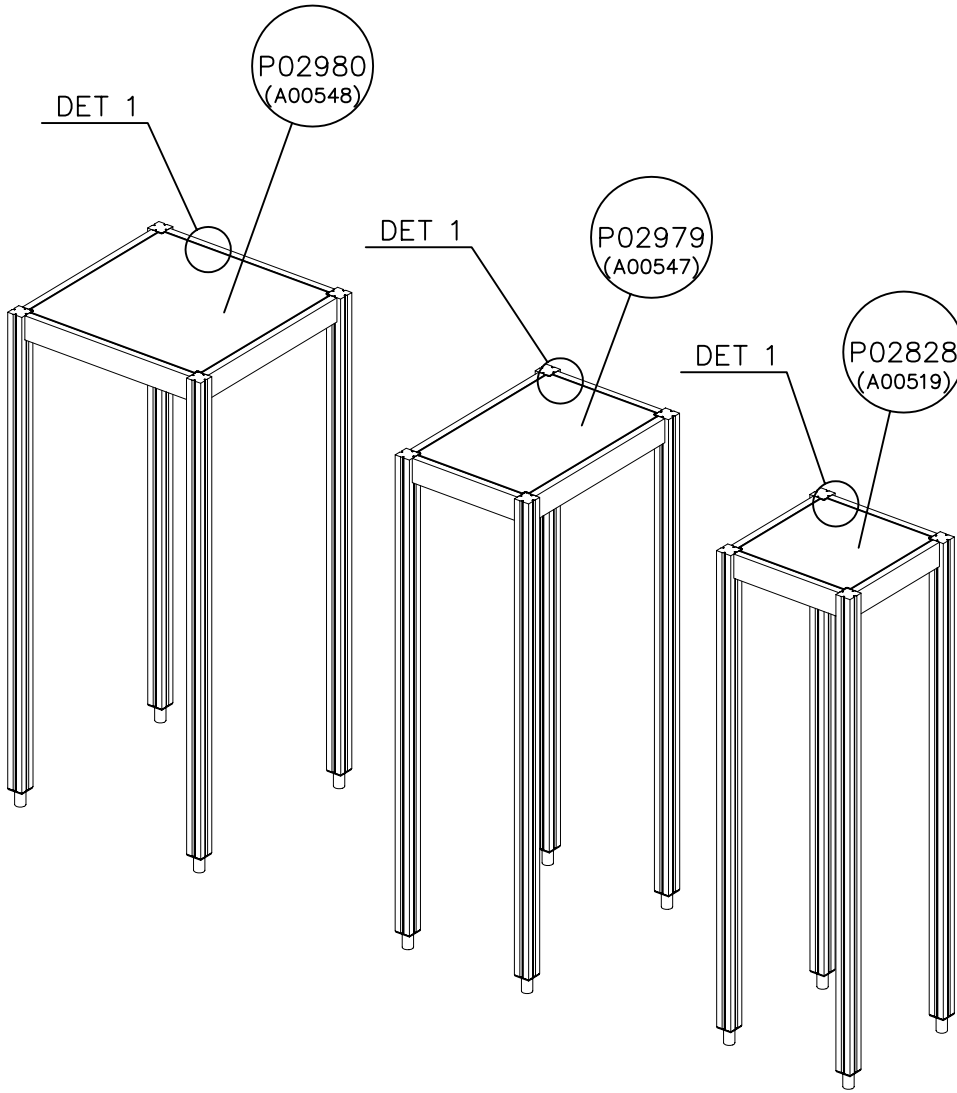



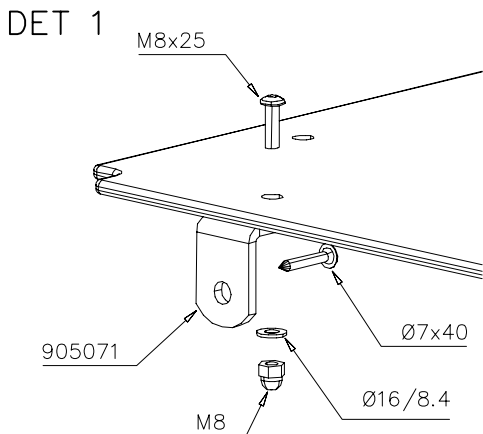

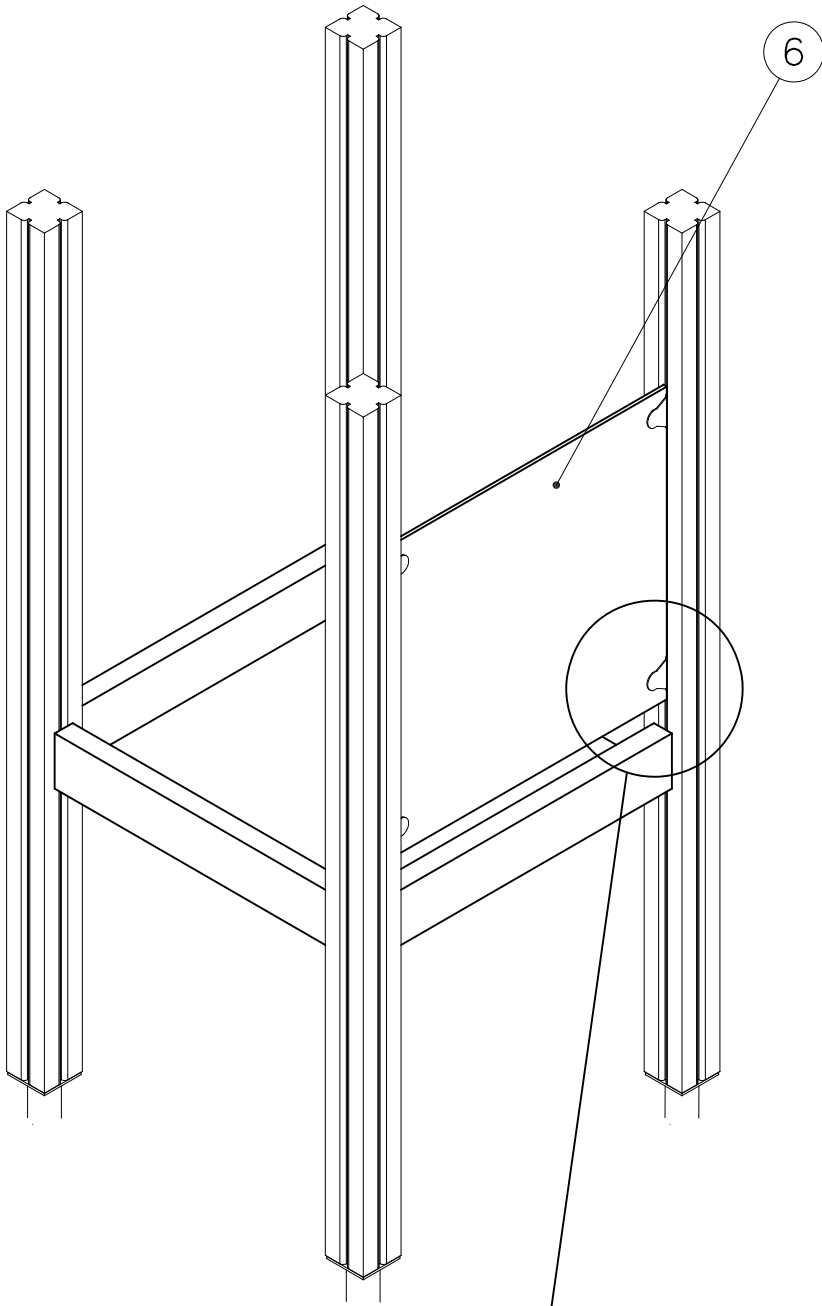
① A00519	PCS	② A00547	PCS
	1		1
③ A00548	PCS		PCS
	1		
	PCS		PCS
	PCS		PCS
	PCS		PCS
	PCS		PCS
	PCS		PCS
	PCS		PCS



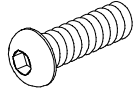
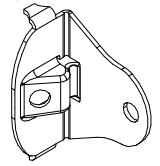
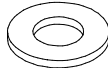

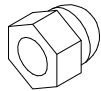
DET 1,2

① 905827	PCS	② 903176	PCS
	4		4
M8x20			
③ 909256	PCS	④ 980123	PCS
	4		4
Ø16/8.4		Ø7x60	
⑤ 909633	PCS	⑥ P05280	PCS
	4		1
M8		12x680x700	
	PCS		PCS
	PCS		PCS
	PCS		PCS
	PCS		PCS

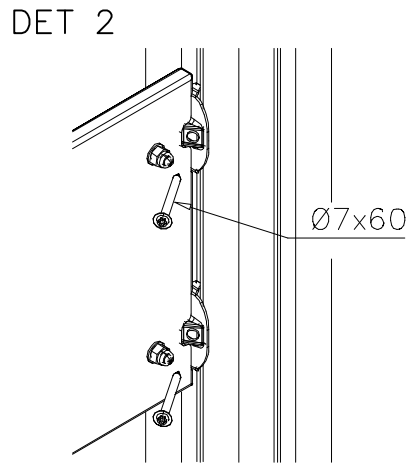
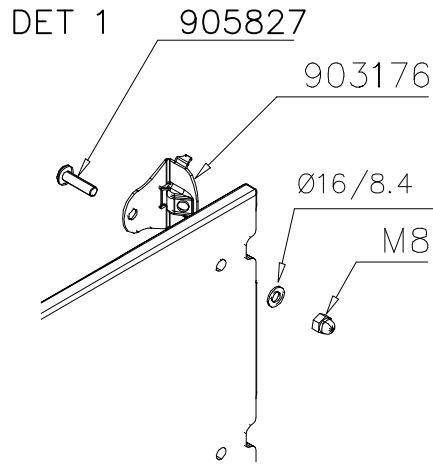

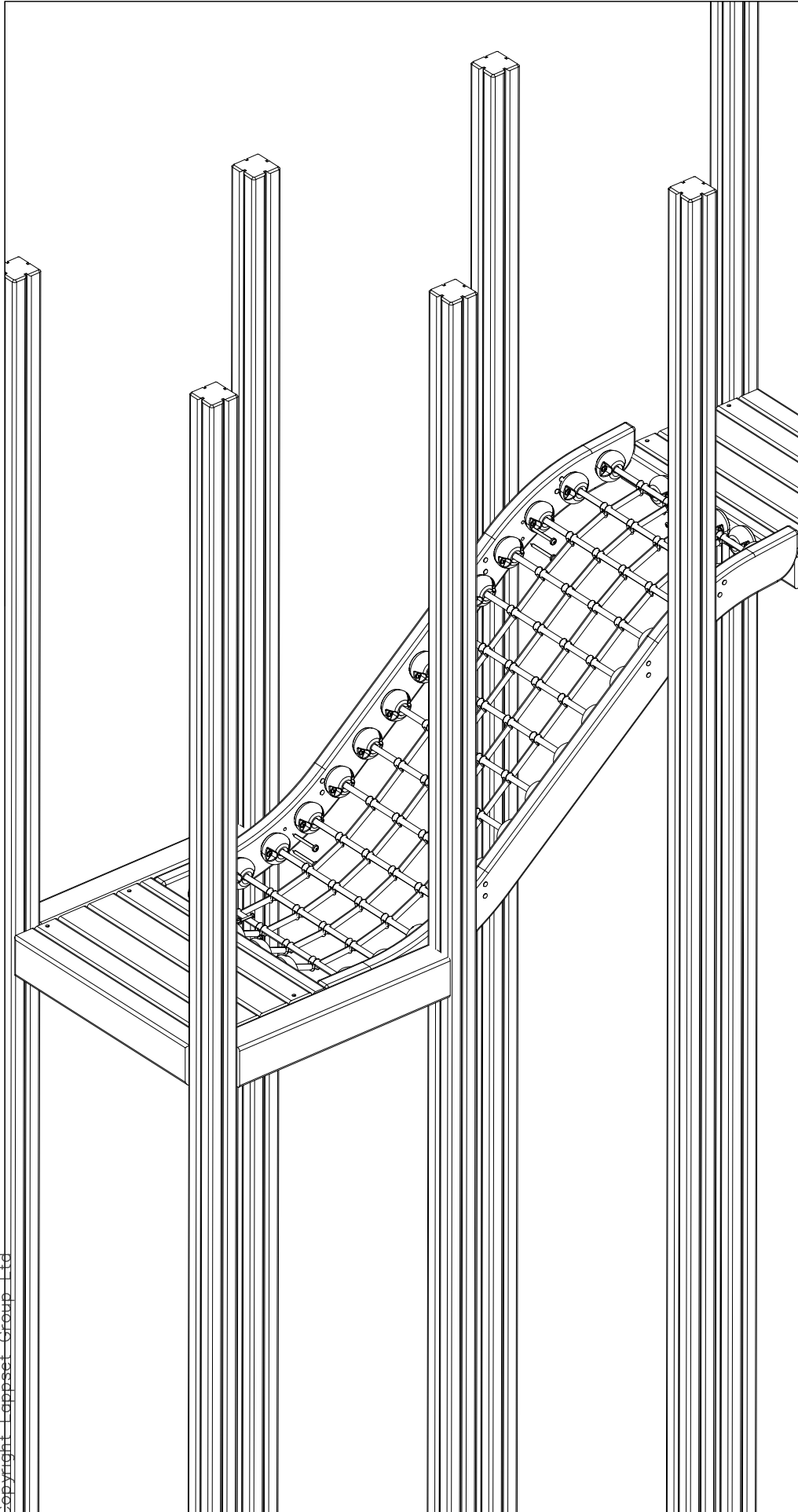

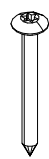
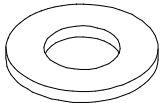
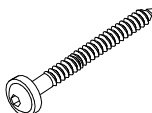
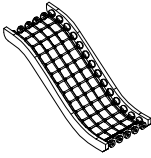
① 980123	PCS	① 909256	PCS
	16		16
Ø7x60		Ø16/8.4x1.6	
③ 903093	PCS		PCS
	8		
Ø8x90			
	PCS		PCS
	PCS		PCS
	PCS		PCS
	PCS		PCS
○ A10580	PCS		PCS
			



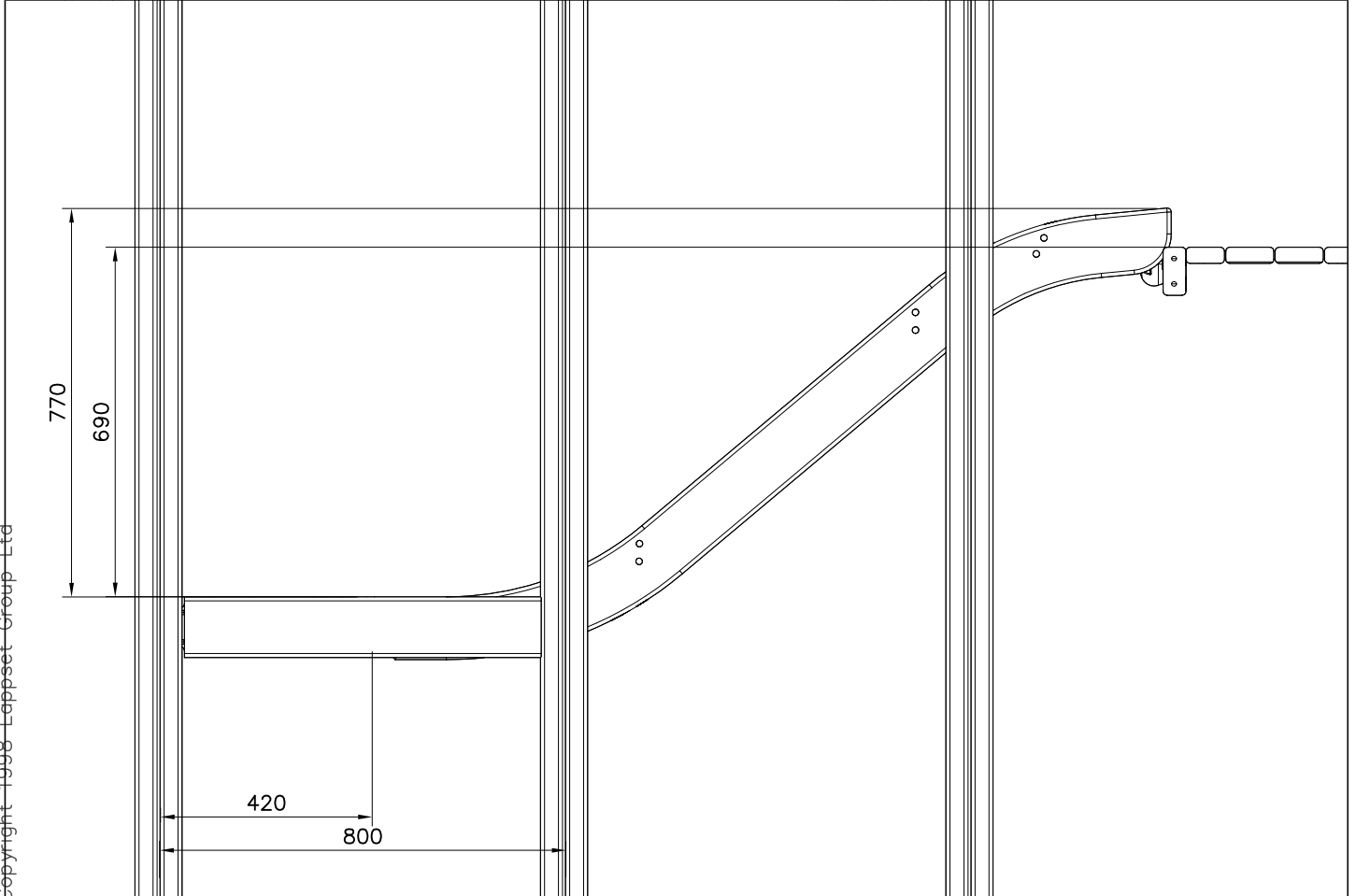
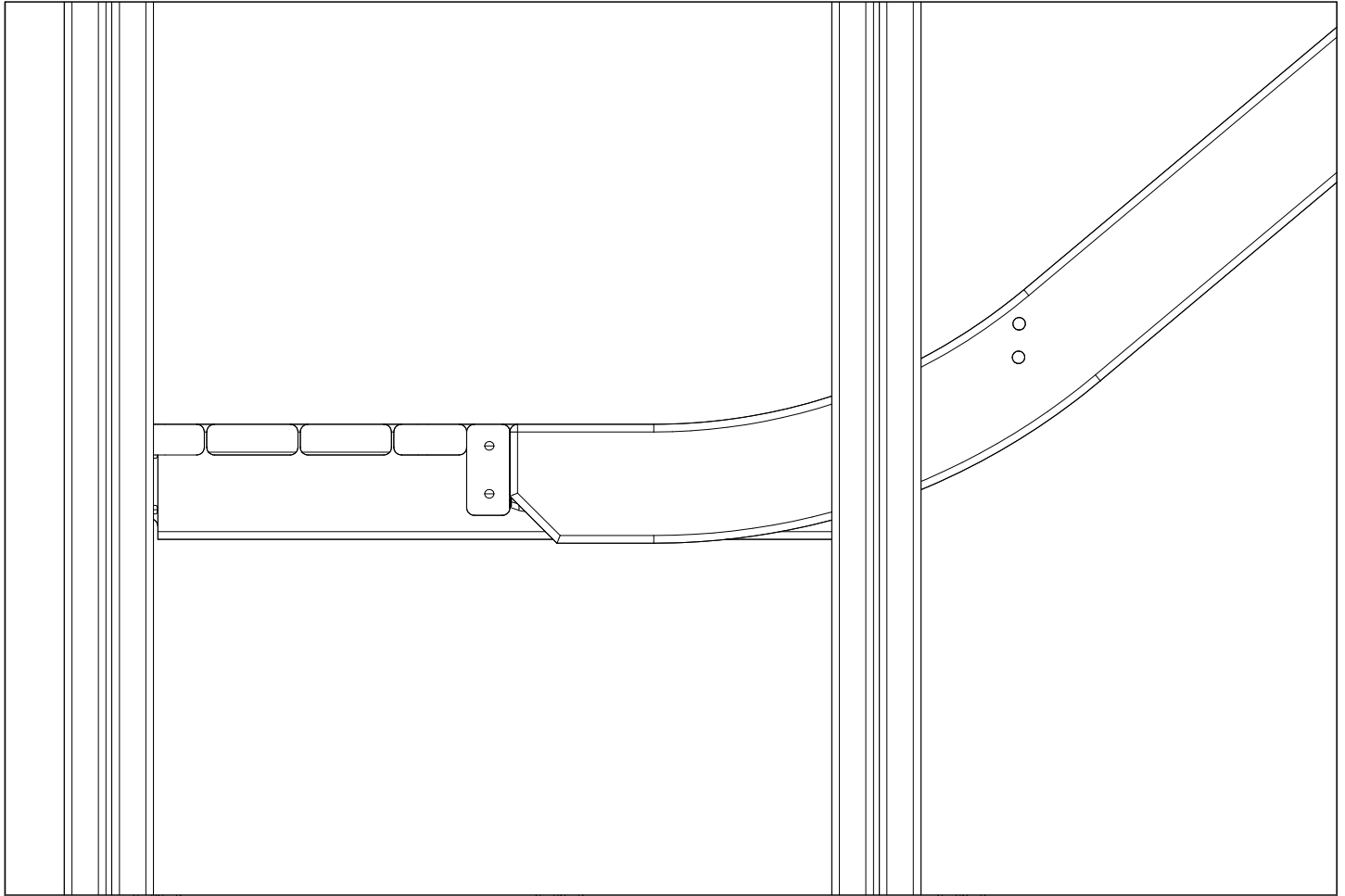

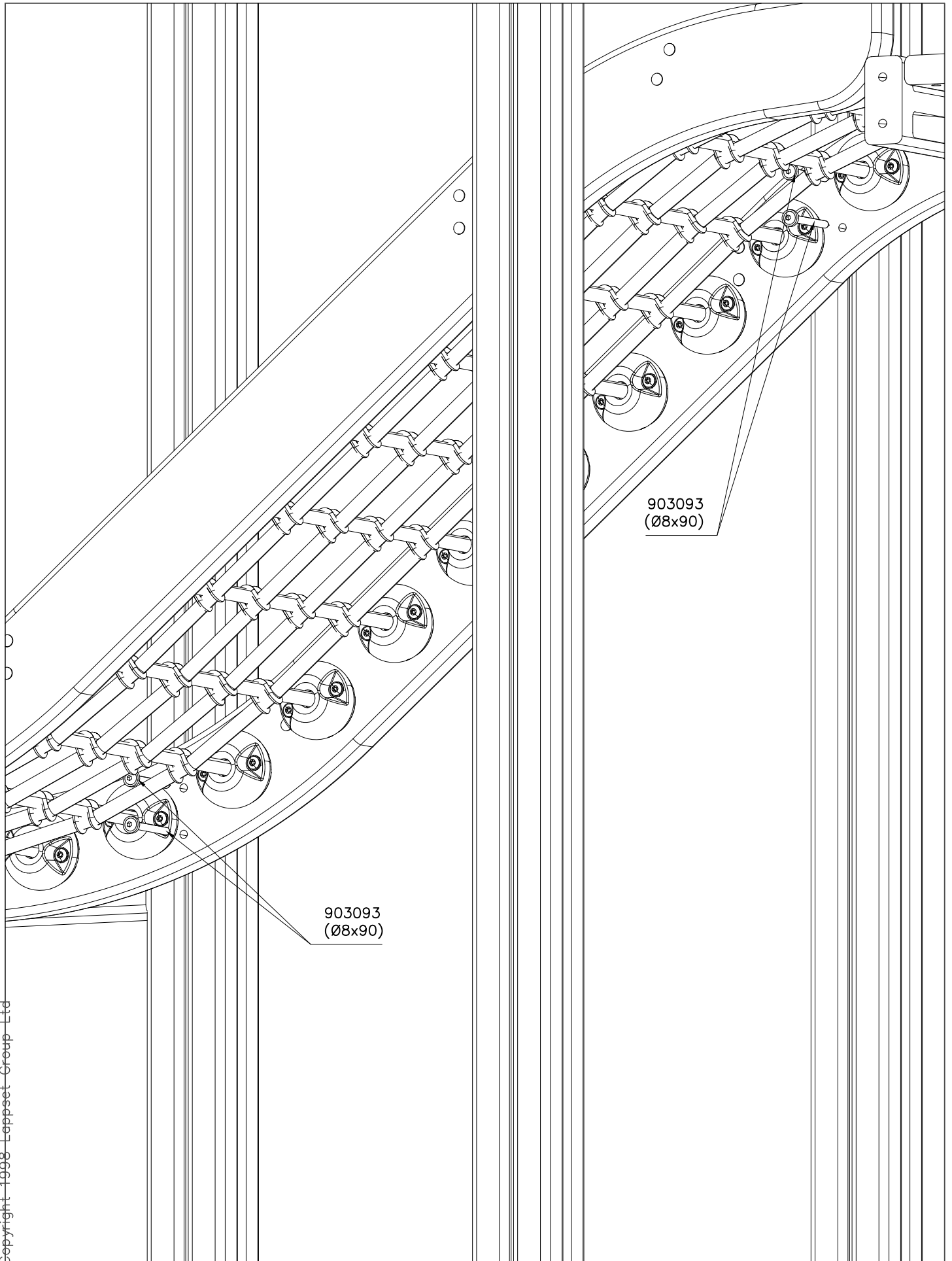

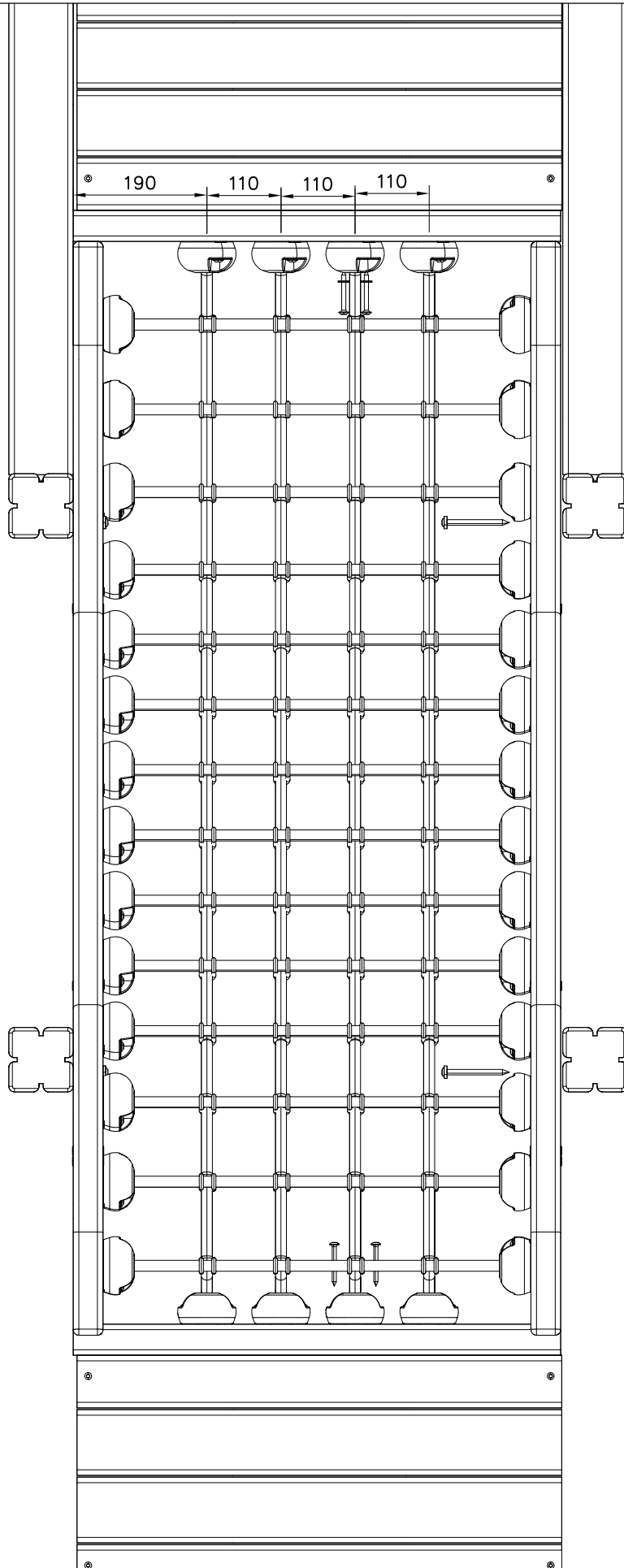

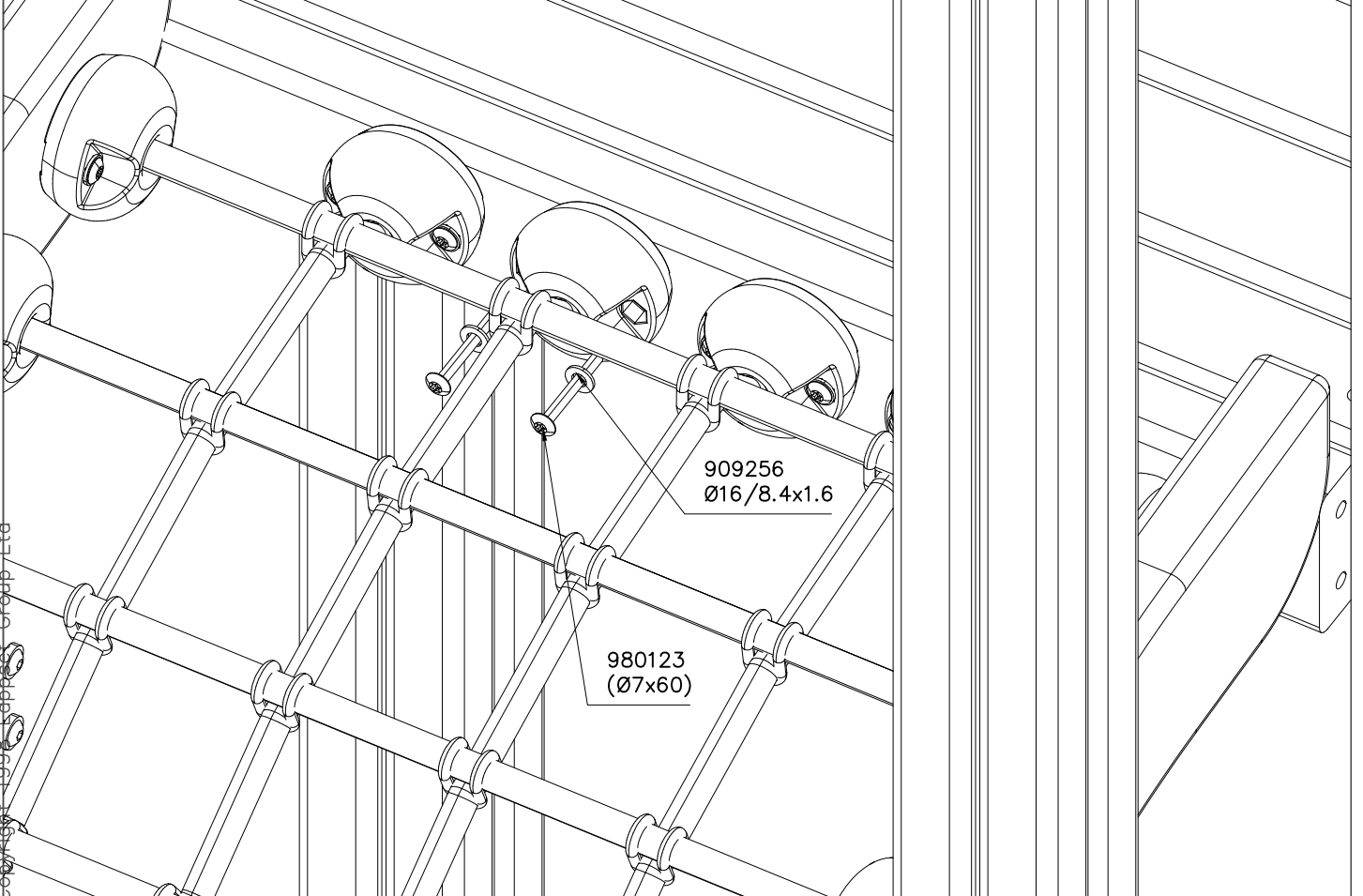
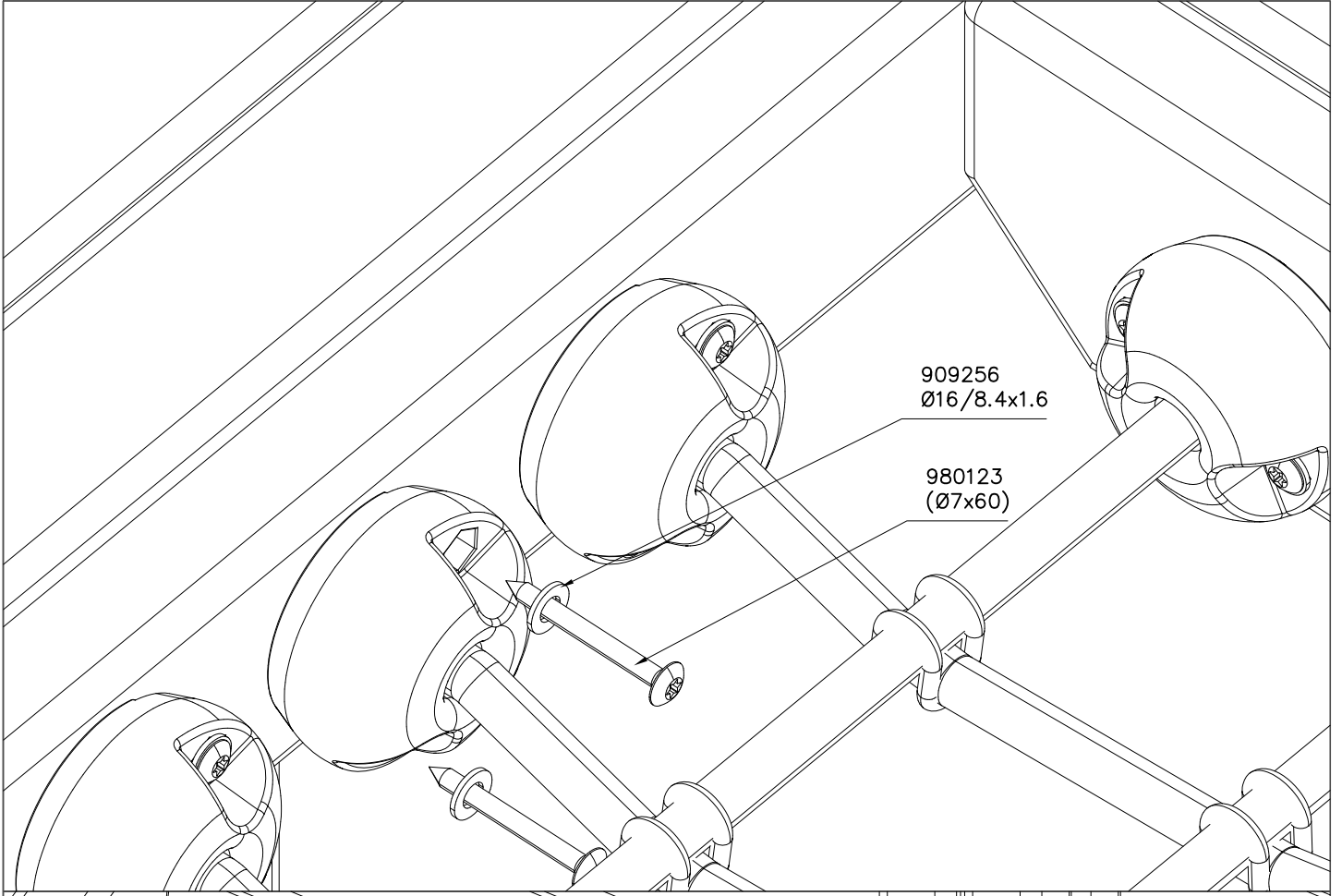

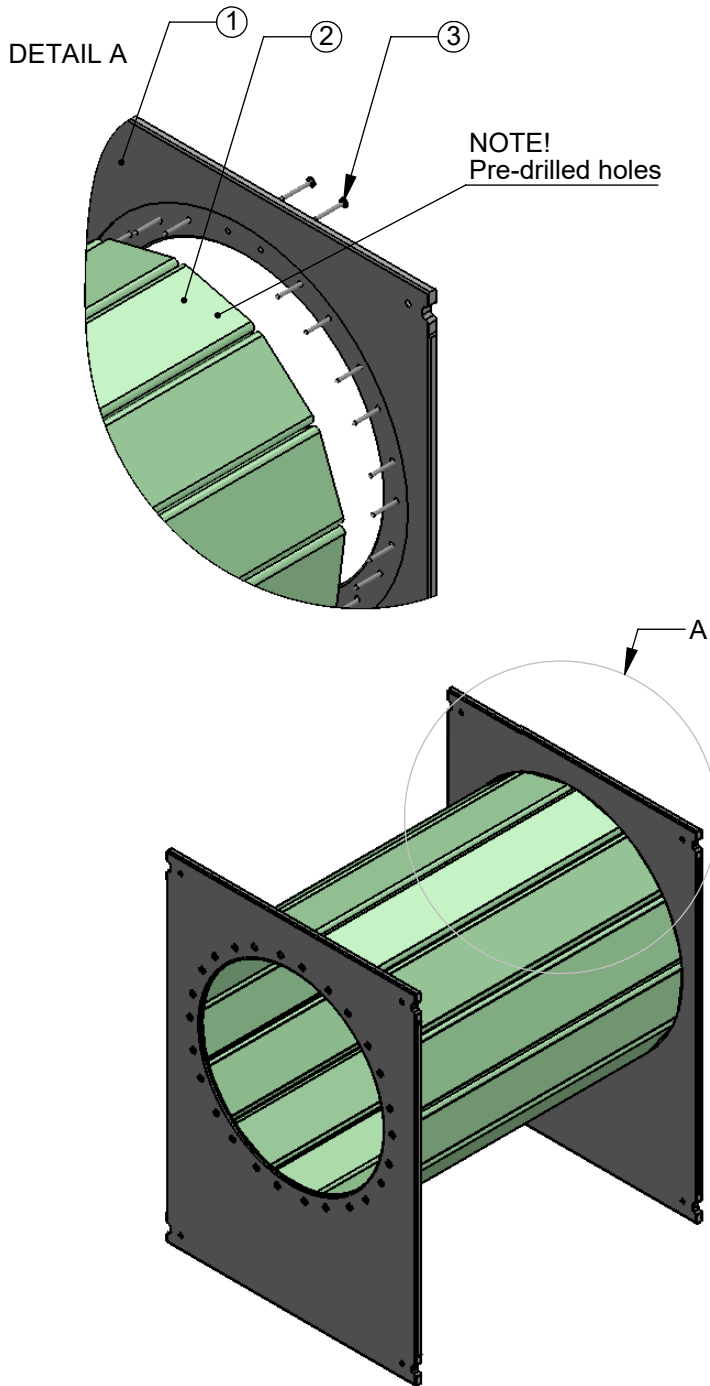

DETAIL B 1 : 7

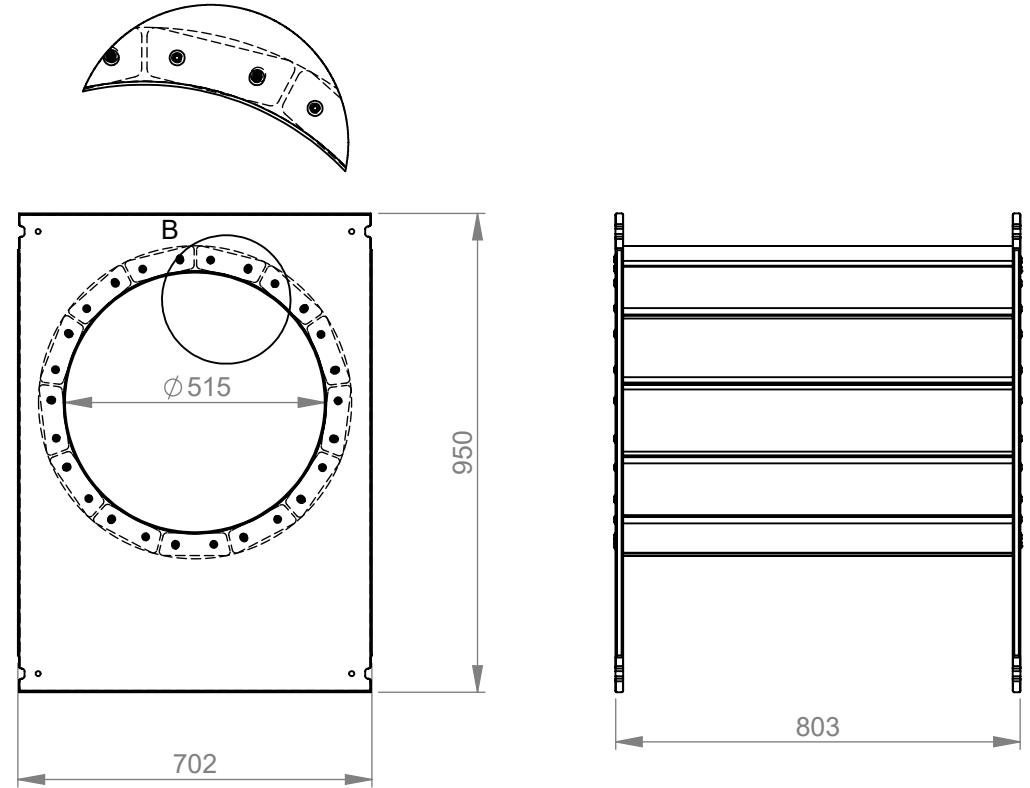

3	980123	SPECIAL SCREW	Ø7x60	52		STAINLESS STEEL
2	P15301	BEAM	45x145x	13		BILLET
1	P15300	PLATE	15x702x950	2		LAMINATE
part osa	code nimike	item description nimikkeen kuvaus	dimension koko	pcs kpl	amount määrä	material / note raaka-aine / lisätieto
description kuvaus				mass massa	54.787 kg	phase tila
CRAWLING TUNNEL M80				turn kääntö		Production Drawing
				item nr nimike nro	A10583	
revision revisio nro		arkki size	A4		tolerances yleistoleranssi	
1		page sivu	1/1		date päiväys	name nimi
scale suhte		des. suun.	29.04.21		LAAU	
1:15		check tark.	04.10.21		MS	
www.lappset.com			TEL +358 20 775 0100 FAX +358 20 775 0101 PL 8146 FI-96101 ROVANIEMI			

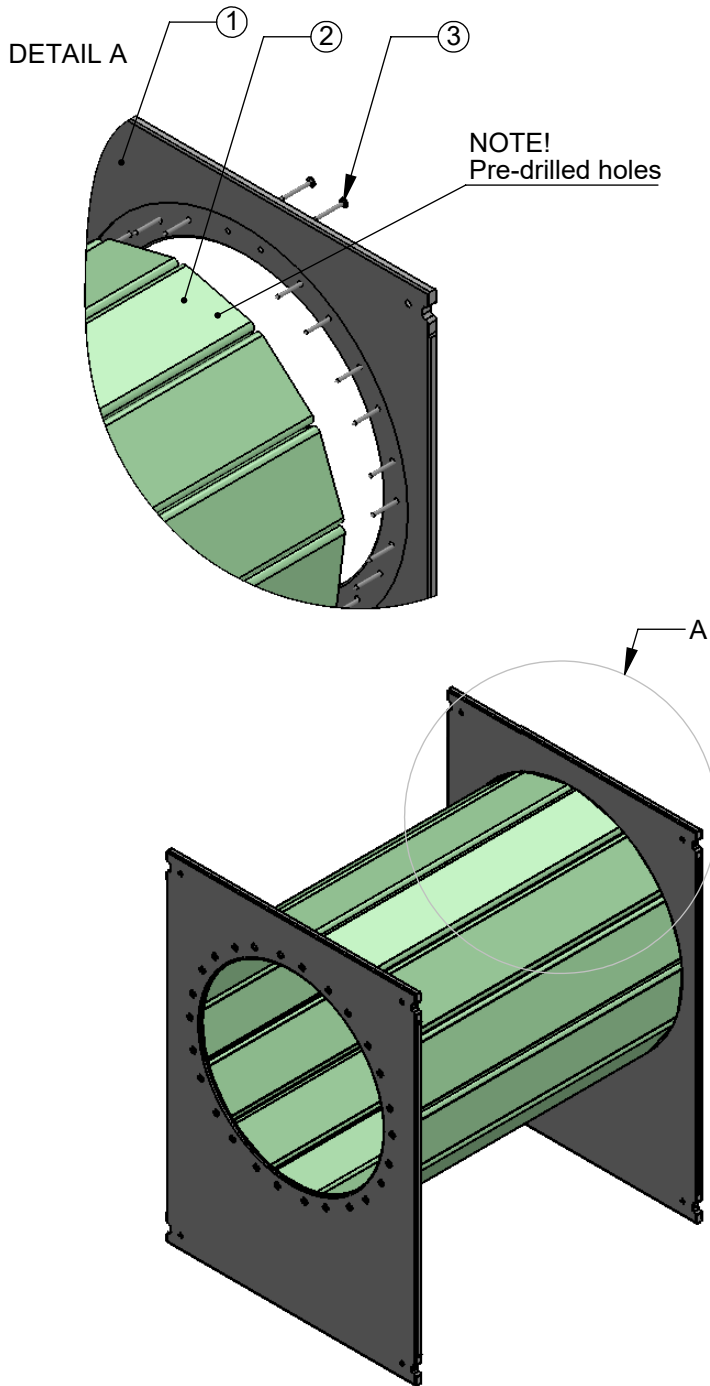

DETAIL B 1 : 7

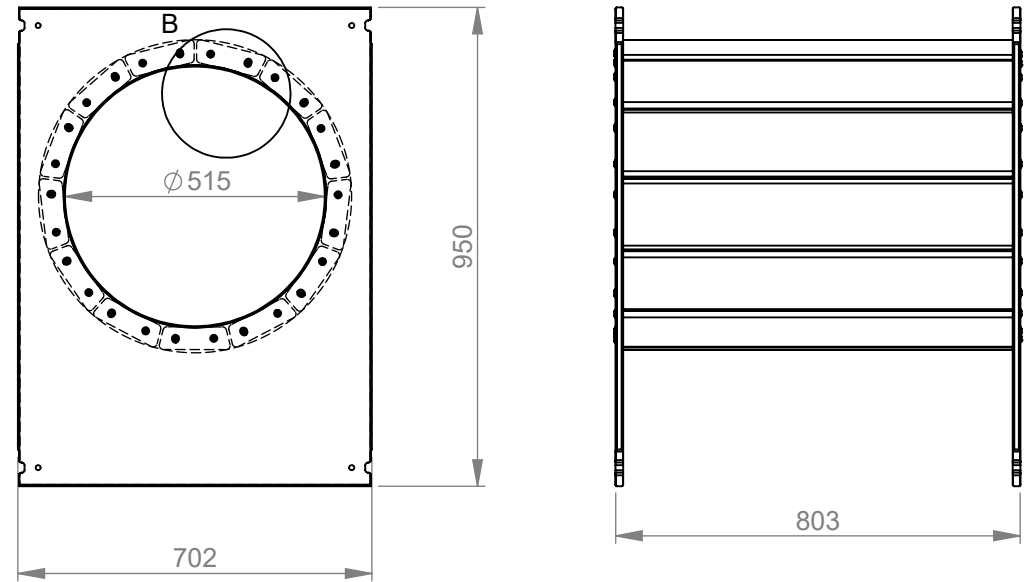

3	980123	SPECIAL SCREW	Ø7x60	52		STAINLESS STEEL
2	P15301	BEAM	45x145x	13		BILLET
1	P15300	PLATE	15x702x950	2		LAMINATE
part osa	code nimike	item description nimikkeen kuvaus	dimension koko	pcs kpl	amount määrä	material / note raaka-aine / lisätieto
description kuvaus				mass massa	54.787 kg	phase tila
CRAWLING TUNNEL M80				turn kääntö		Production Drawing
				item nr nimike nro	A10583	
revision revisio nro		arkki size	A4		tolerances yleistoleranssi	
1		page sivu	1/1		date päiväys	name nimi
scale suhde		des. suun.	29.04.21		LAAU	
1:15		check tark.	04.10.21		MS	
www.lappset.com			TEL +358 20 775 0100 FAX +358 20 775 0101 PL 8146 FI-96101 ROVANIEMI			

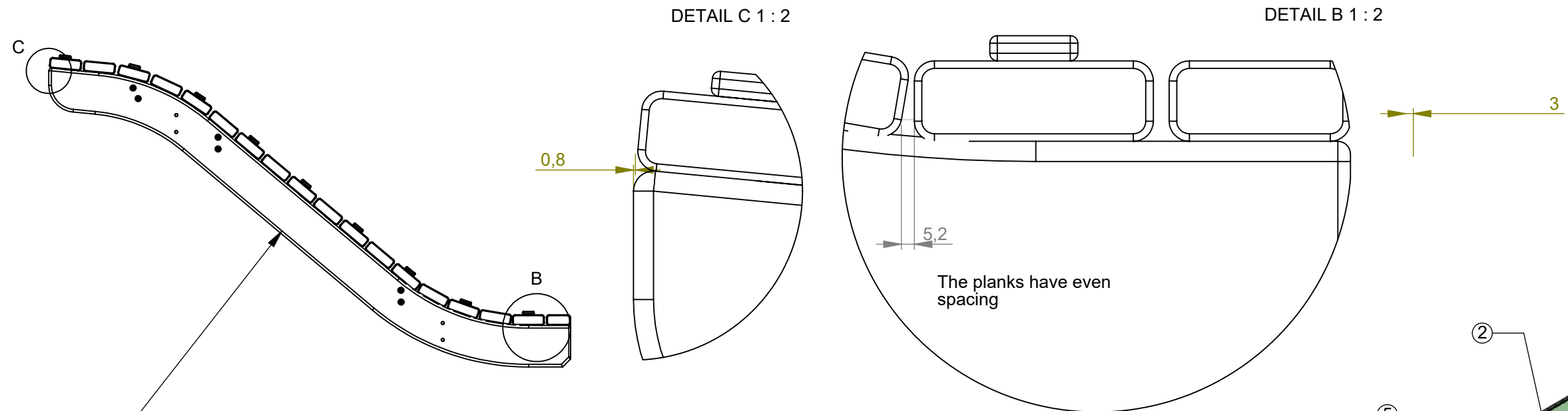

The side element's are almost the same as in slides. Place the laminate on the bottom side of the ramp

See more on the sheet 2

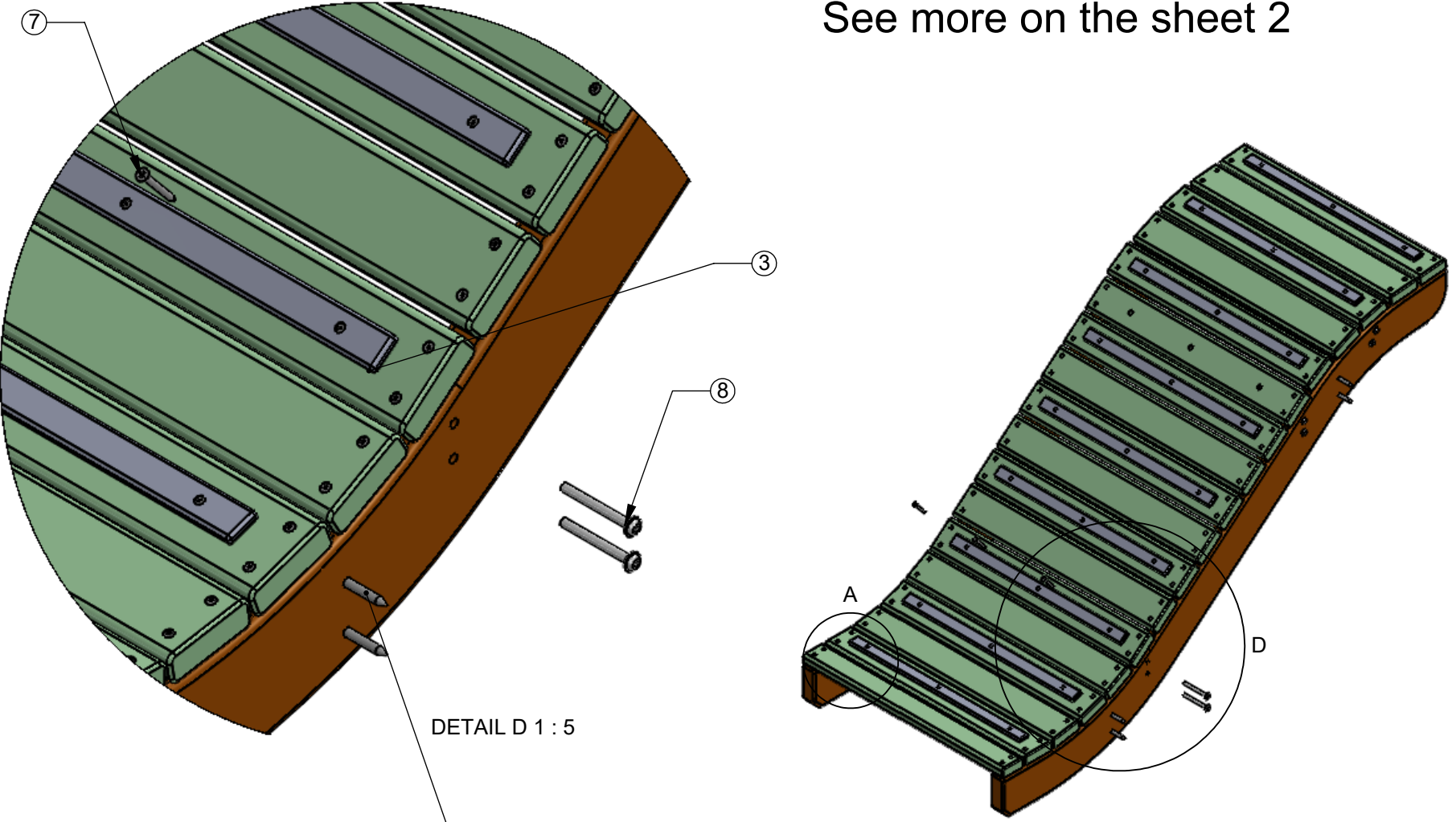

DETAIL D 1 : 5

The 8x 903093 are used for post attachment and delivered with the ramp as fitting

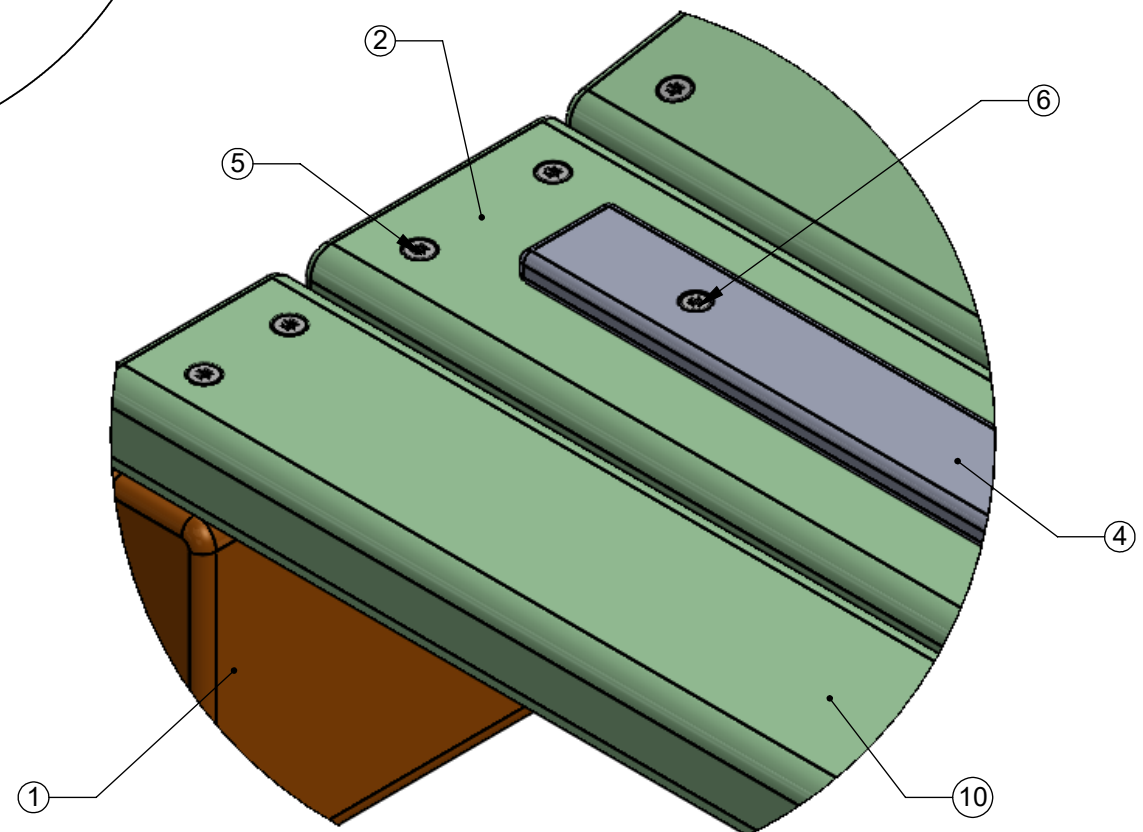

DETAIL A 1 : 2

part osa	code nimike	item description nimikkeen kuvaus	dimension koko	pcs kpl	amount määrä	material / note raaka-aine / lisätieto
11	P15237	BATTEN	32x95x700	3		BILLET
10	P15532	BATTEN	32x72x700	1		BILLET
9	903093	SPECIAL SCREW	Ø8x90	8		STAINLESS STEEL
8	901104	ALLEN SCREW	M8x80	12		ISO 7380, A2
7	980107	SCREW	Ø6x60	9		A2 WAX
6	980110	SCREW	Ø4x35	27		A2 WAX
5	980101	SCREW	Ø4.5x70	76		A2/A2
4	P15238	PLATE	10x35x600	9		LAMINATE
3	P15245	BOOM	45x95x618	3		
2	P15236	BATTEN	32x95x700	14		BILLET
1	P15531	S-KAARI	43x780x1558	2		S-KAARI AIHIO*

description  
kuvaus  
**RAMP**

mass  
massa  
58.009 kg

turn  
kääntö

revision  
revisio nro  
1

arkki  
size  
A3

page  
sivu  
1/2

scale  
suhde  
1:15

des.  
suun.  
03.06.21

check  
tark.  
24.06.21

material / note  
raaka-aine / lisätieto  
Production Drawing

item nr  
nimike nro  
A10602

tolerances  
yleistoleranssi  
LS01-001

date  
päiväys  
03.06.21

name  
nimi  
TOKE

www.lappset.com

TEL +358 20 775 0100  
FAX +358 20 775 0101

PL 8146  
FI-96101 ROVANIEMI

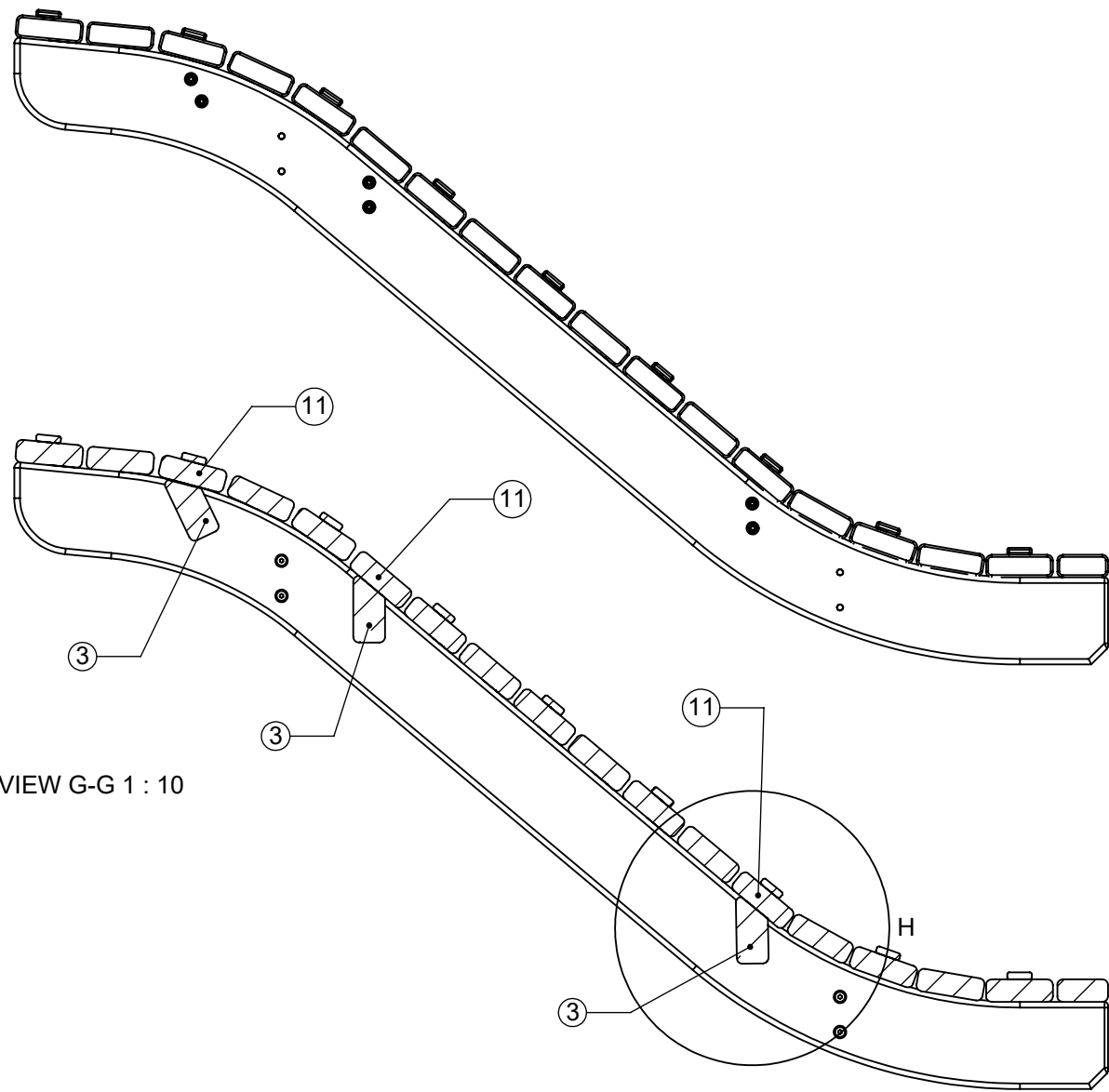

VIEW G-G 1 : 10

Boom 3 placements are determined by the holes

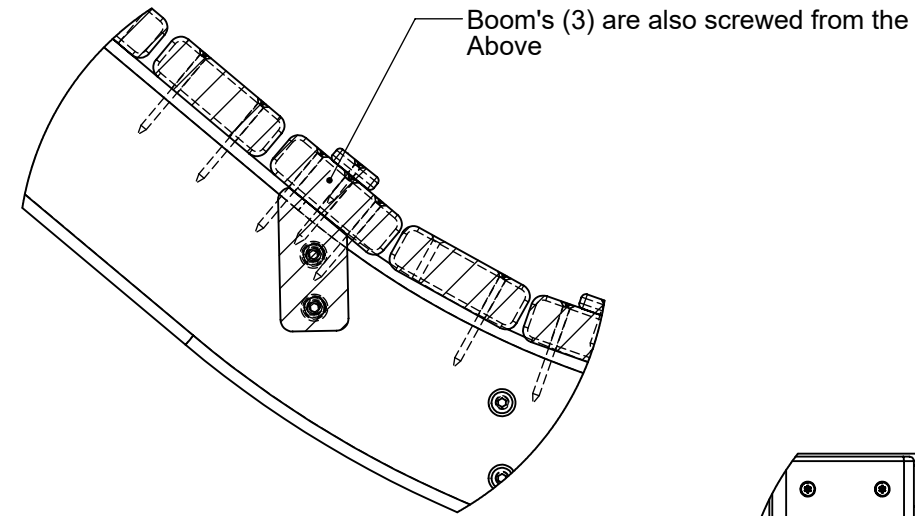
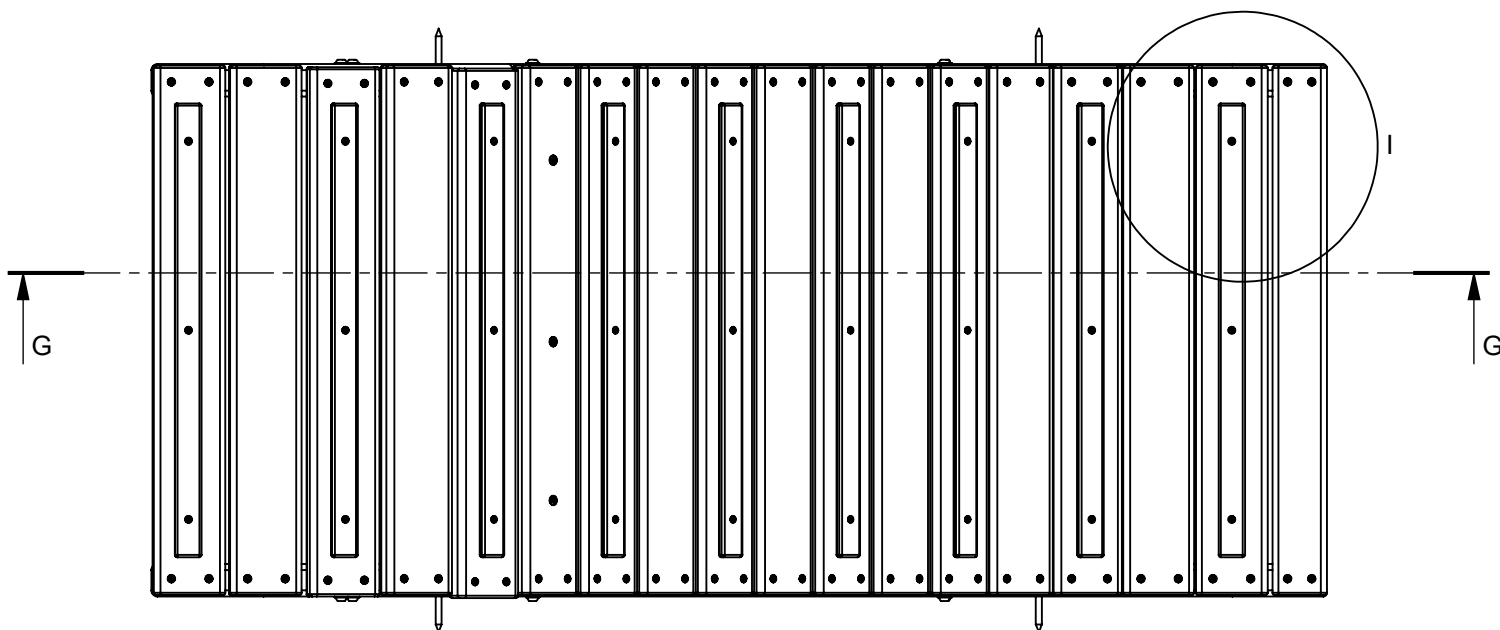

DETAIL H 1 : 5

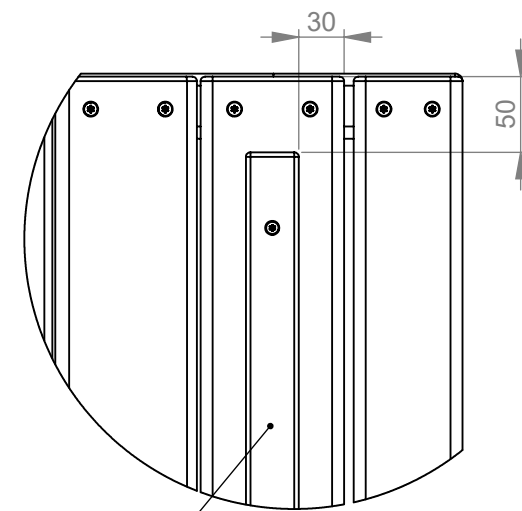

DETAIL I 1 : 5

part osa	code nimike	item description nimikkeen kuvaus	dimension koko	pcs kpl	amount määrä	material / note raaka-aine / lisätieto
description kuvaus <b>RAMP</b>				mass massa	<b>58.009 kg</b>	phase tila <b>Production Drawing</b>
				turn kääntö		item nr nimike nro <b>A10602</b>
revision revisio nro <b>1</b>				arkki size page sivu	<b>A3</b> <b>2/2</b>	tolerances yleistoleranssi <b>LS01-001</b>
www.lappset.com				scale suhde <b>1:15</b>	des. suun. <b>03.06.21</b>	name nimi <b>TOKE</b>
				check tark.	<b>24.06.21</b>	<b>TOKE</b>

date  
päiväys









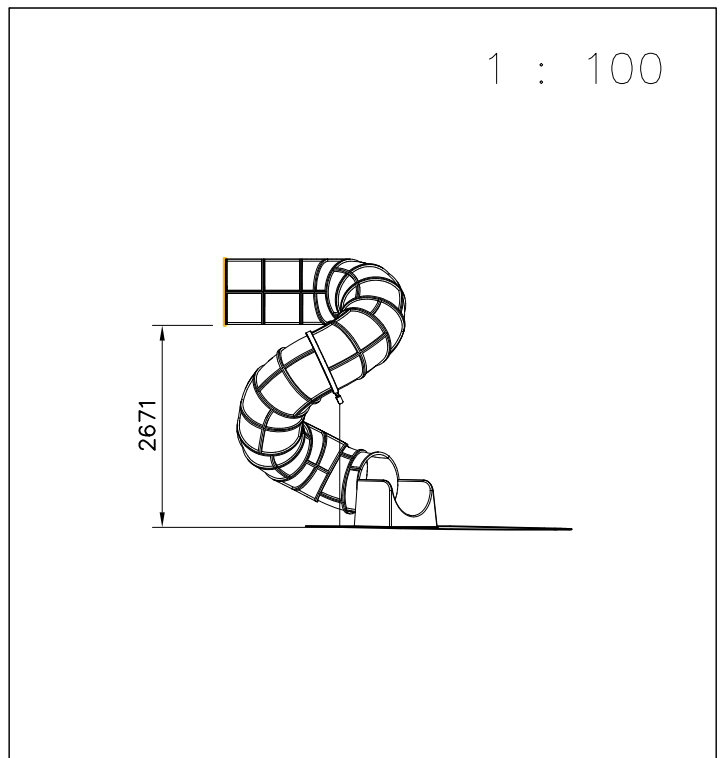
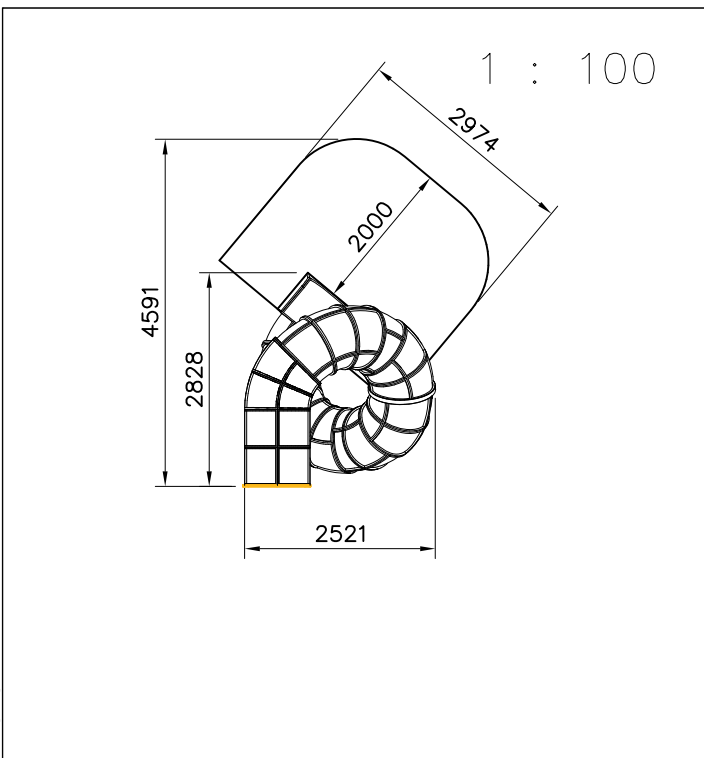
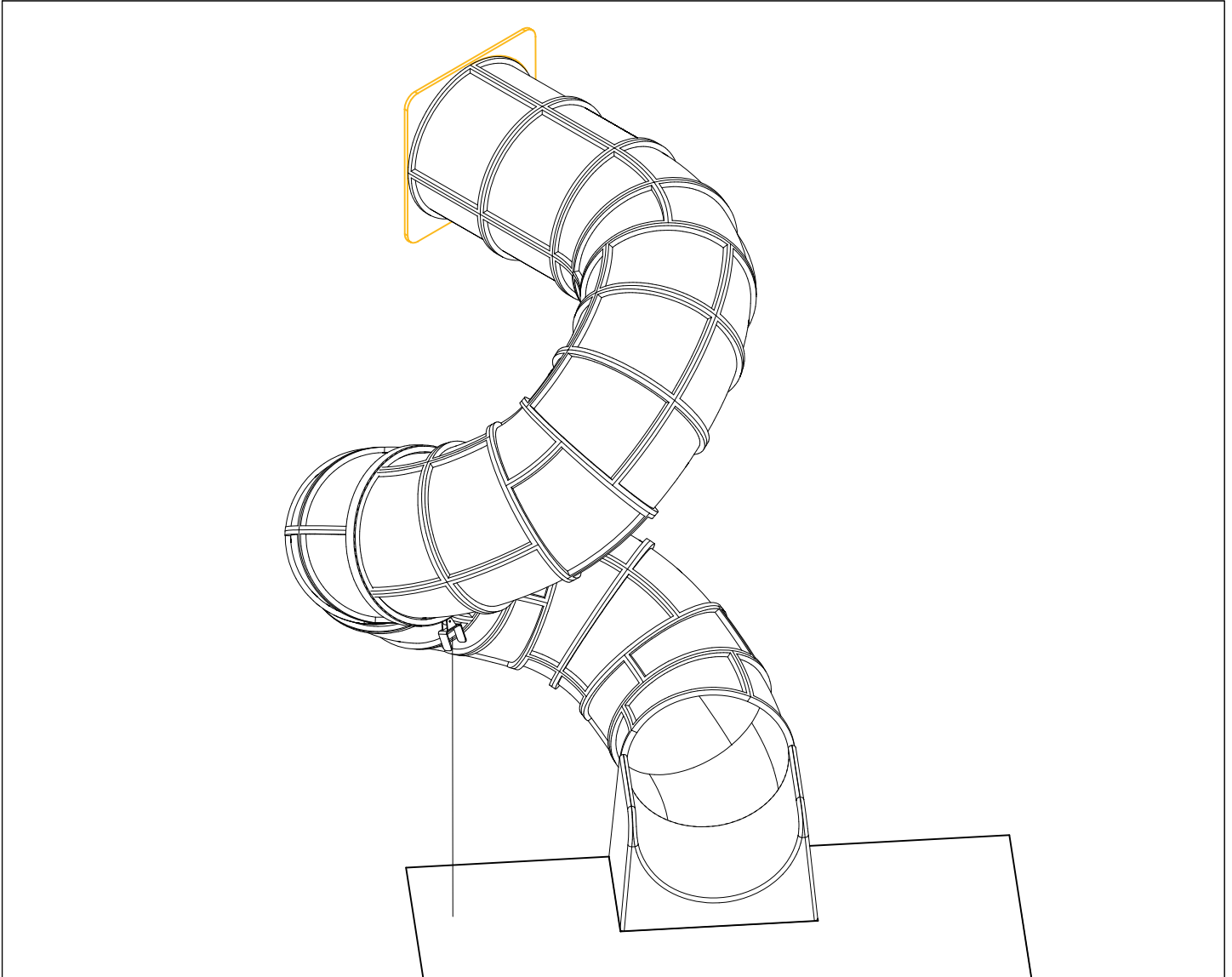

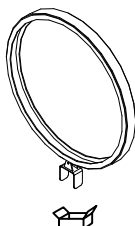
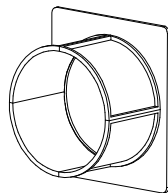
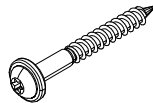
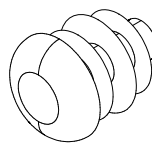
name  
nimi

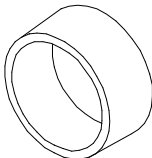
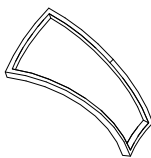
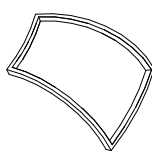
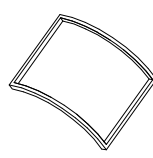
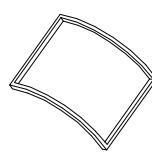
note  
huom.

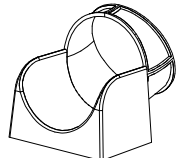
Alteration  
Muutoskenttä

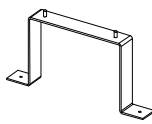

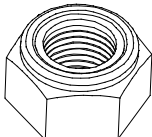
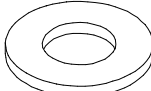

	PCS	004914	PCS	707918-702	PCS	900240	PCS	903533	PCS	905086	PCS
			1		1		14		6		4
						Ø8x70		SRL12		Ø44/13.5	
905112	PCS	905803	PCS	905813	PCS	905823	PCS	905829	PCS	905831	PCS
	976		34		34		2		2		904
BLACK Ø22		YELLOW		YELLOW		YELLOW		TRANSPARENT		BLACK	
905850	PCS	905859	PCS	905860	PCS	909205	PCS	909248	PCS	909274	PCS
	1		2		2		452		4		4
		6x80x850				8x60		M12		8x30	
980150	PCS	980151	PCS		PCS		PCS		PCS		PCS
	456		8								
M8		Ø16/8.4									
	PCS		PCS		PCS		PCS		PCS		PCS
	PCS		PCS		PCS		PCS		PCS		PCS

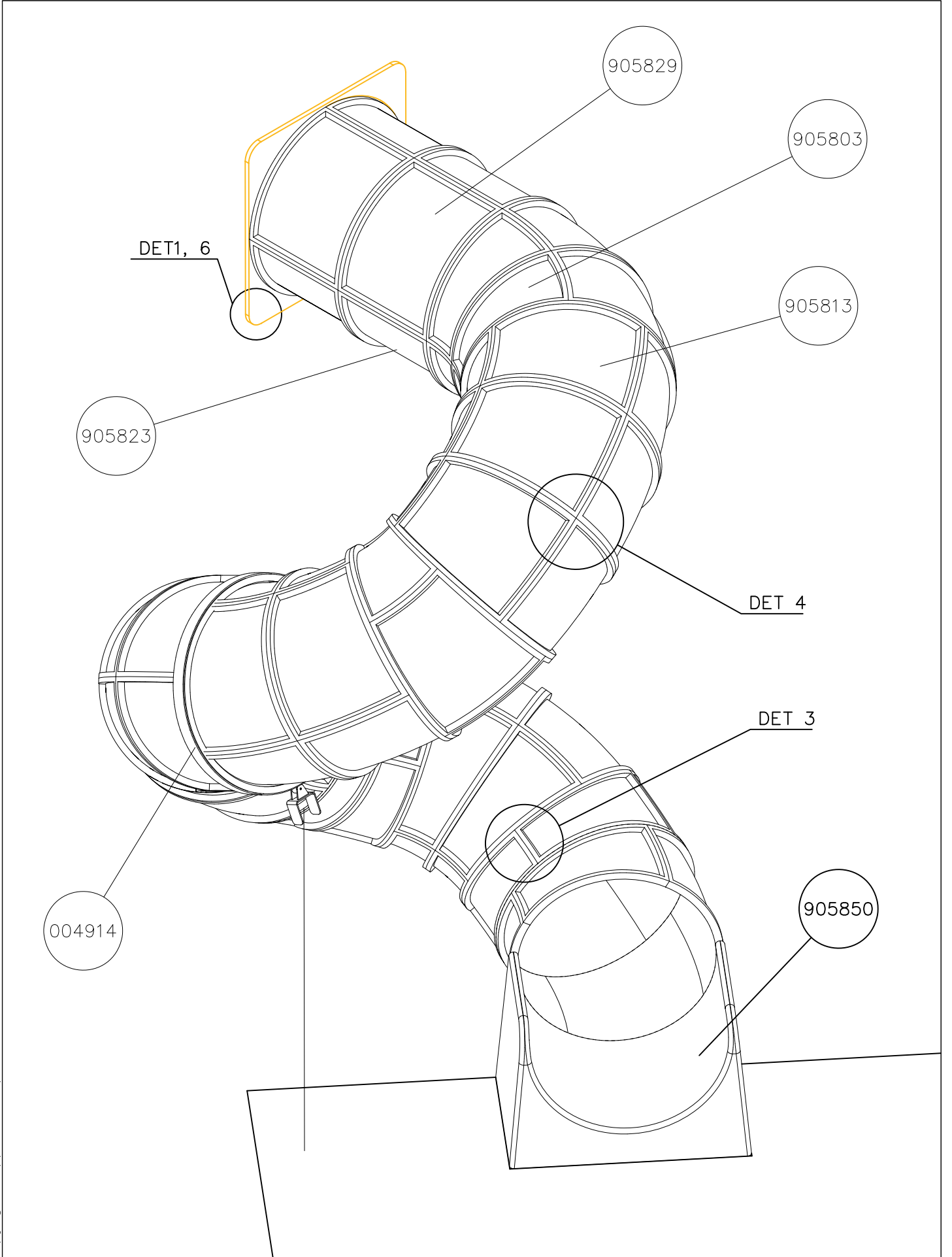

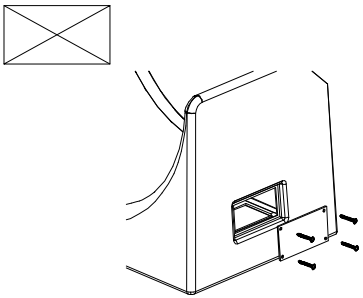
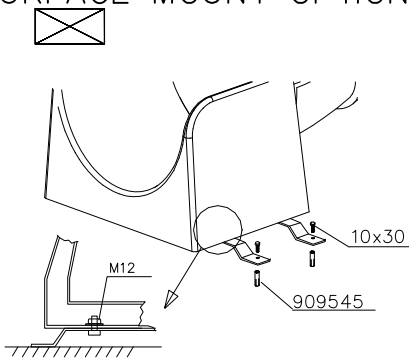
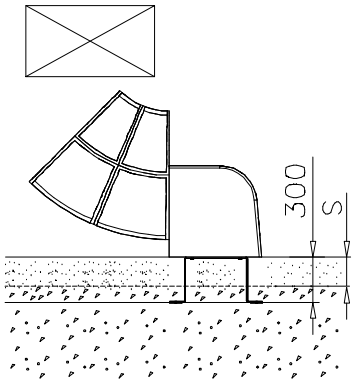
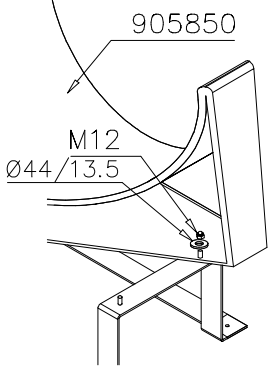
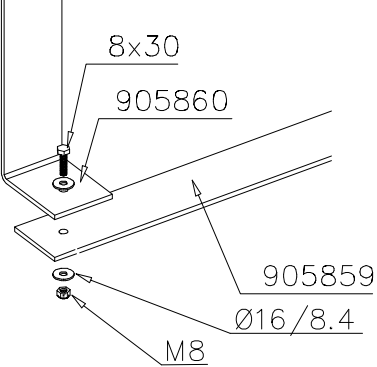
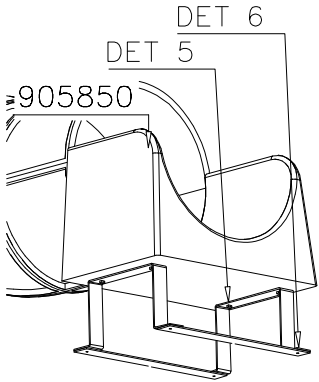
<p>905850</p>  <p>Access- and maintenance panel. Asennus- ja huolto luukku.</p>	<p>905850 SURFACE MOUNT OPTION</p>  <p>10x30 909545 M12</p>	<p>905850</p>  <p>300 S</p>
<p>905850</p>  <p>905850 M12 Ø44/13.5</p>	<p>905850</p>  <p>8x30 905860 905859 Ø16/8.4 M8</p>	<p>905850</p>  <p>DET 6 DET 5 905850</p>

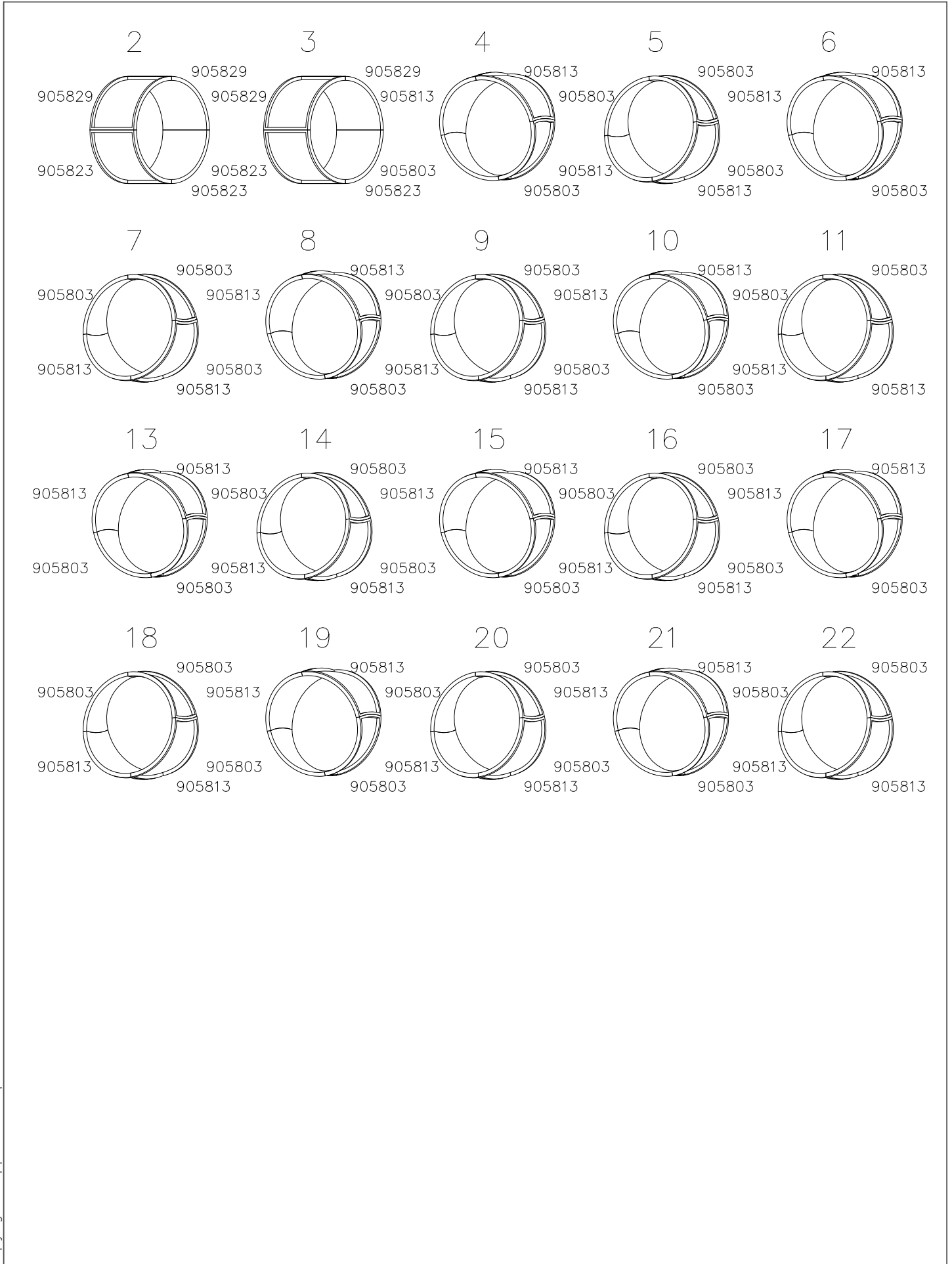

**Esimerkki putken kokoamisesta**  
**Example of installation**





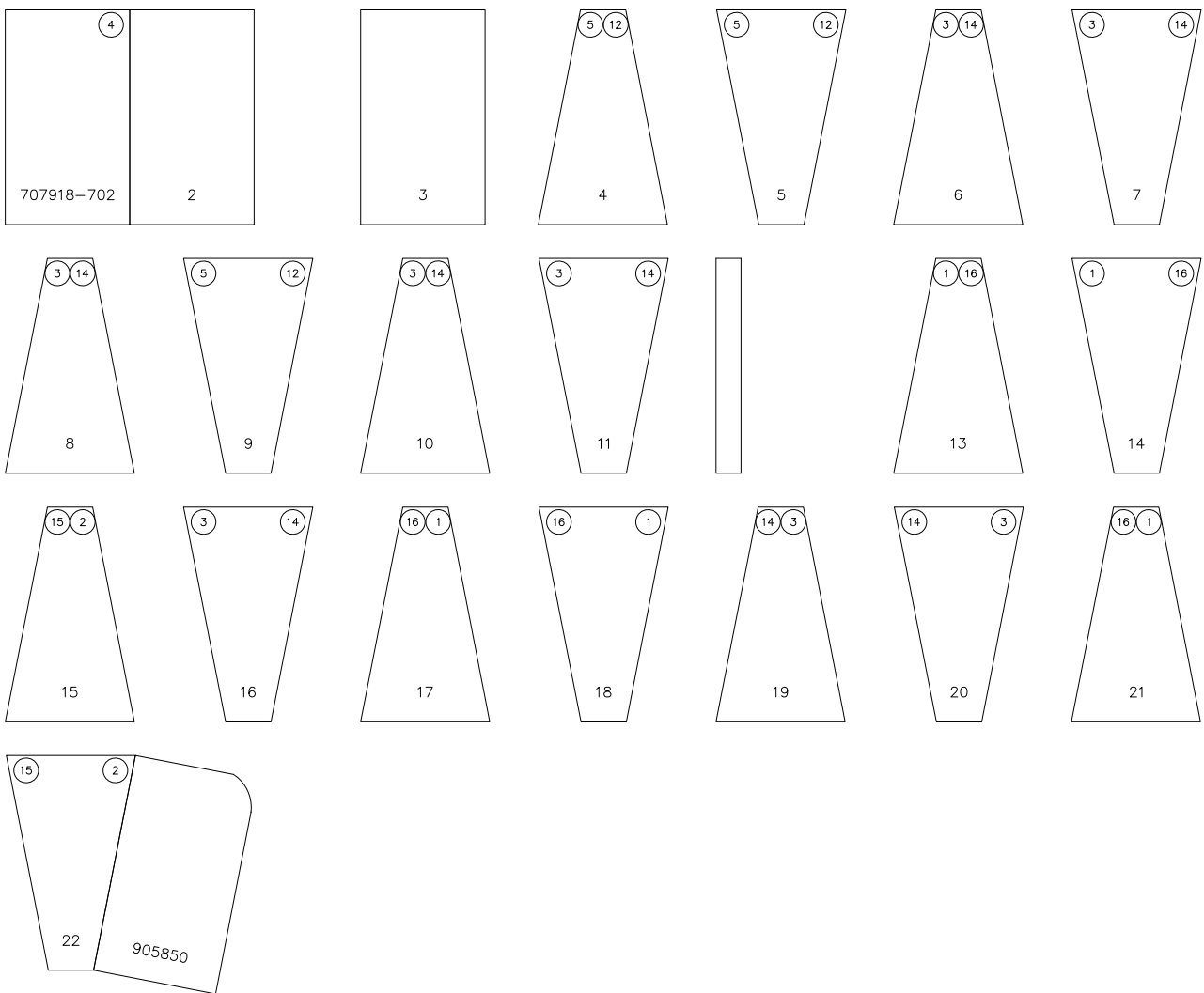
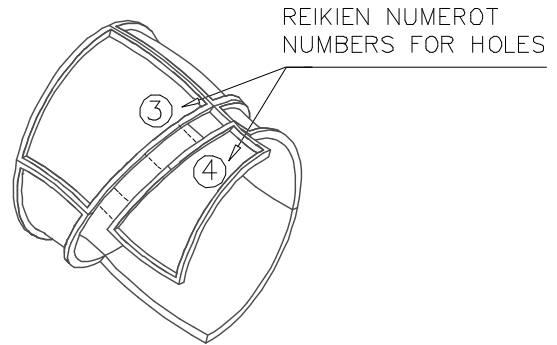

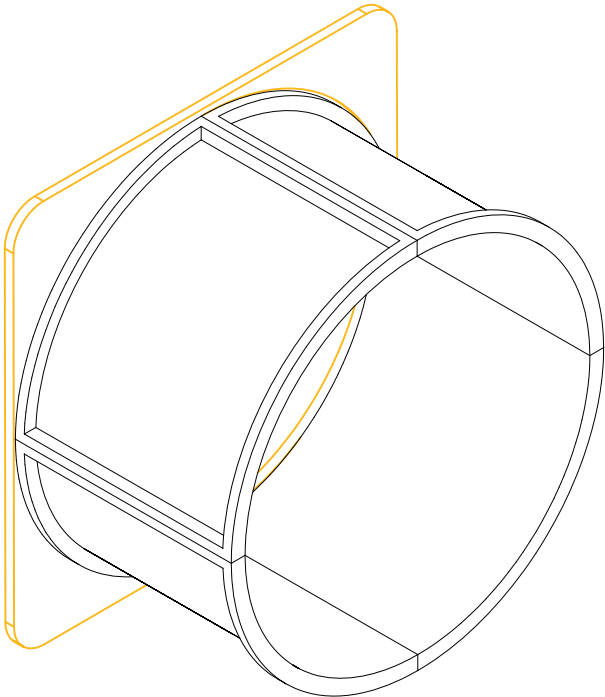
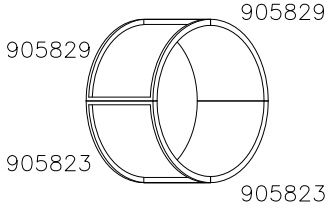
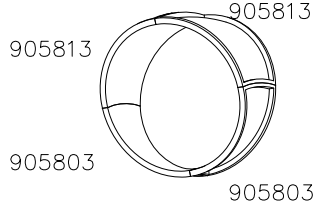

**LIUKUPINTAAN EI SAA TULLA**  
**LÄPINÄKYVIÄ MODUULEJA!!**

**NO TRANSPARENT PIECES ON**  
**SLIDING SURFACE!!**

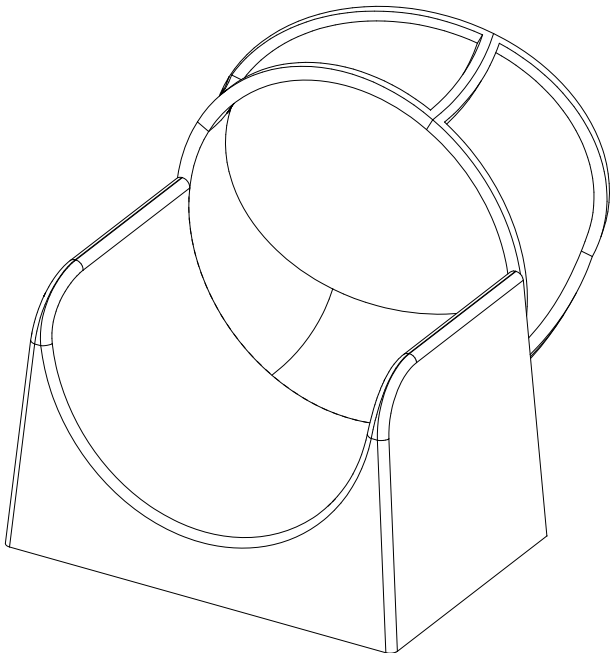

Valmiiksi kasattujen osien osakokoonpanot ja vara-osa listat.

Ready installed component subassemblies and spare part list.

	<p>2</p> 								
<p>22</p>  <table border="1" data-bbox="172 1724 742 2101"> <tr> <td>909205 x 16 909206 x 8</td> <td>980150 x 16</td> <td>905831 x 32</td> </tr> <tr> <td>905850</td> <td>909208 x 8</td> <td>980151 x 8</td> </tr> </table>	909205 x 16 909206 x 8	980150 x 16	905831 x 32	905850	909208 x 8	980151 x 8	<p>909252 x 13</p> 	<p>700413 x 1</p> 	 <p>Position of the box: 151 degrees</p>
909205 x 16 909206 x 8	980150 x 16	905831 x 32							
905850	909208 x 8	980151 x 8							
	<p>707918-702</p> 	<p>909205 x 12</p> 	<p>980150 x 12</p> 						
	<p>905831 x 40</p> 	<p>909208 x 16</p> 	<p>909119 x 16</p> 						

DET 1



DET 2



DET 3



DET 4

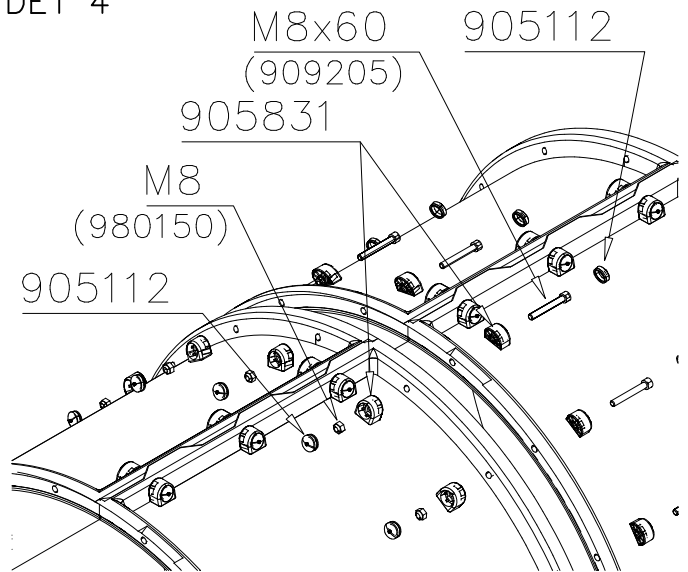

DET 5



DET 6

