

LAPPSET®

CUBIC







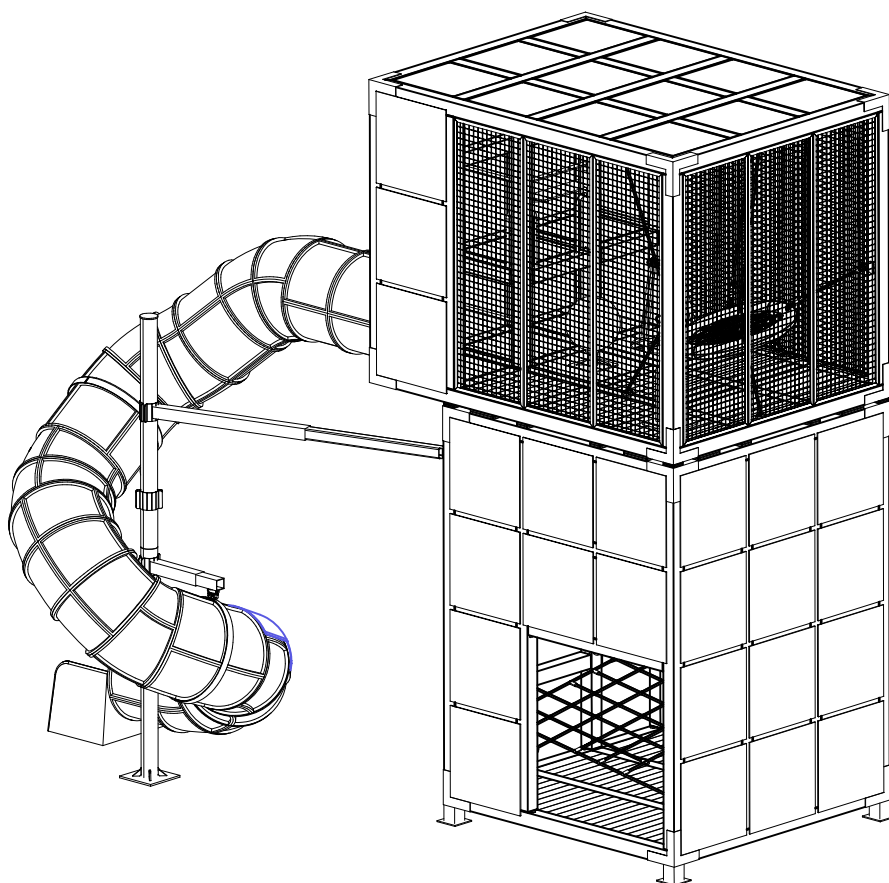



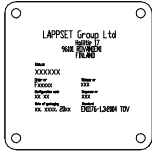
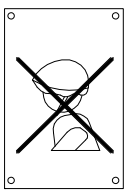
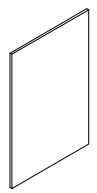
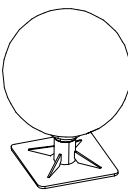
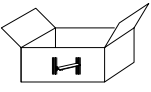
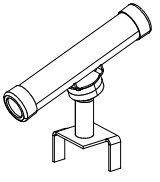
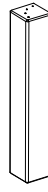

ASENNUSOHJE
MONTERINGSANSVISNING
INSTALLATION INSTRUCTION
AUFBAUANLEITUNG
NOTICE D'INSTALLATION



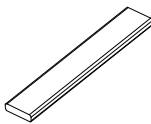
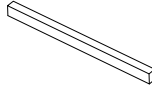
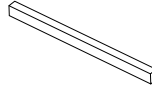

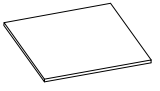
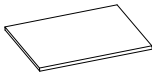
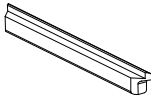
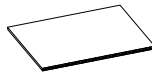
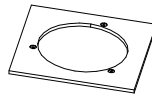
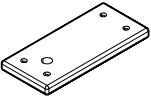
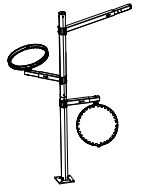
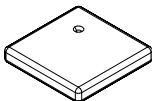
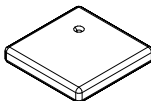
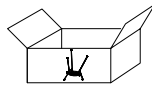
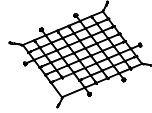
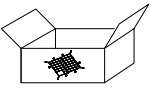

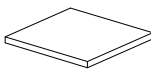
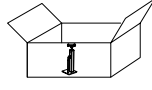
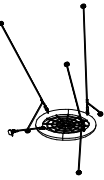
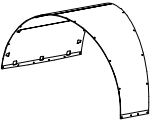
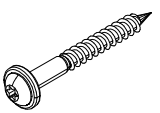
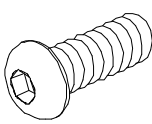

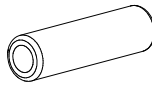
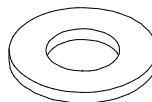
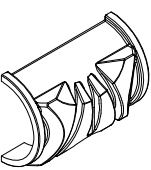
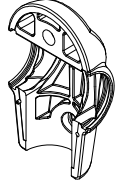

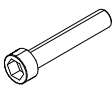
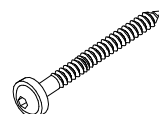

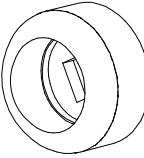
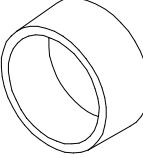
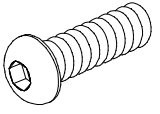
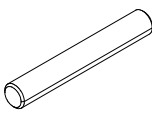
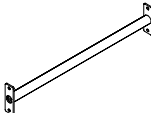

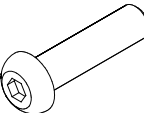
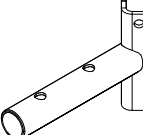

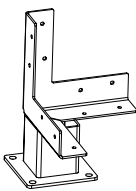
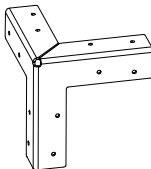
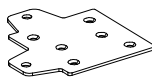

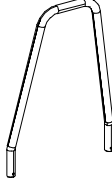
DATE: 13.3.2020

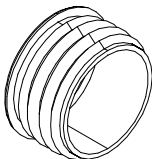
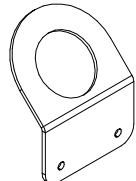
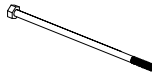
239022M

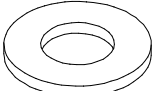
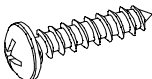
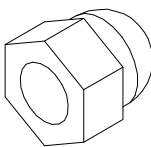
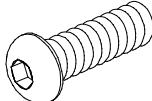
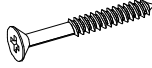

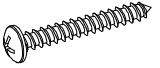
DATE: 13.3.2020

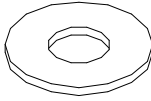
| | | | | | | | | | | | |
|--|-----------|---|------------|---|-----------|---|-----------|---|-----------|---|-------------|
| 702286  65x65 | PCS 1 | 702339  118x78 | PCS 1 | 702533  118x78 | PCS 1 | 703616  Ø450 | PCS 1 | 706753  | PCS 1 | 707304  1 | PCS 1 |
| 708109-614  118x118x697 | PCS 65 | 708110-614  118x118x1522 | PCS 4 | 708111-614  118x118x2345 | PCS 17 | 708114-614  118x118x3168 | PCS 12 | 708194-614  118x118x2573 | PCS 12 | 708202-614  118x118x3396 | PCS 4 |
| 708221  701x695x32 | PCS 16 | 708223  32x120x700 | PCS 6 | 708225  32x45x640 | PCS 48 | 708226  32x45x793 | PCS 12 | 708228  8x785x785 | PCS 54 | 708229  20x702x702 | PCS 1 |
| 708230  20x670x670 | PCS 5 | 708234-614  45x68x700 | PCS 100 | 708235  16x670x670 | PCS 20 | 708244  20x702x702 | PCS 1 | 708258  20x118x260 | PCS 32 | 708296  1 | PCS 1 |
| 708301  15x118x118 | PCS 8 | 708302  20x118x118 | PCS 8 | 708323  1 | PCS 1 | 708339-305  2325x2325 | PCS 3 | 708348  3 | PCS 3 | 708350  15x190x700 | PCS 1 |
| 708351-614  93x93x724 | PCS 1 | 708352  20x320x320 | PCS 1 | 708353  1 | PCS 1 | 708633-305  1 | PCS 1 | 708686  2 | PCS 1 | 900240  Ø8x70 | PCS 1064 |
| 900342  M8x16 | PCS 2 | 900727  M10x80 | PCS 4 | 901182  Ø11/M8x40 | PCS 1 | 901302  Ø20/10.5x2 | PCS 11 | 901900  2 | PCS 2 | 901902  30.7x60.9x100 | PCS 2 |

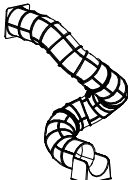
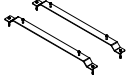
| | | | | | | | | | | | |
|---|------------|---|------------|---|-----------|---|-------------|---|------------|---|------------|
| 902232 | PCS 4 | 903093 | PCS 8 | 904450 | PCS 16 | 905090 | PCS 4 | 905115 | PCS 4 | 905827 | PCS 30 |
|  | |  | |  | |  | |  | |  | |
| M10x55 | | Ø8x90 | | M16x170 | | Ø45 | | Ø30 | | M8x20 | |
| 905984 | PCS 16 | 907694-216 | PCS 4 | 907701-216 | PCS 6 | 907727 | PCS 3 | 907783-216 | PCS 2 | 908699 | PCS 180 |
|  | |  | |  | |  | |  | |  | |
| Ø12x80 | | L 704 | | 40x545x114 | | M10x40 | | | | 3x180x108 | |
| 908828-221 | PCS 4 | 908829-221 | PCS 12 | 908835 | PCS 16 | 908949 | PCS 9 | 908966-216 | PCS 1 | 908967-216 | PCS 1 |
|  | |  | |  | |  | |  | |  | |
| 336x336x445 | | 5x300x300x300 | | 3x144x144 | | 40x782x2346 | | | | | |
| 908969 | PCS 32 | 909027 | PCS 4 | 909134 | PCS 16 | 909248 | PCS 16 | 909253 | PCS 32 | 909256 | PCS 80 |
|  | |  | |  | |  | |  | |  | |
| Ø35 | | 5x140x202 | | M12x240 | | M12 | | Ø32/13.5 | | Ø16/8.4 | |
| 909506 | PCS 4 | 909633 | PCS 31 | 909850 | PCS 1 | 980100 | PCS 1192 | 980101 | PCS 208 | 980114 | PCS 4 |
|  | |  | |  | |  | |  | |  | |
| Ø3.5x13 | | M8 | | M8x25 | | Ø5x60 | | Ø4.5x70 | | Ø4x20 | |
| 980123 | PCS 736 | 980152 | PCS 160 | 980161 | PCS 4 | A10243 | PCS 1 | 702016 | PCS 1 | | PCS |
|  | |  | |  | |  | |  | | | |
| Ø7x60 | | Ø24/8.4x2 | | M10 | | | | | | | |
| | PCS | | PCS | | PCS | | PCS | | PCS | | PCS |

EN/AS Impact Area 16.6 m²

Grid size = 1000 mm

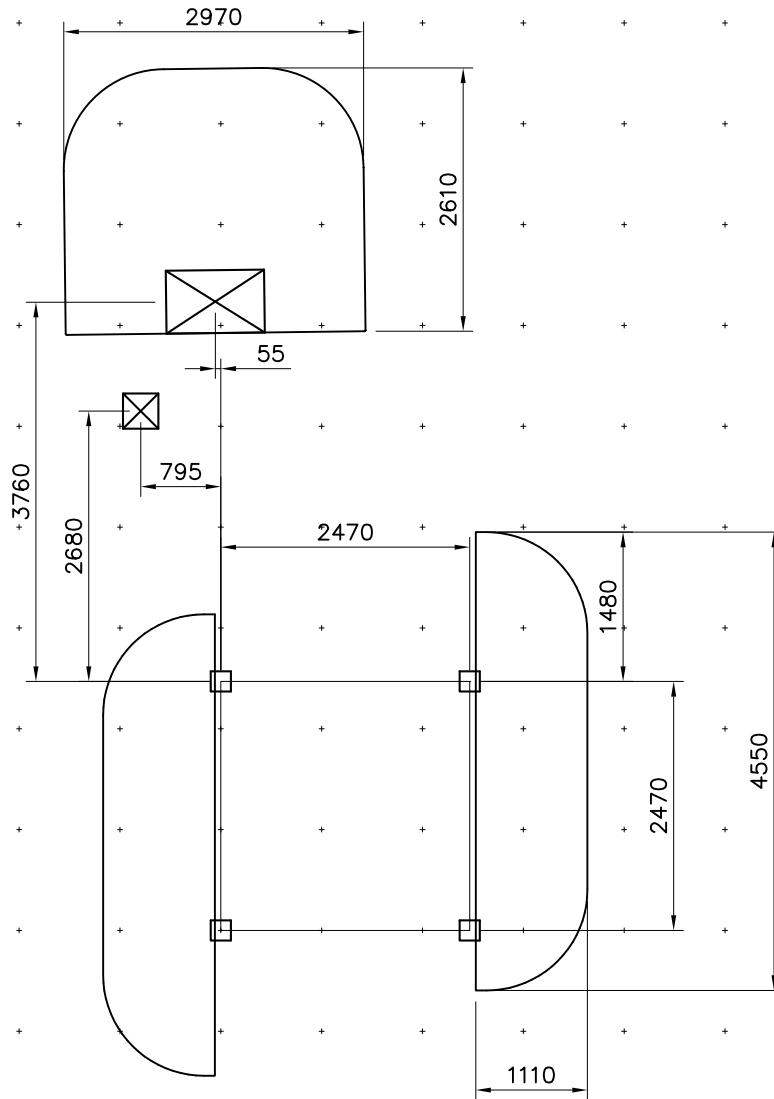
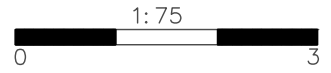

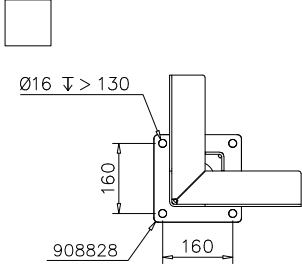
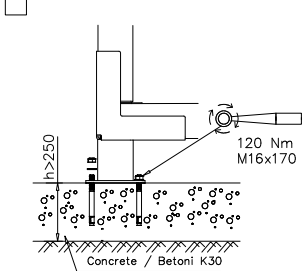
| | | |
|--|--|--|
| <p><input type="checkbox"/></p>  <p>Ø16 ∇ > 130 160 908828 160</p> | <p><input type="checkbox"/></p>  <p>h > 250 120 Nm M16x170 Concrete / Betoni K30</p> | |
| | | |
| | | |
| | | |

239022M FOUNDATION

2X REINFORCEMENT
STEELNET Ø $\frac{8}{150}$ A 500 HW
CONCRETE K30

1X REINFORCEMENT
STEELNET Ø $\frac{8}{150}$ A 500 HW
CONCRETE K30

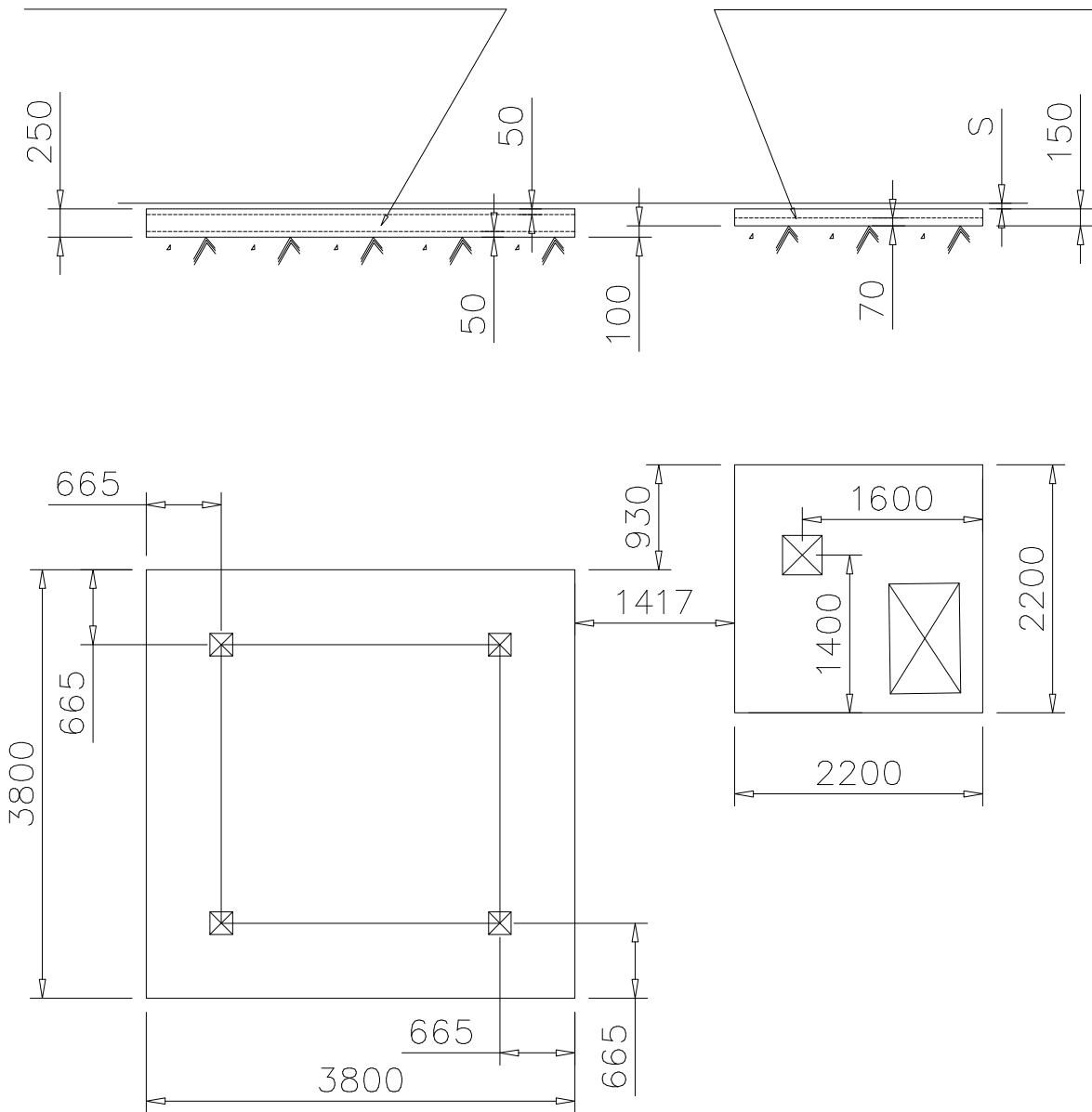

OPTION 2, METAL TUBE SLIDE

239022M FOUNDATION FOR METAL TUBE SLIDE

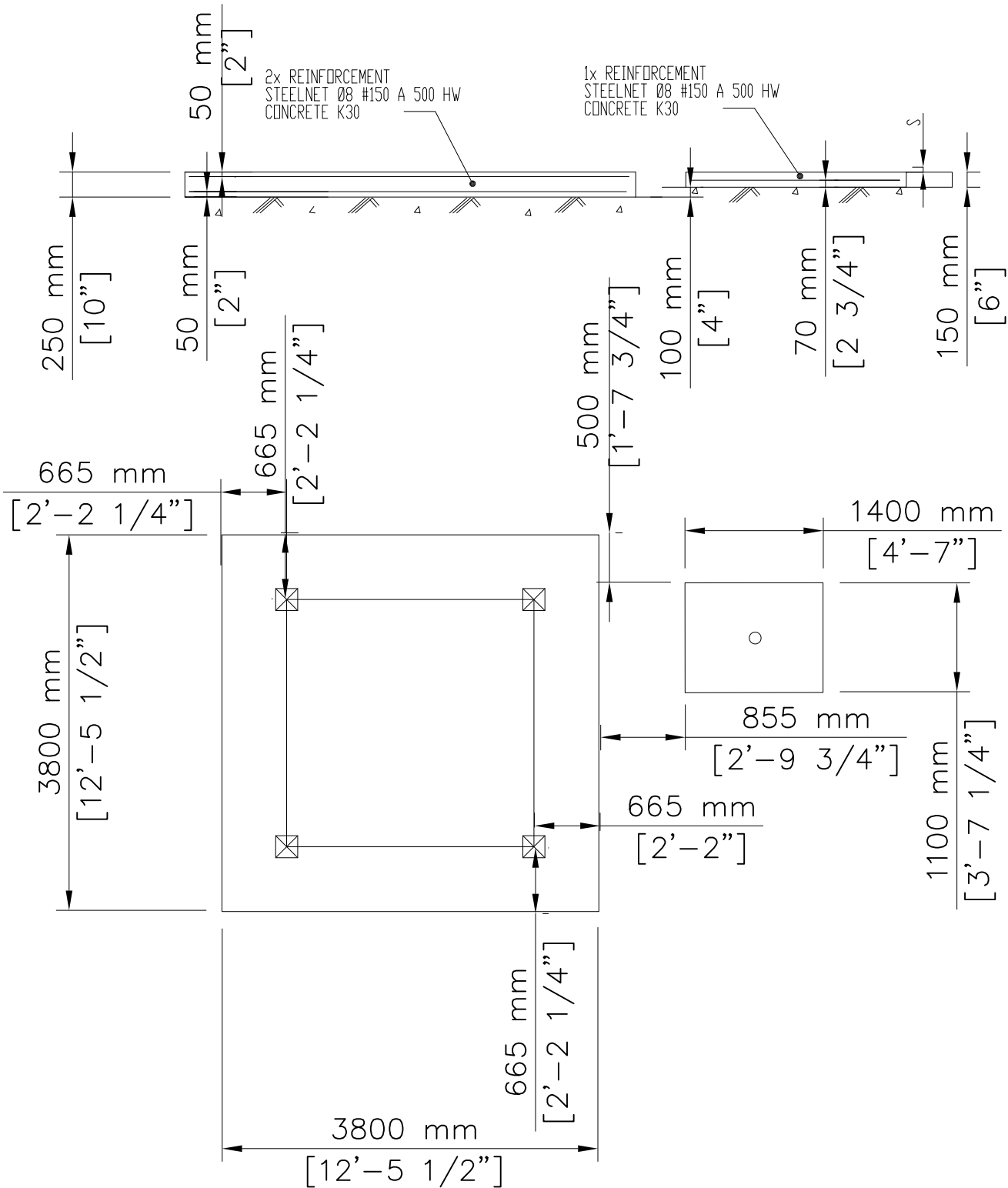

- EN/AS Impact Area 16.6 m²
- - - - Falling Space 20.2 m²
Max Falling Height 1170 mm

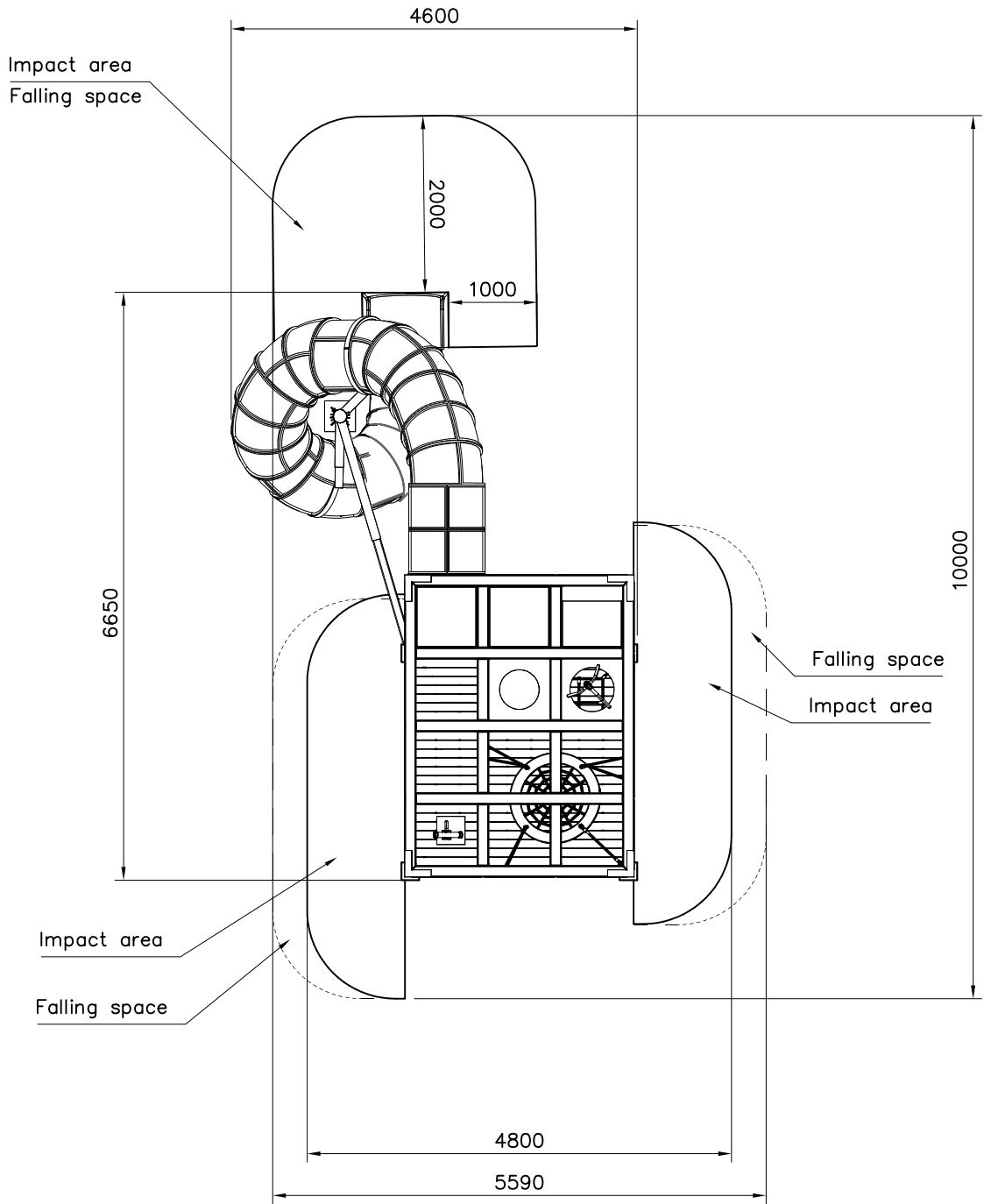
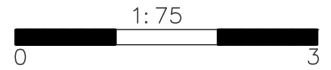

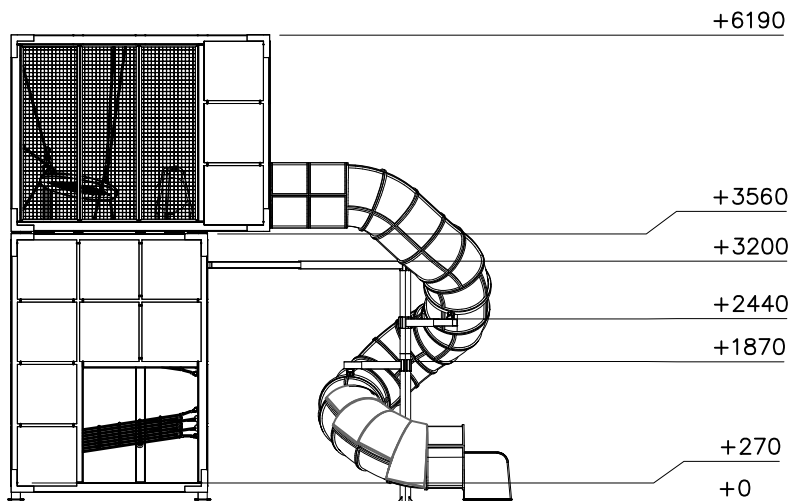
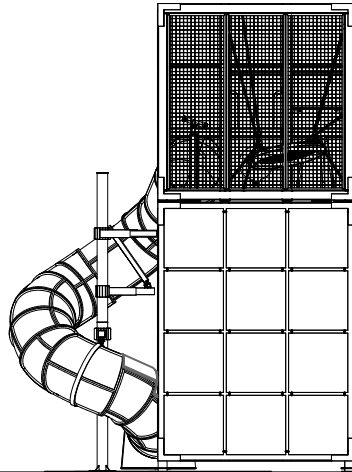

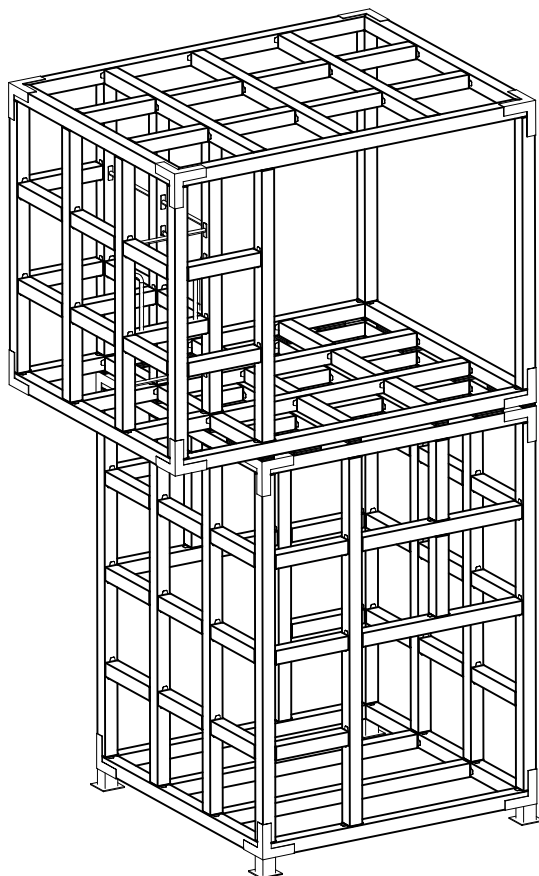
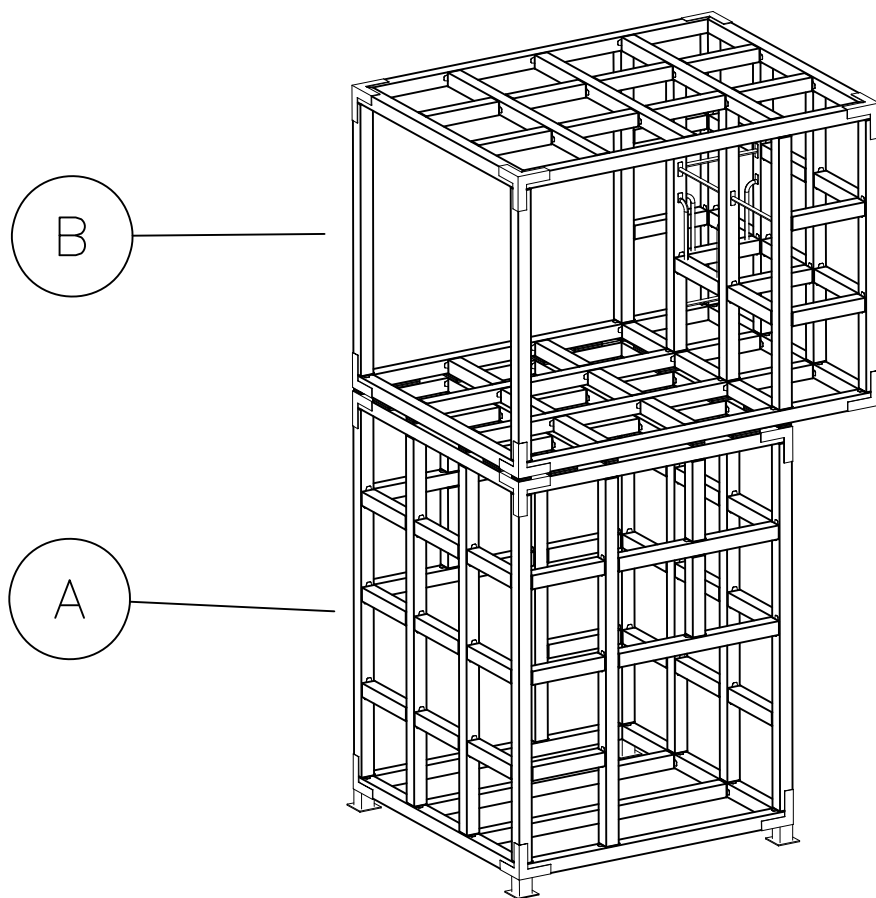

| | | | |
|---|--|---|---|
| <p>DET 1</p> <p>901302x8 980161x4 905115x4 902232x4 (M10x55) 905090x4</p> | <p>DET 2</p> <p>707304 900240x2 (8x70) 708351</p> | <p>DET 3</p> <p>905984 (Ø11,9x80) 708194 / 708202</p> | <p>DET 4</p> <p>900240 (Ø8x70) 708225 708226</p> |
| <p>DET 5</p> <p>980101 (4,5x70) 708223 708221</p> | <p>DET 6</p> <p>980101 (Ø4,5x70) 708221</p> | <p>DET 7</p> <p>708225 x4 900240 (Ø8x70) 3,4</p> | <p>DET 8</p> <p>708225 x4 900240 (Ø8x70) 20</p> |
| <p>DET 9</p> <p>908123x8 (7x60) 708228</p> | <p>DET 10</p> <p>980100x8 (5x60) 708229 / 708244</p> | <p>DET 11</p> <p>908123x8 (7x60) 708230</p> | <p>DET 12</p> <p>708234 900240 (8x70)</p> |
| <p>DET 13</p> <p>708235 980123x8 (7x60) 980152x8</p> | <p>DET 14</p> <p>708258 x2 980100 x4 (Ø5x60) DRILL THRU Ø13mm</p> | <p>DET 15</p> <p>DRILL THRU Ø13 Ø32 28 908969 909253 909134 (12x240) 909253 909248 908969 DRILL THRU Ø13 Ø32 28</p> | <p>DET 16</p> <p>After lifting the cube, remove the fastening eye and insert screws back 909027 Ø8x90</p> |
| <p>DET 17</p> <p>980100 708301 / 708302</p> | <p>DET 18</p> <p>708352 903093x4 (8x90) 901302x2 907727x2 (M10x40)</p> | <p>DET 19</p> <p>708352 980123x4 (7x60)</p> | <p>DET 20</p> <p>PRE-DRILL HOLE Ø5 30 907694 Ø7x60 (Ø80123)</p> |

| | | | |
|--|--|--|---|
| <p>DET 21</p> <p>Pre-drill hole. Ø6 ↓ 60</p> | <p>DET 22</p> <p>M10x80 (900727)</p> | <p>DET 23</p> <p>25</p> | <p>DET 24</p> <p>PRE-DRILL HOLE. Ø5 ↓ 30 Ø7x60 (980123)</p> |
| <p>DET 25</p> <p>908699 980100 x6 (Ø5x60)</p> | <p>DET 26</p> <p>900240 x2 (Ø8x70)</p> | <p>DET 27</p> <p>900240 x12 (Ø8x70) 908828</p> | <p>DET 28</p> <p>900240 x12 (Ø8x70) 908829</p> |
| <p>DET 29</p> <p>908835 980100 x6 (Ø5x60)</p> | <p>DET 30</p> <p>900240 x2 (Ø8x70)</p> | <p>DET 31</p> <p>908949 908123 (7x60)</p> | <p>DET 32</p> <p>908949 909633 905827 909256</p> |
| <p>DET 33</p> <p>909850 (M8x25) 901900x2 909633 908966 900342x2 (M8x16) 901902x2 901182 908967</p> | <p>DET 34</p> <p>908967 908966 901302x3 907727x3</p> | <p>DET 35</p> <p>263 182 705 263 182</p> | |

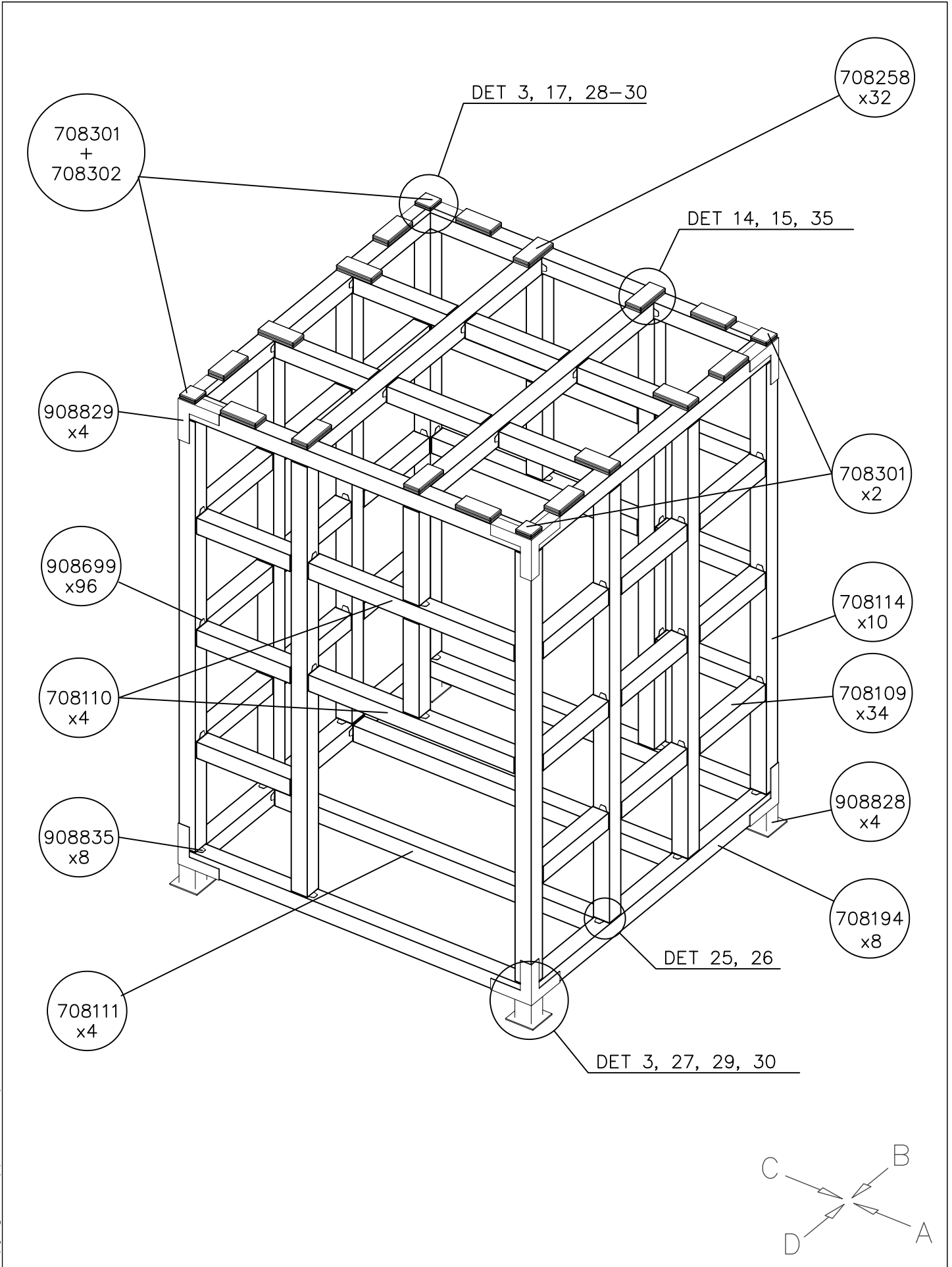

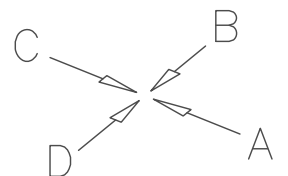
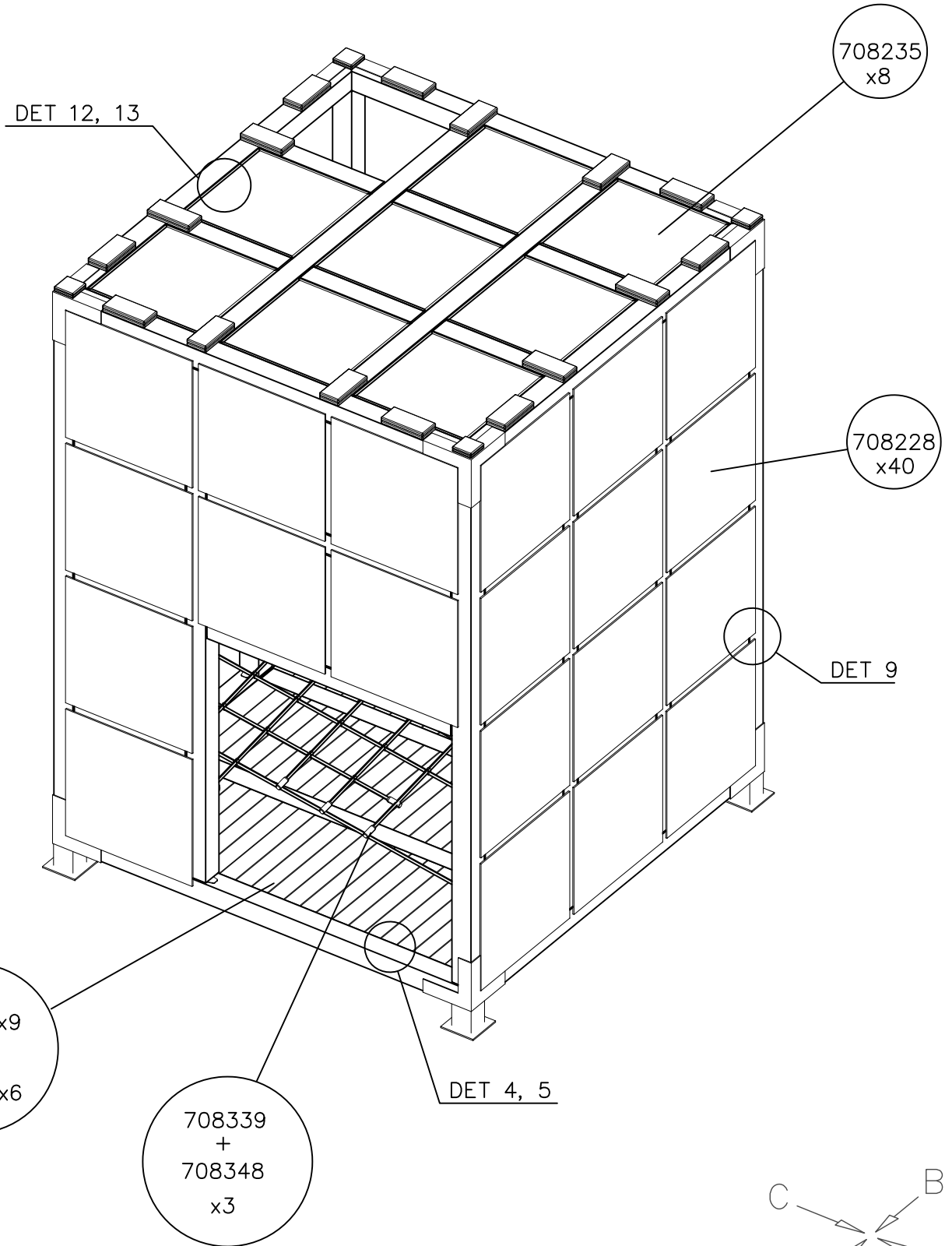

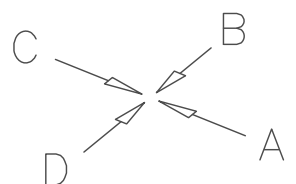
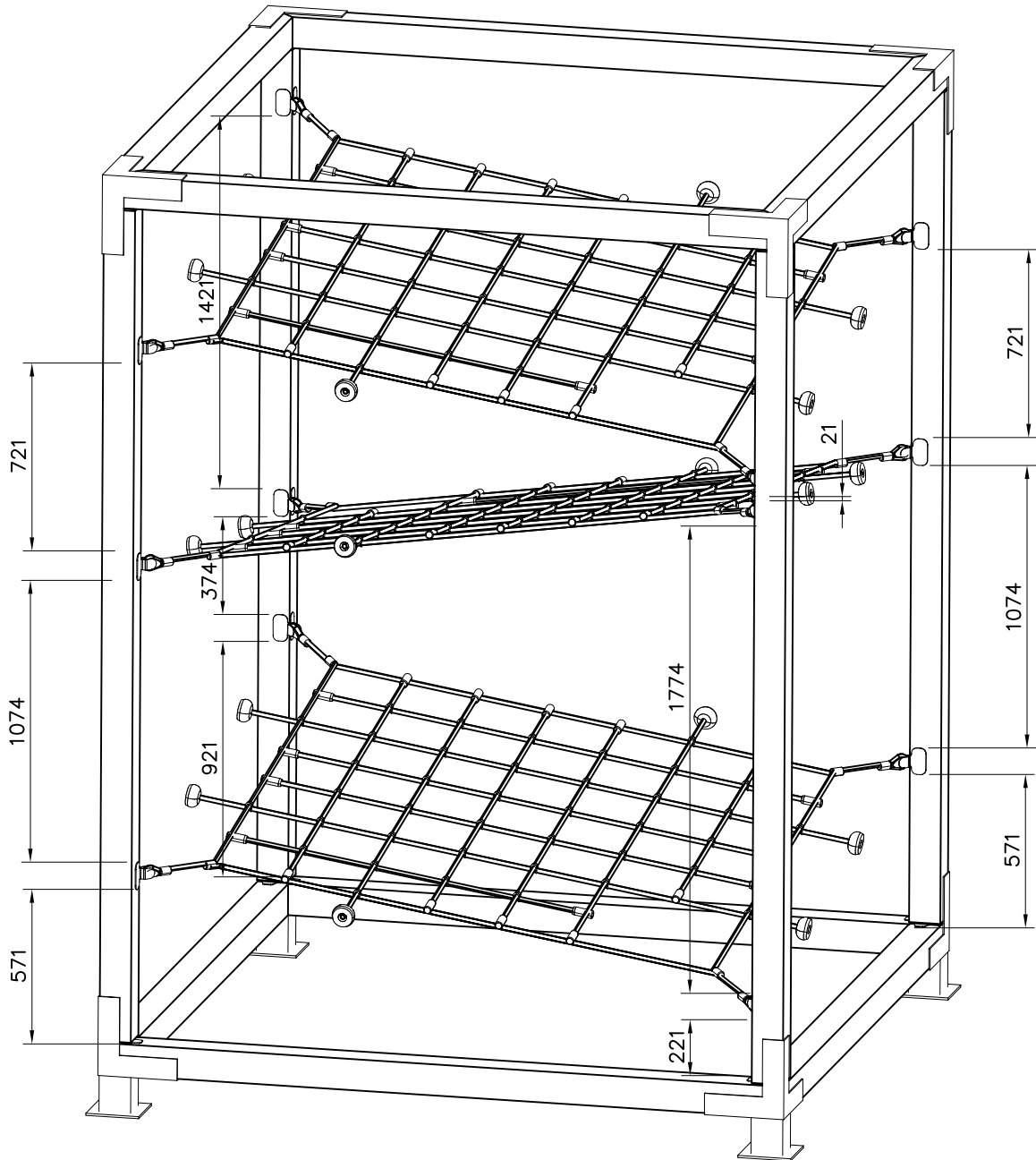

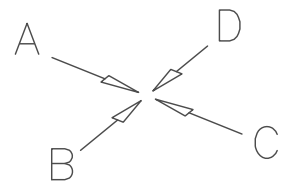
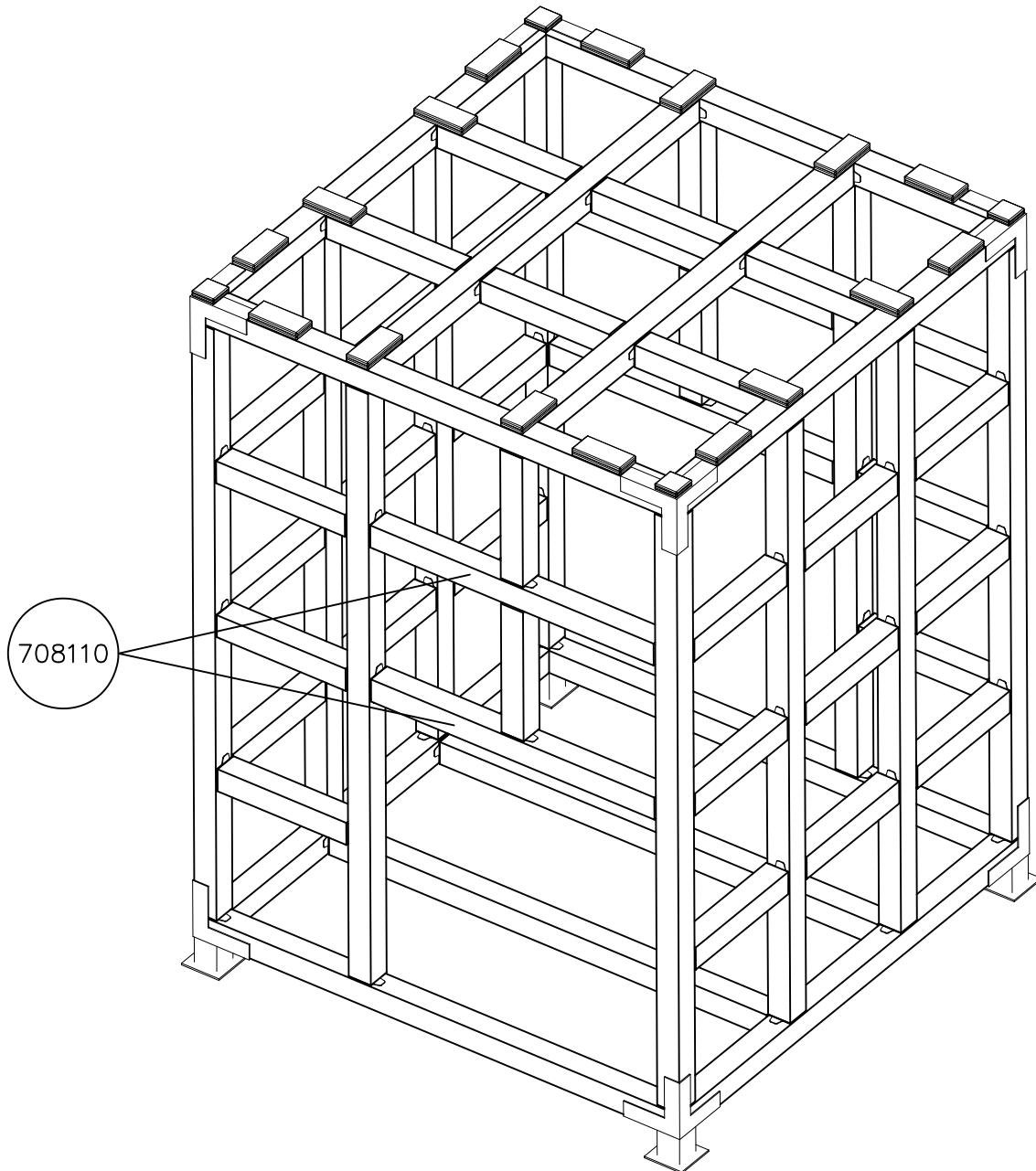

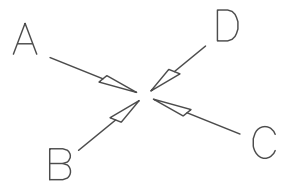
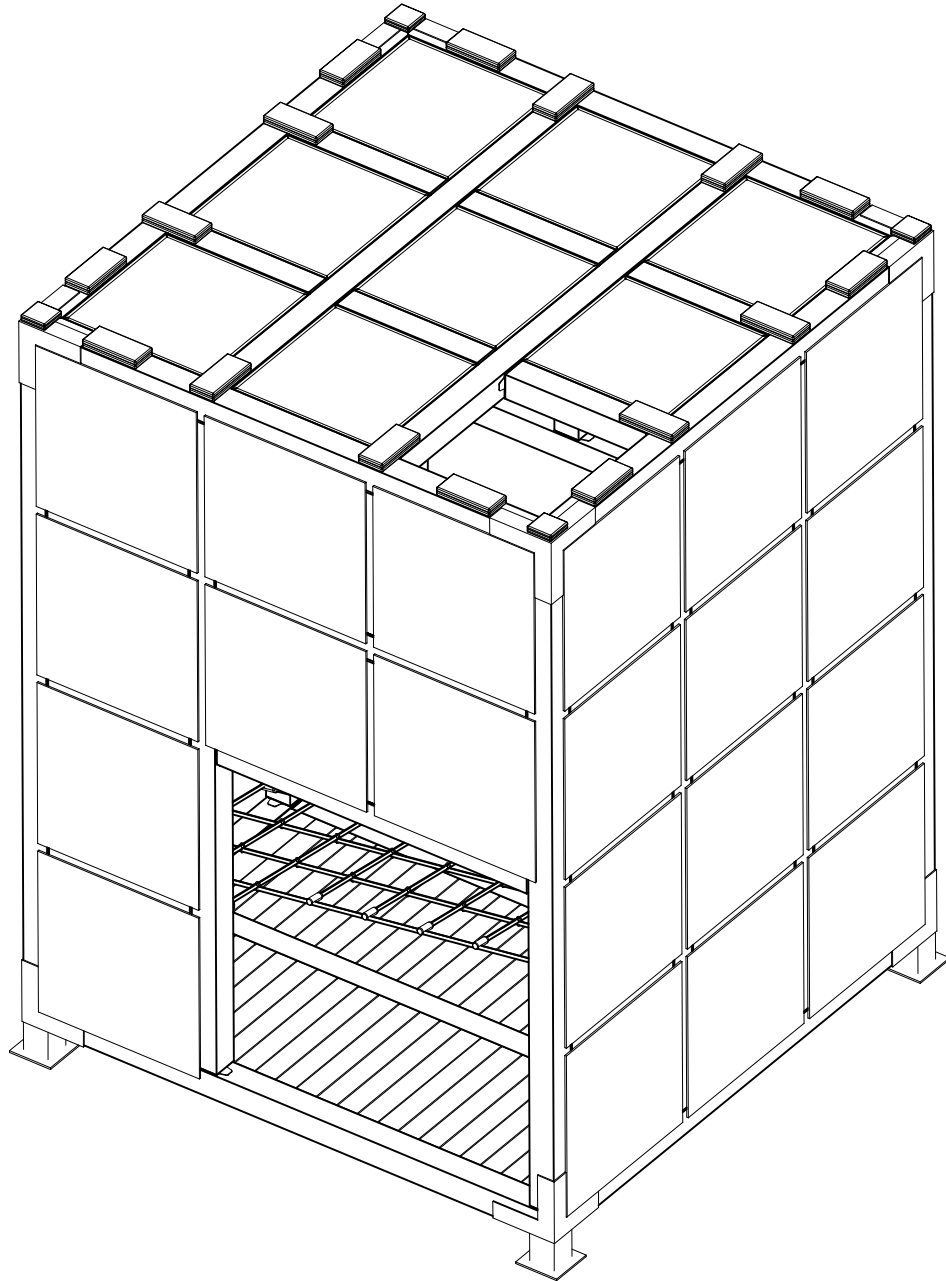

DATE: 13.3.2020

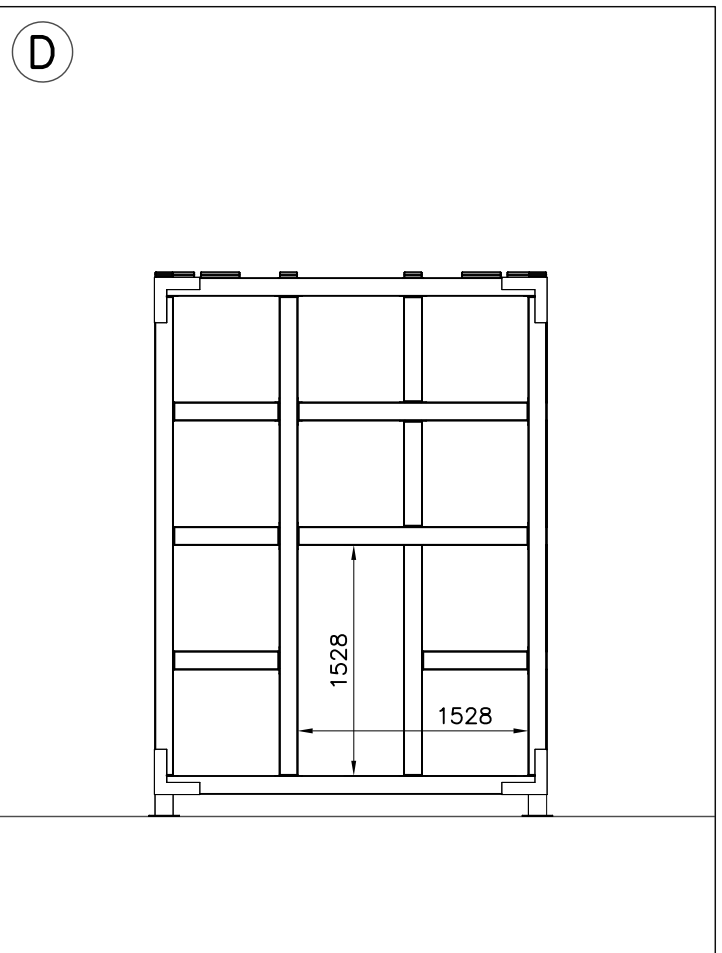
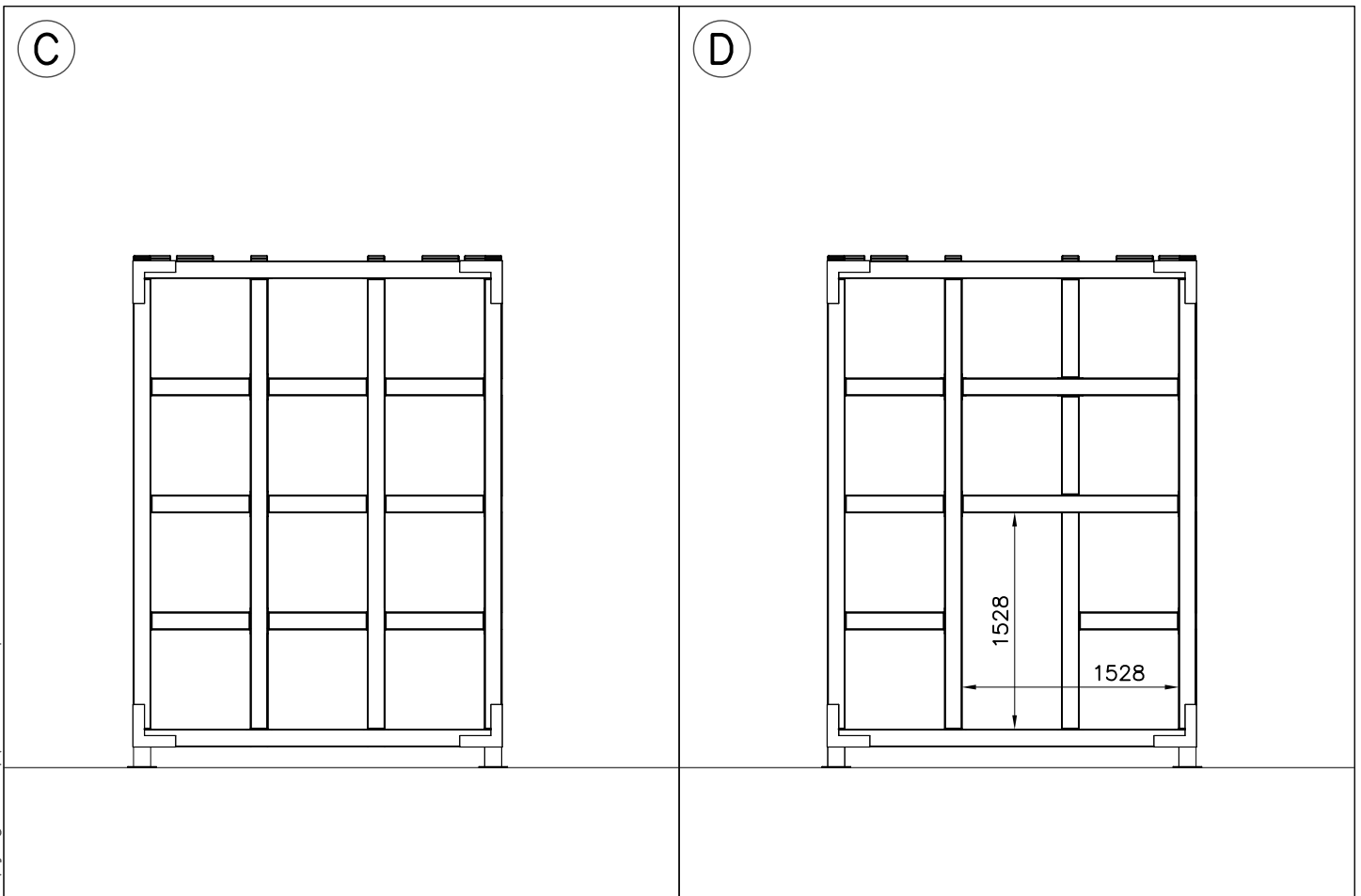
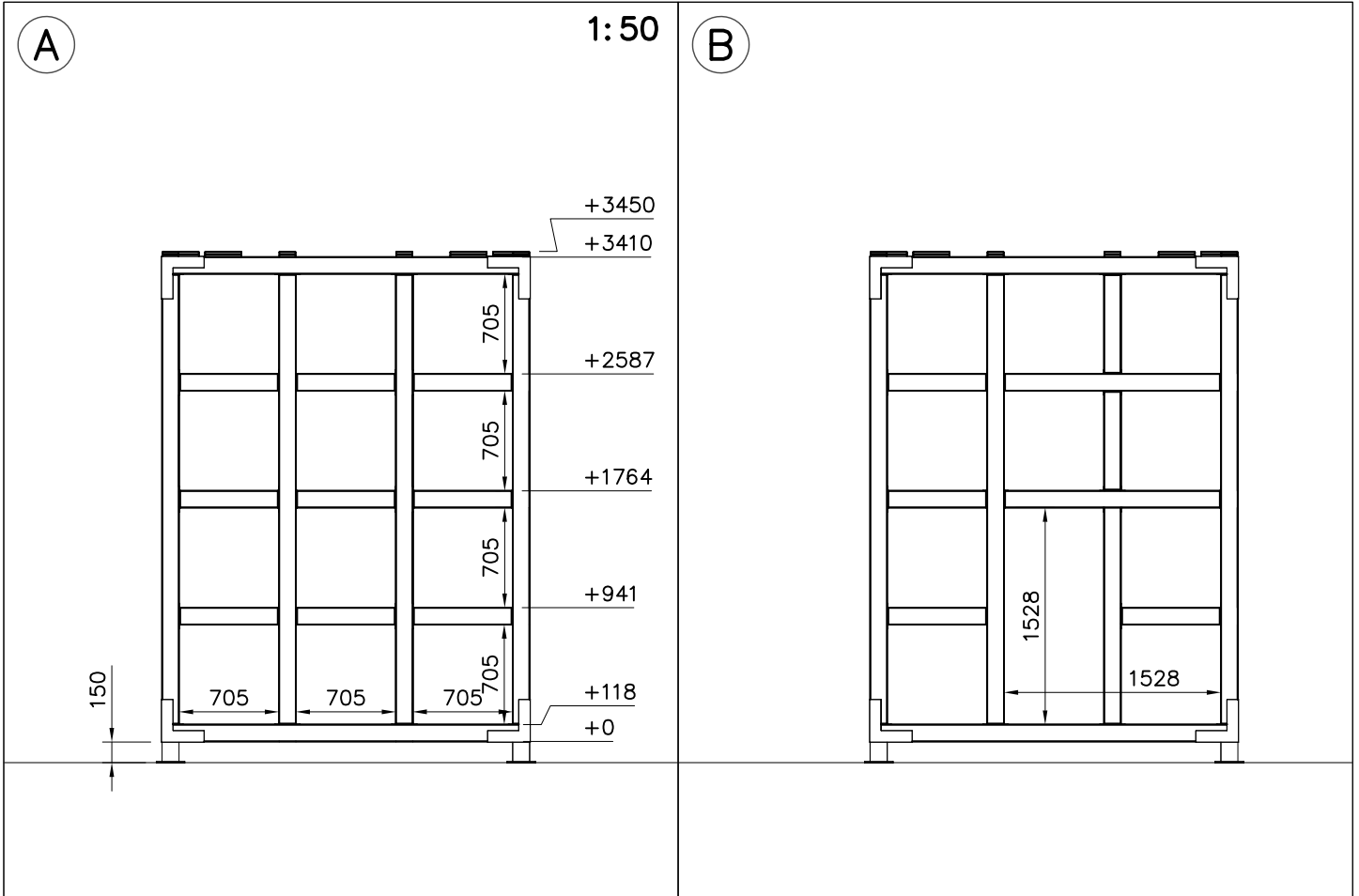

DET 16

907694
x4

908699
x84

708111
x13

907701
x6

908835
x8

708202
x4

708109
x31

708114

908829
x8

708194
x4

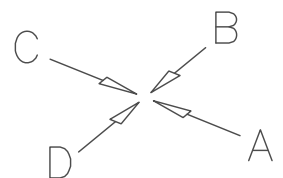

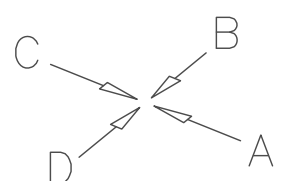
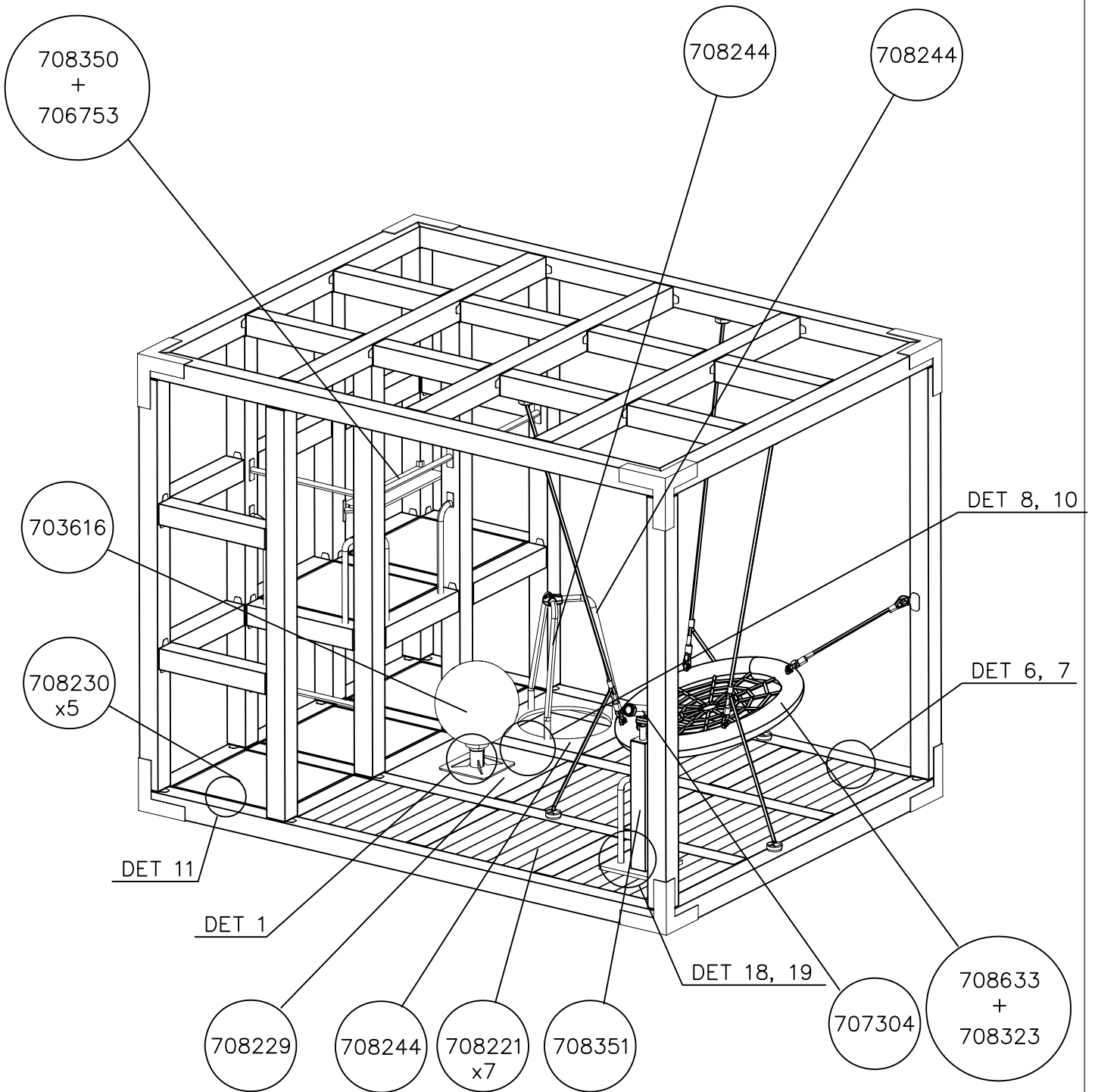

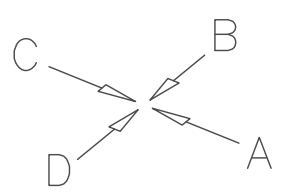
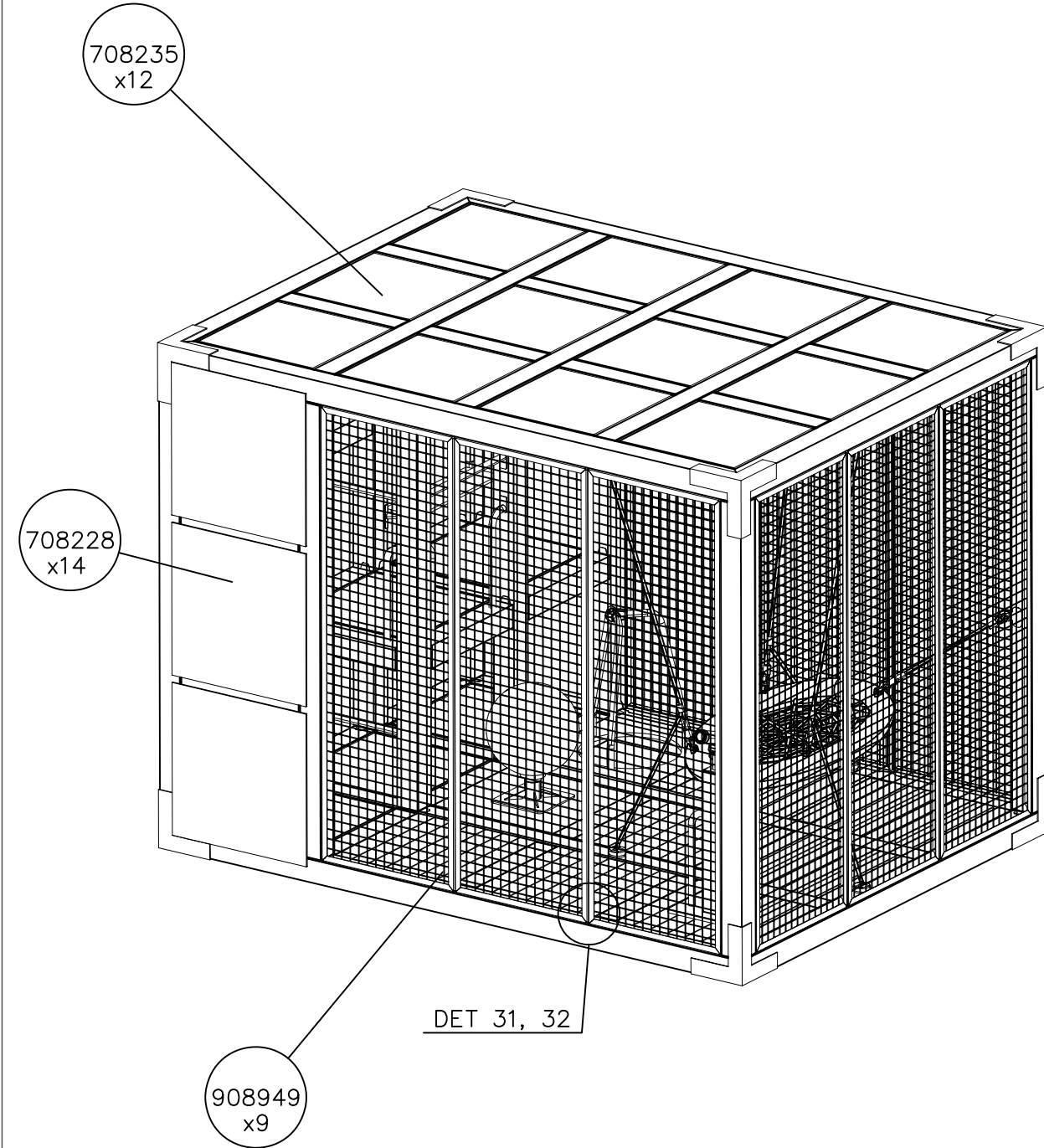

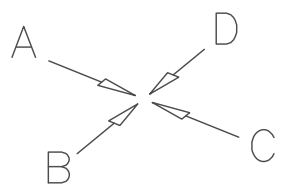
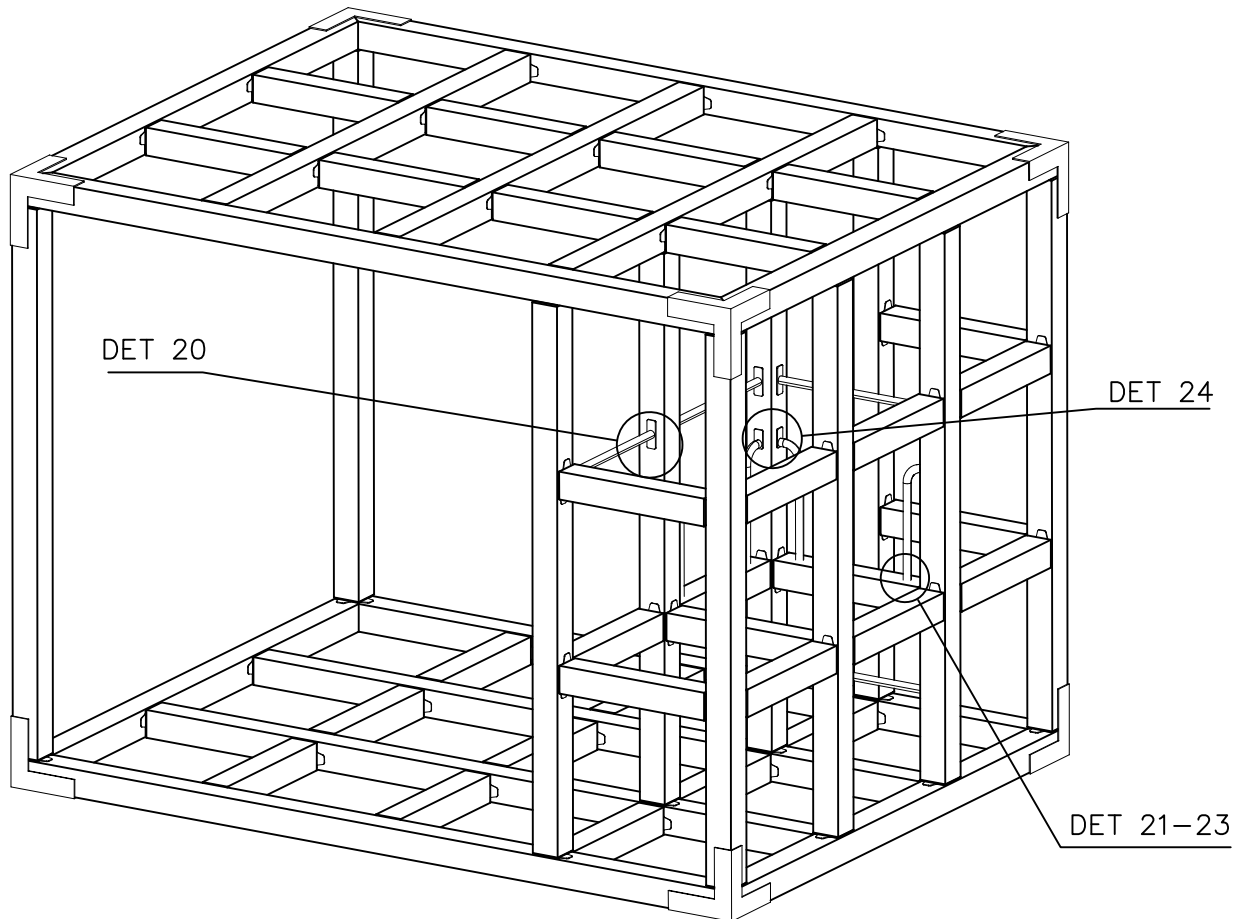

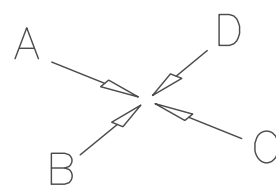
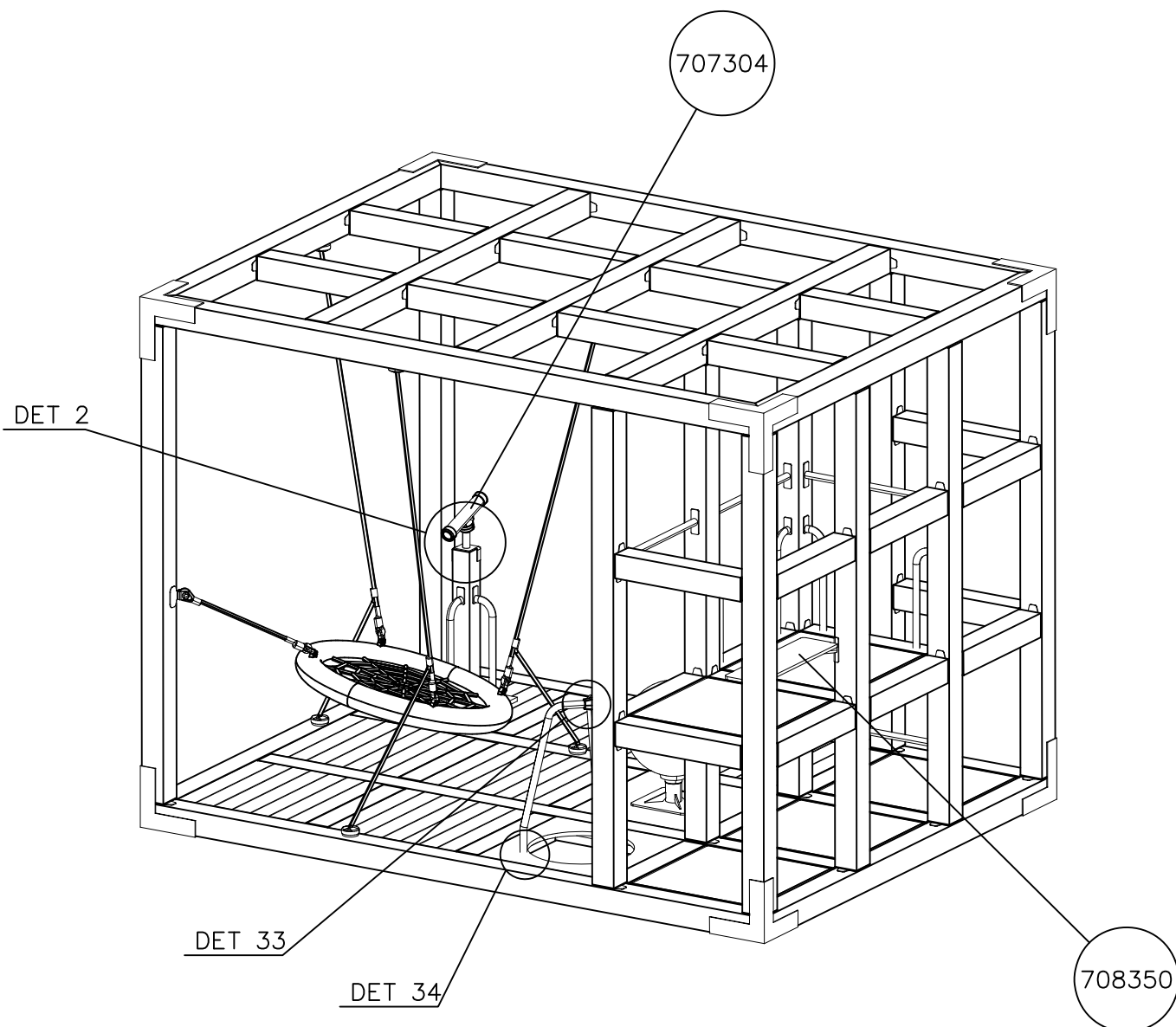

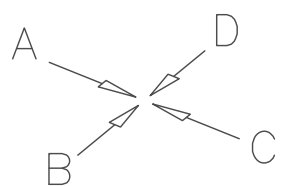
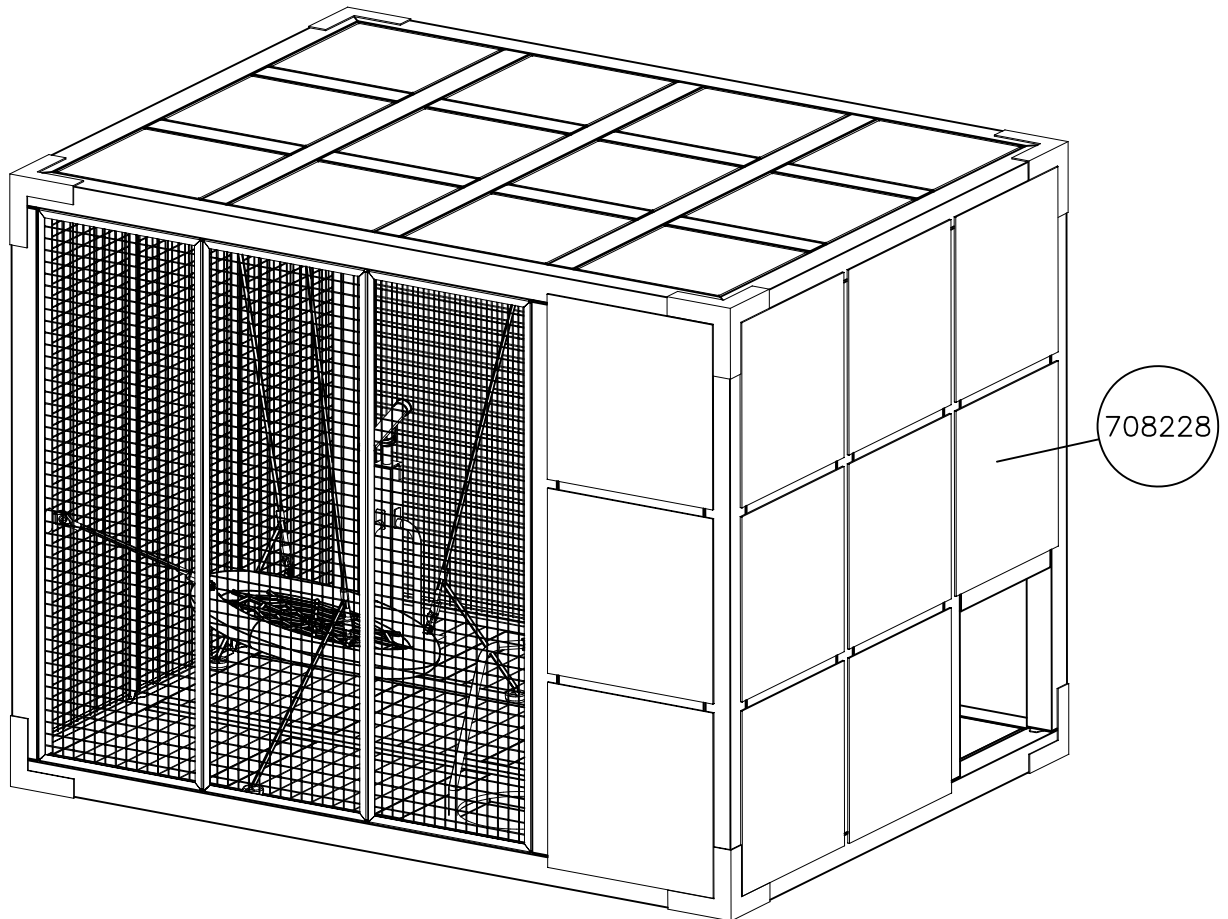

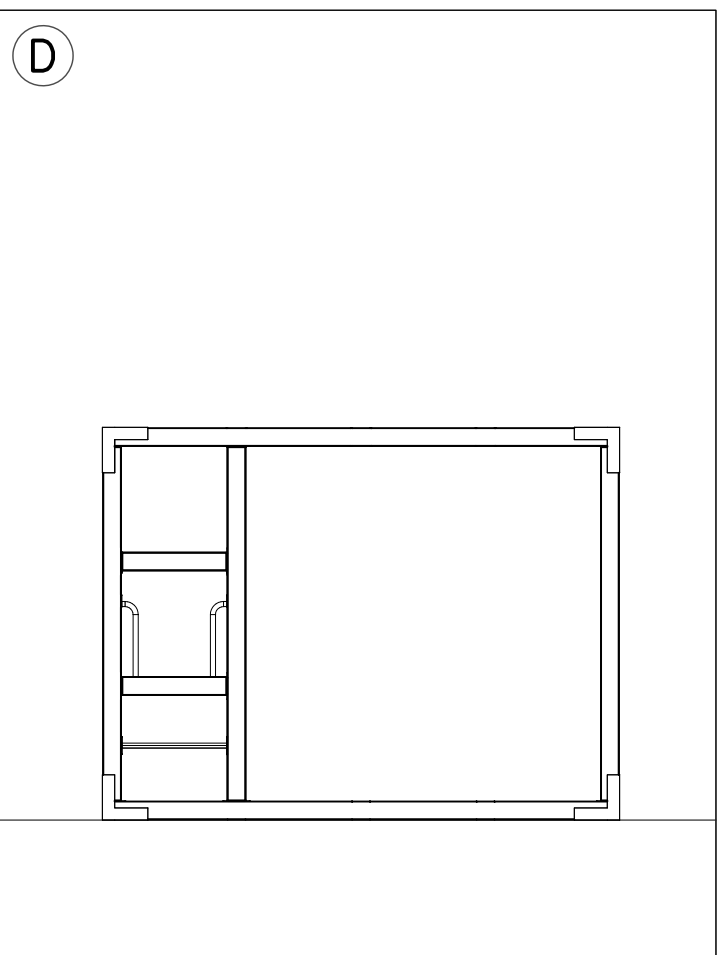
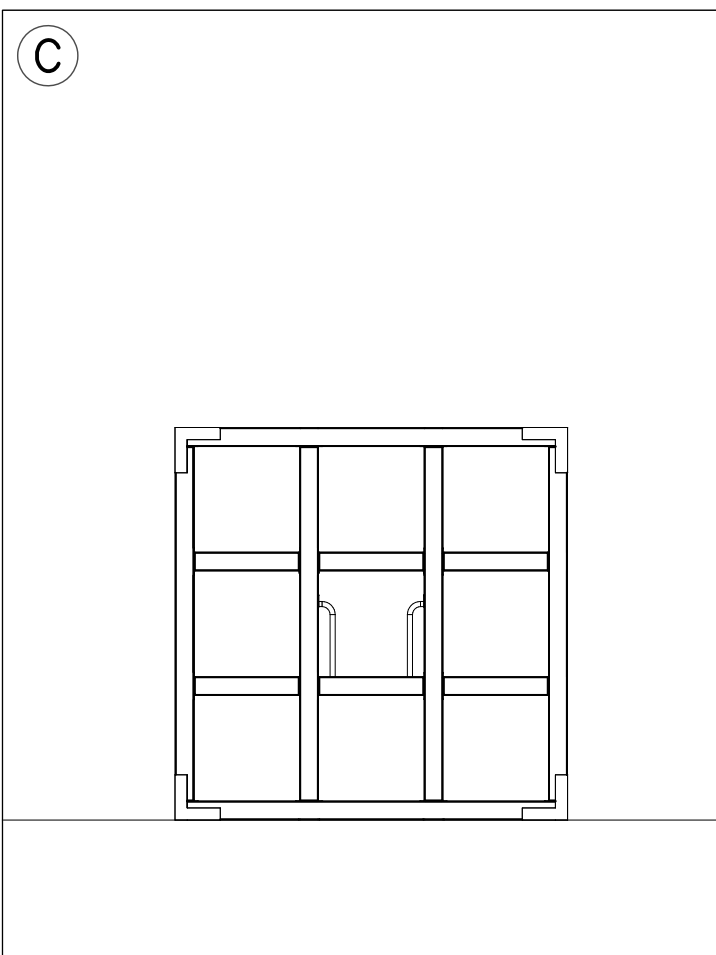
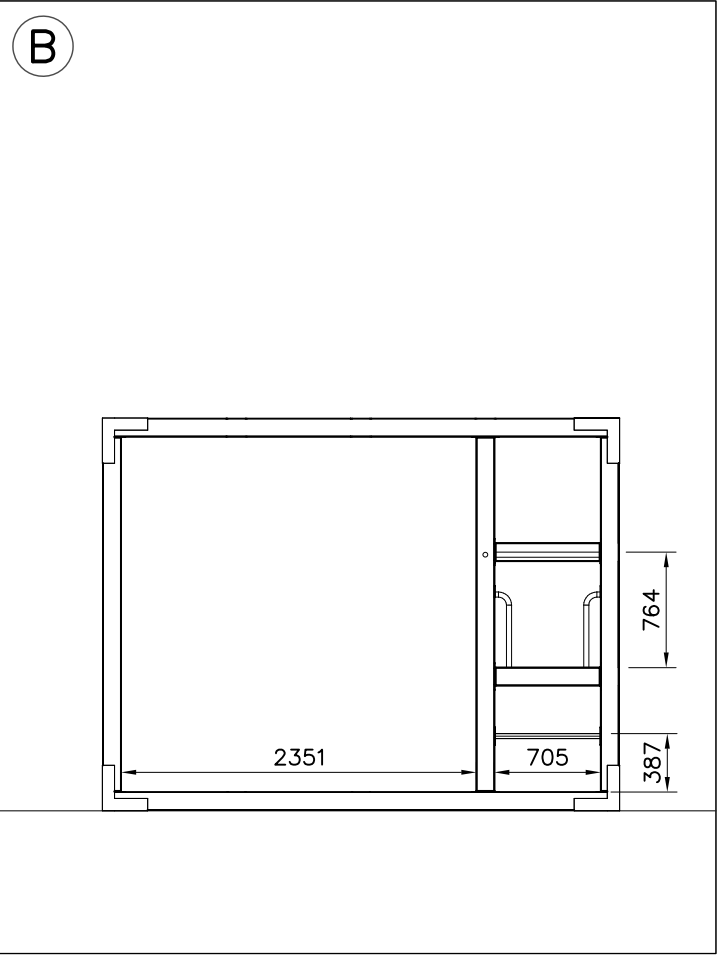
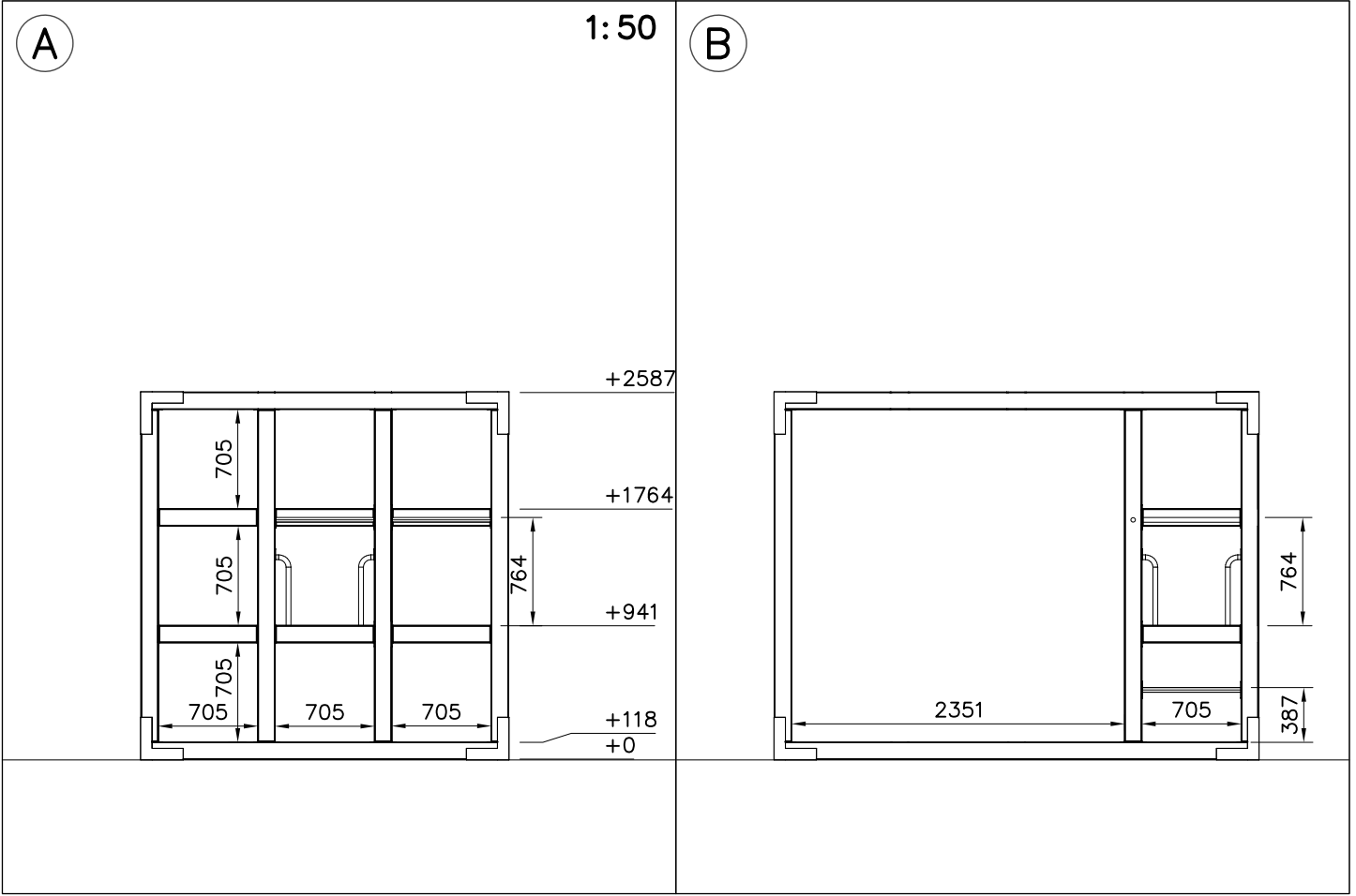

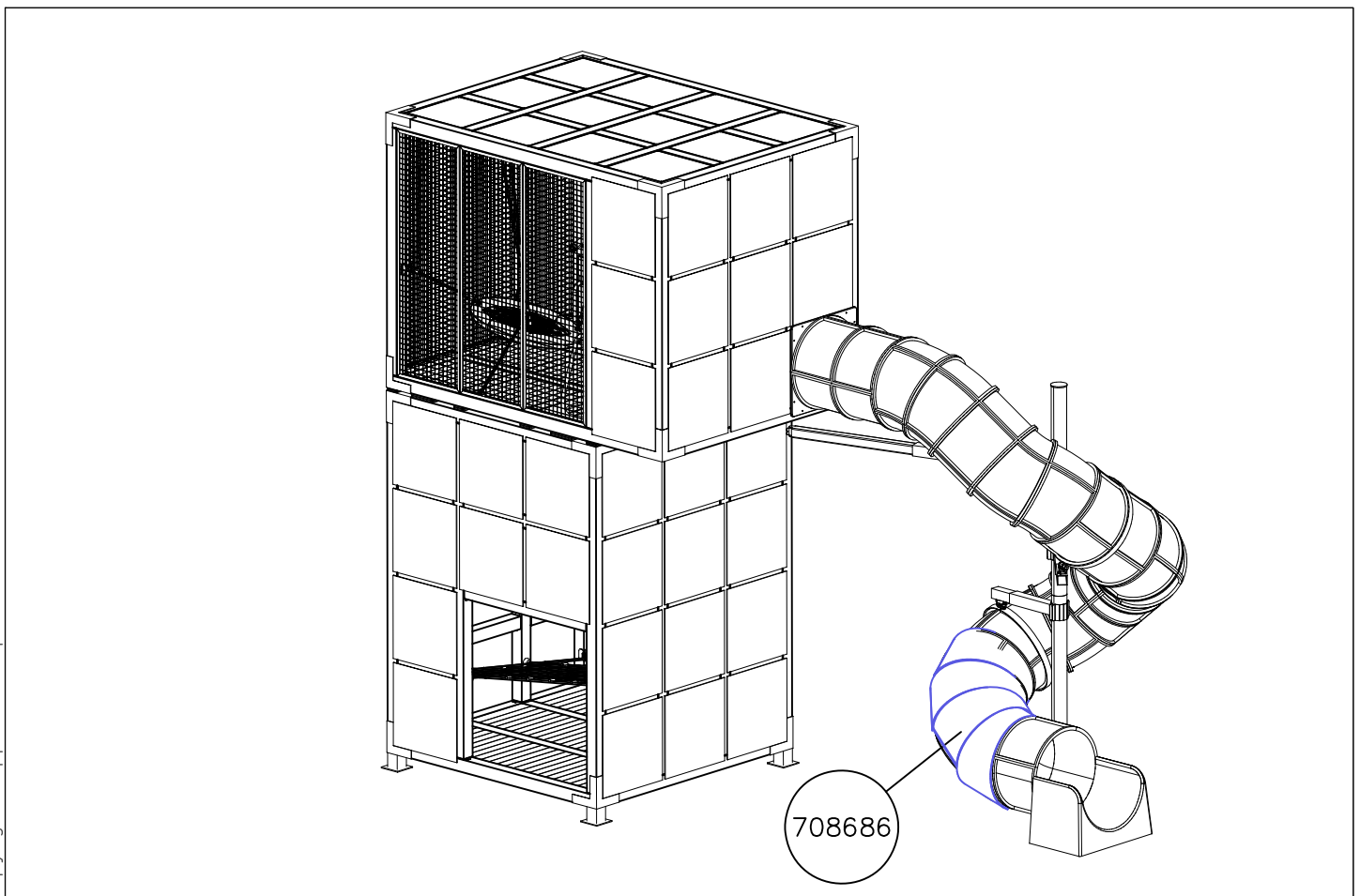
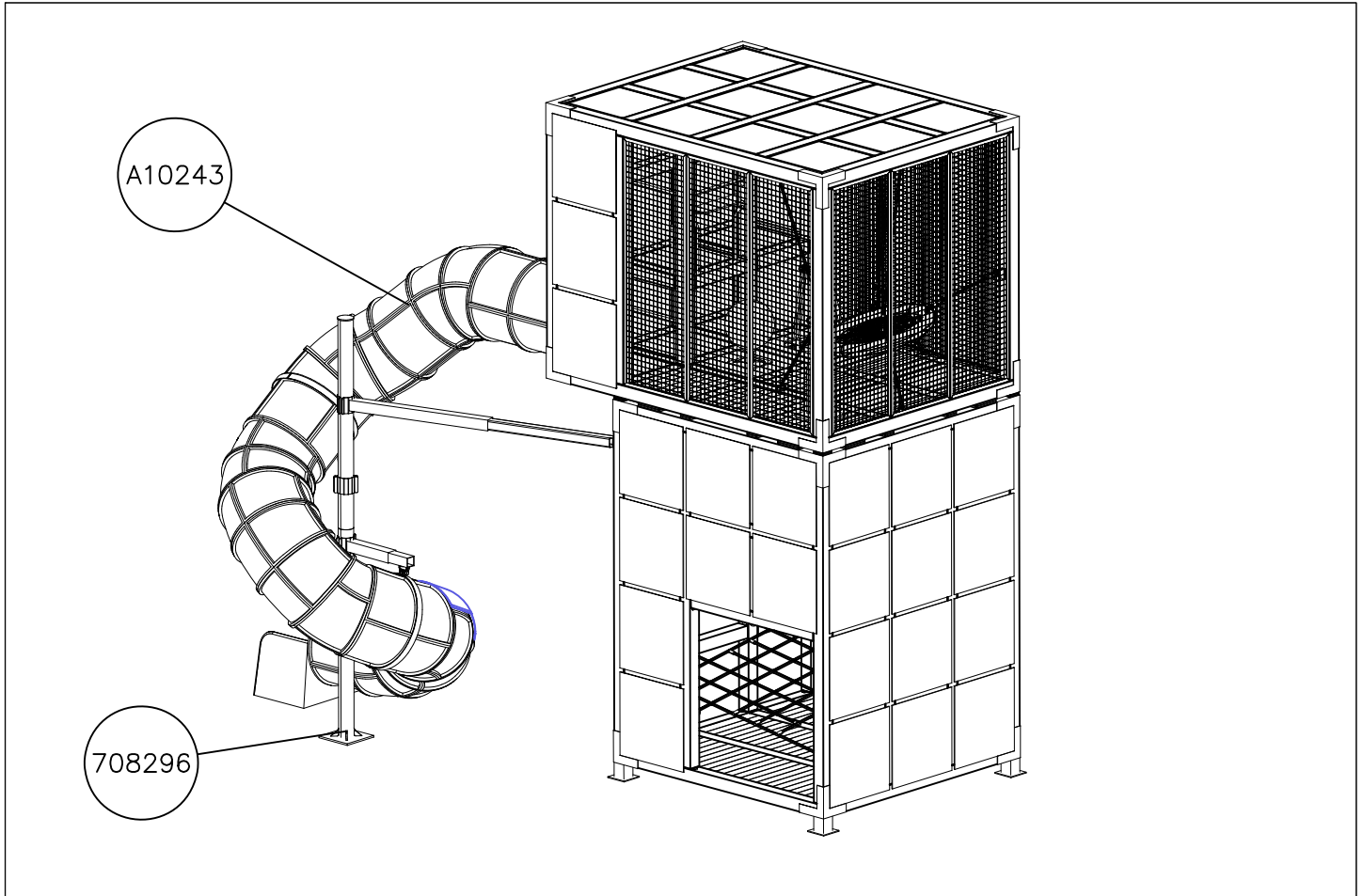

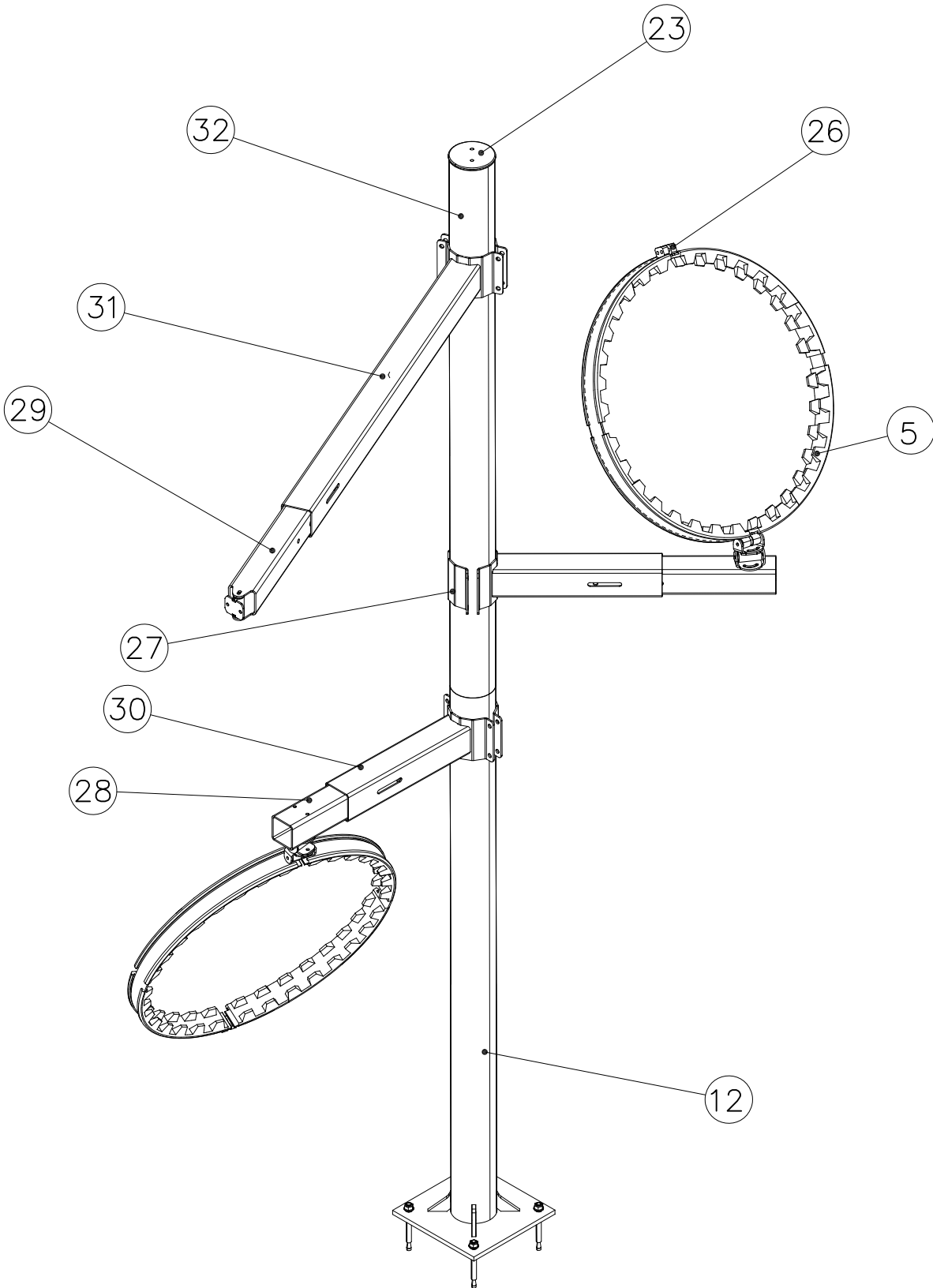

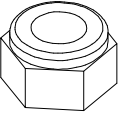

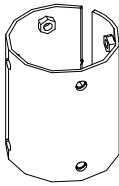
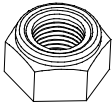
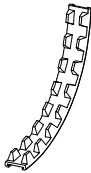

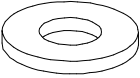

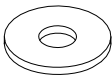
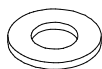
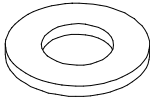

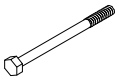
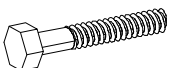
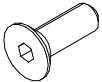
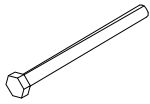
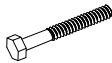
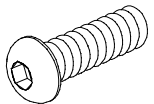
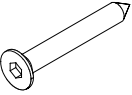

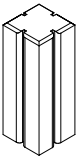
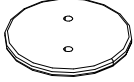
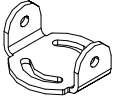
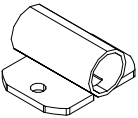

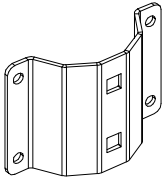
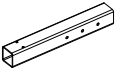
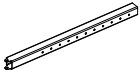
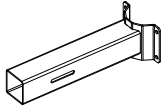
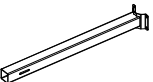

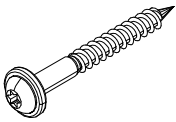

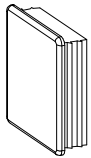
| | | | | | |
|--|--|--|--|--|---|
| ① 909248  M12 PCS 15 | ② 909633  M8 PCS 4 | ③ 909071  PCS 1 | ④ 980150  M8 PCS 13 | ⑤ 905864  PCS 8 | ⑥ 909523  Ø32/13.5/2 PCS 6 |
| ⑦ 980154  Ø24/13 PCS 24 | ⑧ 980152  Ø24/8.4x2 PCS 4 | ⑨ 905051  Ø24/8.4 PCS 18 | ⑩ 980151  Ø16/8.4 PCS 8 | ⑪ 909256  Ø16/8.4x1.6 PCS 4 | ⑫ 909068  PCS 1 |
| ⑬ 909130  M12x120 PCS 3 | ⑭ 909142  M12x70 PCS 12 | ⑮ 900958  M10x30 PCS 8 | ⑯ 906498  M8x110 PCS 9 | ⑰ 909097  M8x60 PCS 4 | ⑱ 905827  M8x20 PCS 4 |
| ⑲ 906630  8x60 PCS 4 | ⑳ 980123  7x60 PCS 2 | ㉑ 908057  Ø32/29-L5/30 PCS 10 | ㉒ 707632  PCS 1 | ㉓ 708291  Ø145 PCS 1 | ㉔ 909053  PCS 4 |
| ㉕ 909057  PCS 3 | ㉖ 909067  PCS 4 | ㉗ 909069  PCS 3 | ㉘ 909318  PCS 2 | ㉙ 909326  PCS 1 | ㉚ 909282  PCS 2 |
| ㉛ 909317  PCS 1 | ㉜ 909278  PCS 1 | ㉝ 900240  8x70 PCS 2 | ㉞ 904450  M16x170 PCS 4 | ㉟ 910405  90x90x30 PCS 2 | PCS |
| PCS | PCS | PCS | PCS | PCS | PCS |

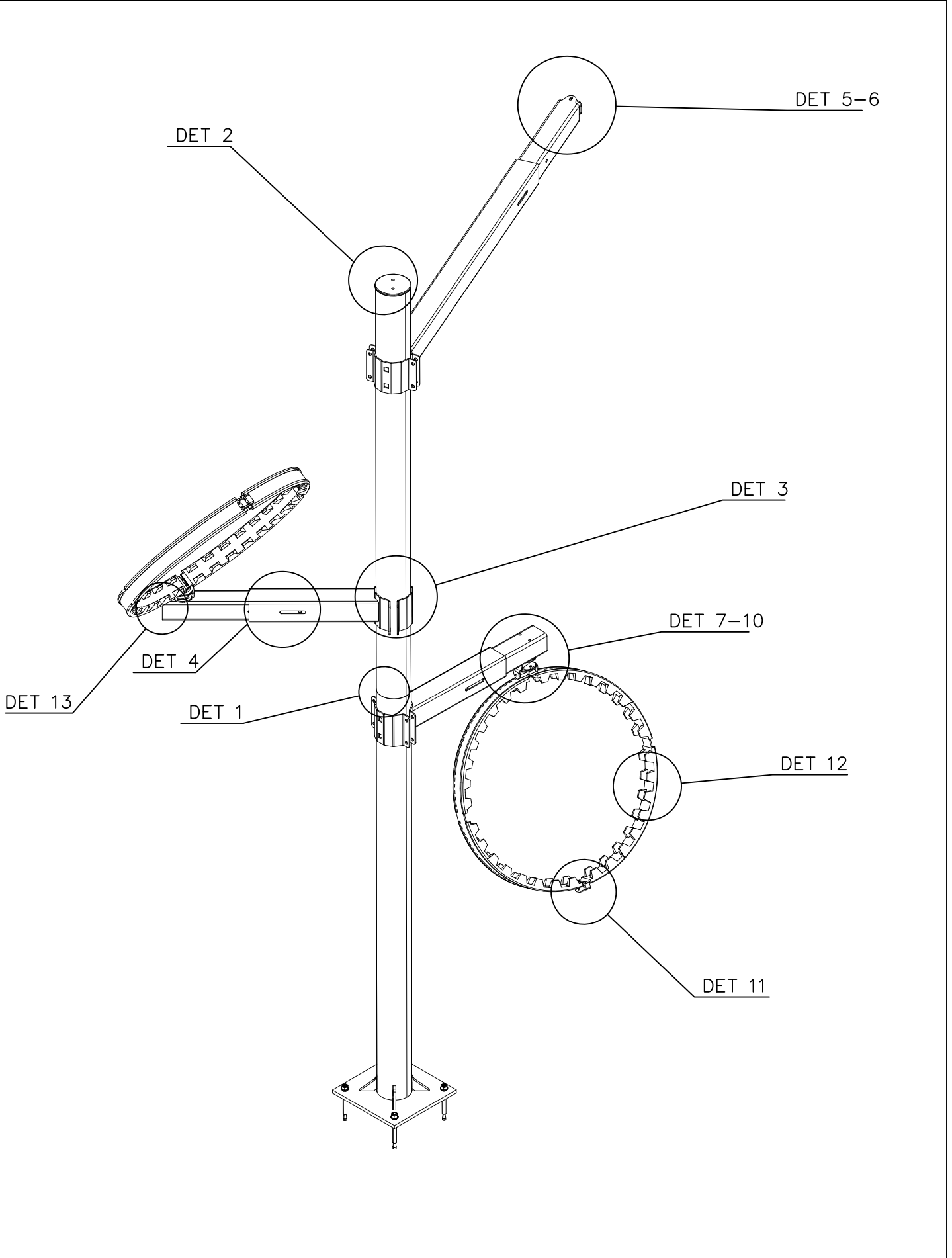

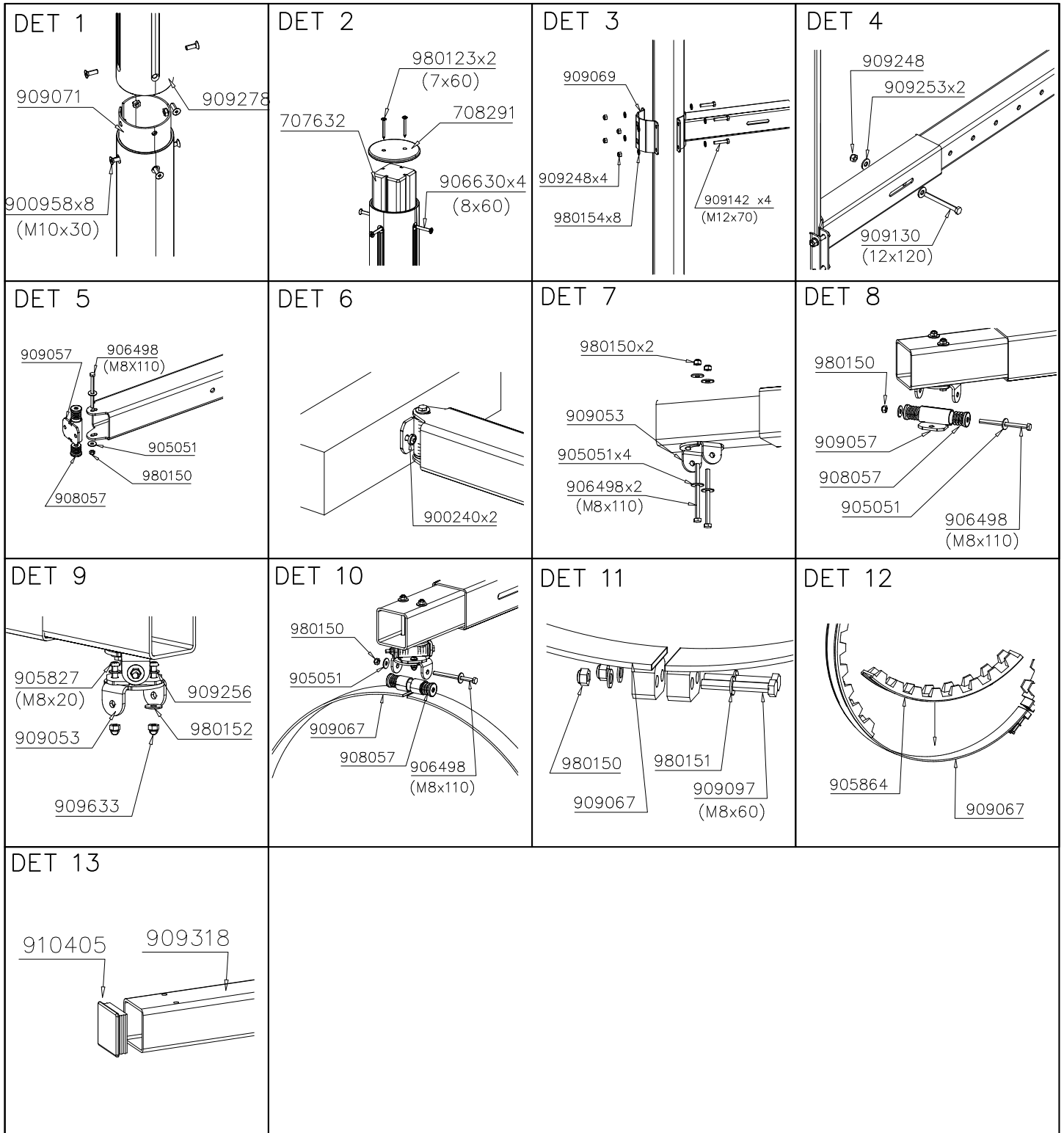

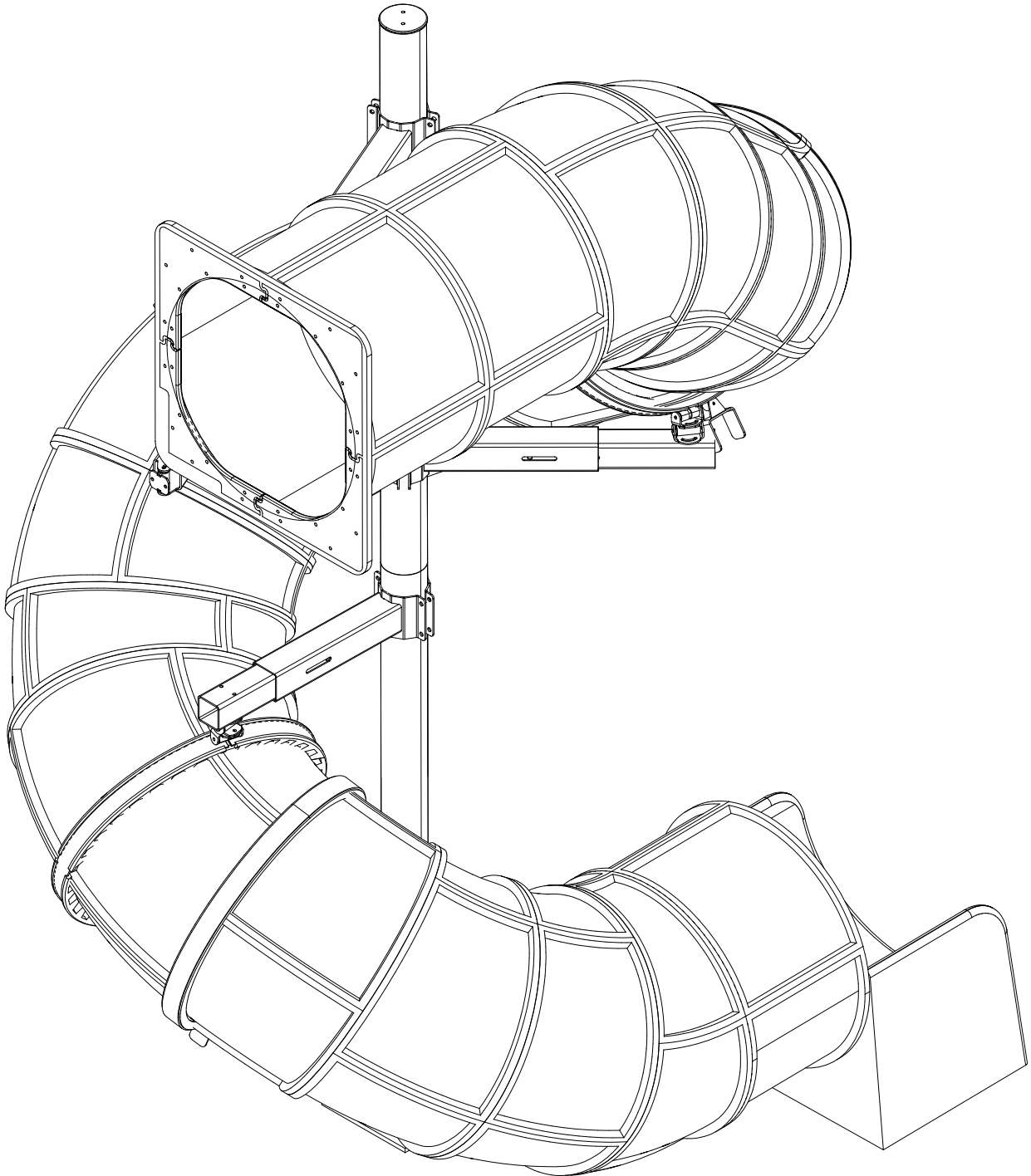

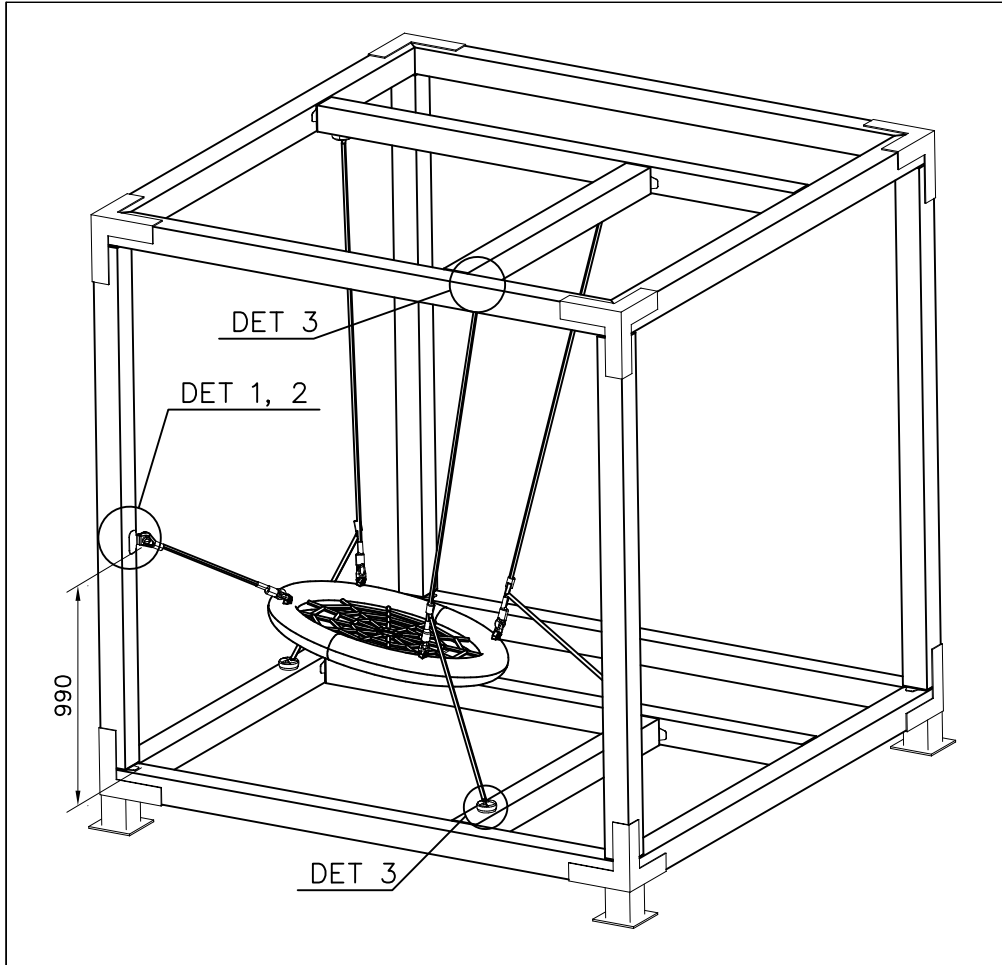

| | | | |
|----------|-----|----------|-----|
| ① 929561 | PCS | ② 903093 | PCS |
| | 2 | | 12 |
| | | Ø8x90 | |
| ③ 900240 | PCS | ④ 905083 | PCS |
| | 4 | | 2 |
| Ø8x70 | | Ø32 | |
| ⑤ 909568 | PCS | ⑥ 980151 | PCS |
| | 1 | | 2 |
| M8x55 | | Ø16/8.4 | |
| ⑦ 980150 | PCS | ⑧ 905112 | PCS |
| | 1 | | 2 |
| M8 | | Ø22 | |
| | PCS | | PCS |
| | | | |
| | | | |
| ○ 708633 | PCS | | PCS |
| | | | |
| | PCS | | PCS |
| | | | |
| | PCS | | PCS |
| | | | |

U=upper fastener
L=lower fastener

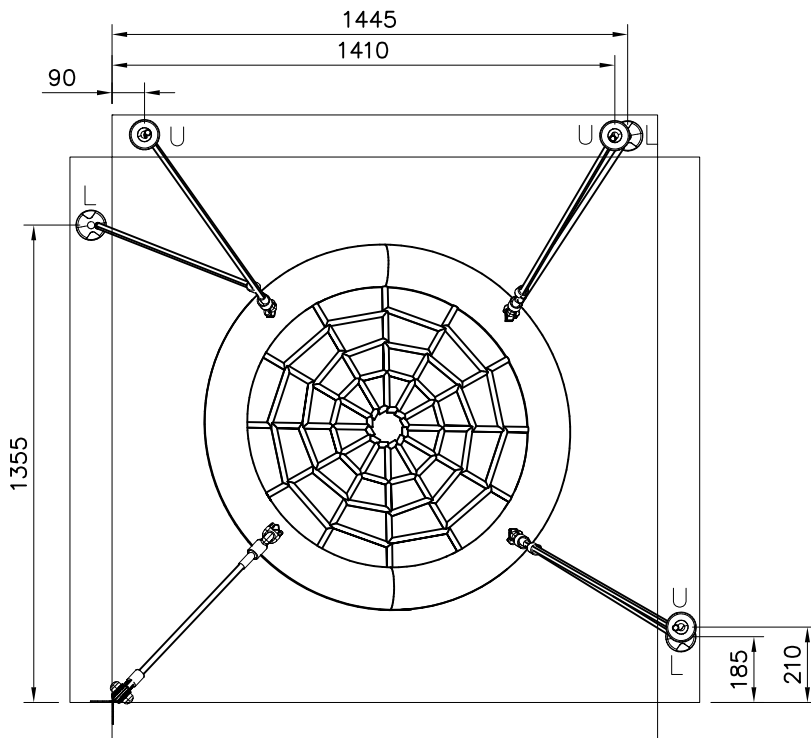

DET 1

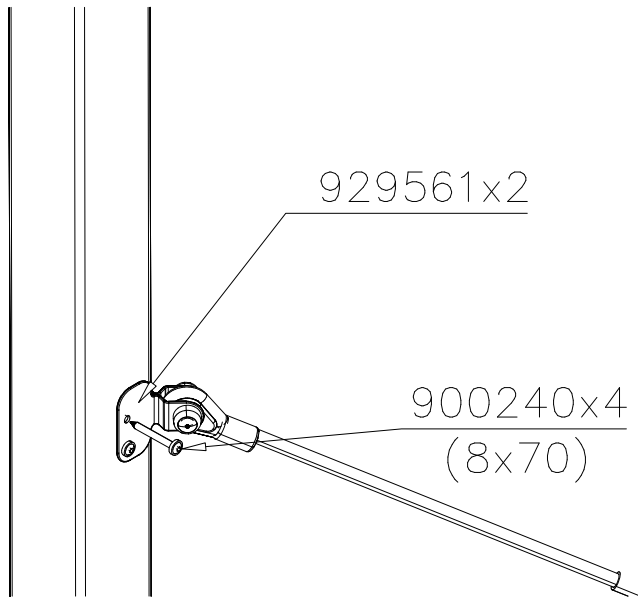

DET 2

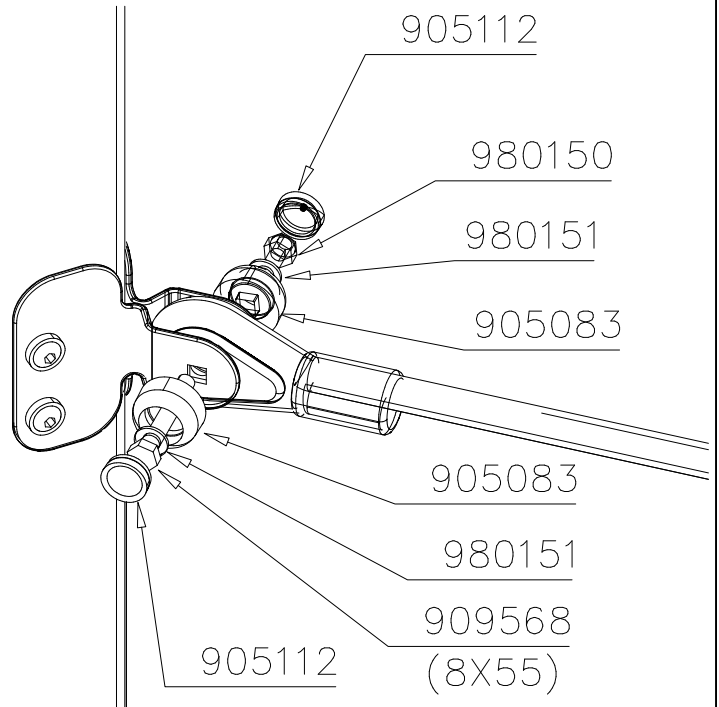

DET 3

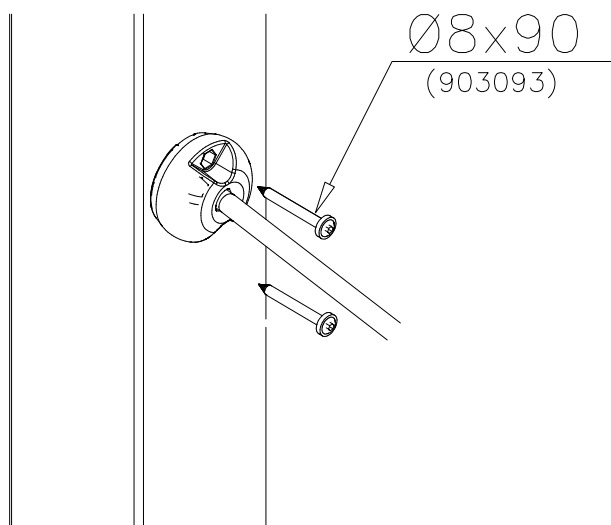

LAPPSET®

CUBIC

708348

DATE: 17.8.2022

1(3)

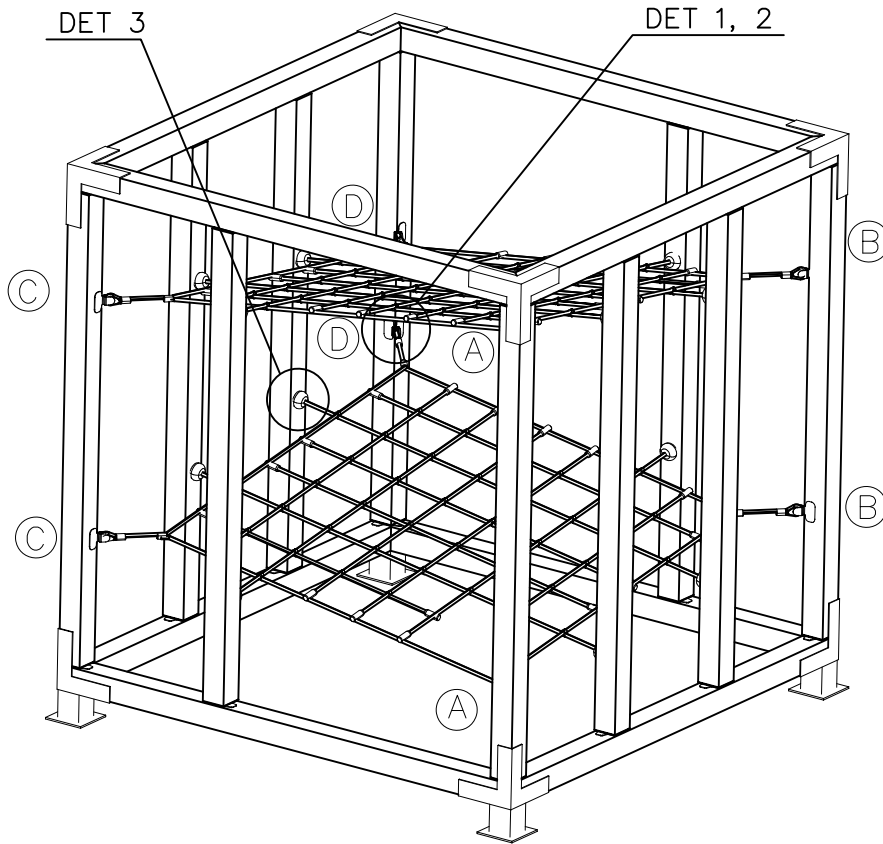

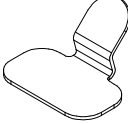
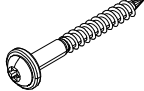
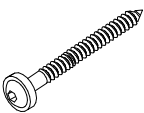
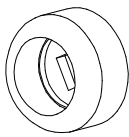
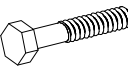
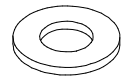
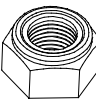
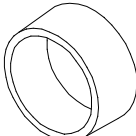
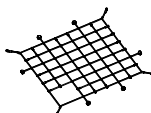
| | | | | | |
|---|---|-----|---|---------|-----|
| ① | 929561 | PCS | ② | 900240 | PCS |
| |  | 8 |  | Ø8x70 | 16 |
| ③ | 903093 | PCS | ④ | 905083 | PCS |
| |  | 12 |  | Ø32 | 8 |
| | Ø8x90 | | | | |
| ⑤ | 909568 | PCS | ⑥ | 980151 | PCS |
| |  | 4 |  | Ø16/8.4 | 8 |
| | M8x55 | | | | |
| ⑦ | 980150 | PCS | ⑧ | 905112 | PCS |
| |  | 4 |  | Ø22 | 8 |
| | M8 | | | | |
| | | PCS | | | PCS |
| ○ | 708339 | PCS | | | PCS |
| |  | | | | |
| | | PCS | | | PCS |
| | | PCS | | | PCS |

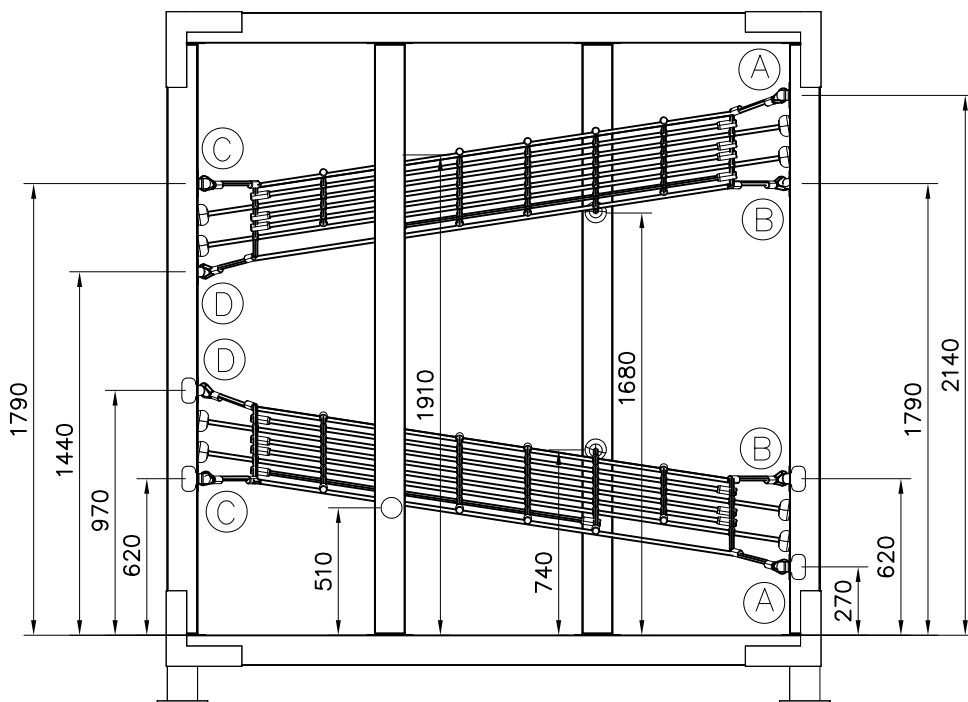

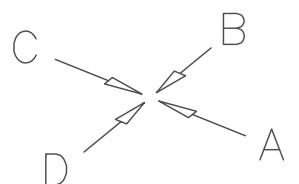
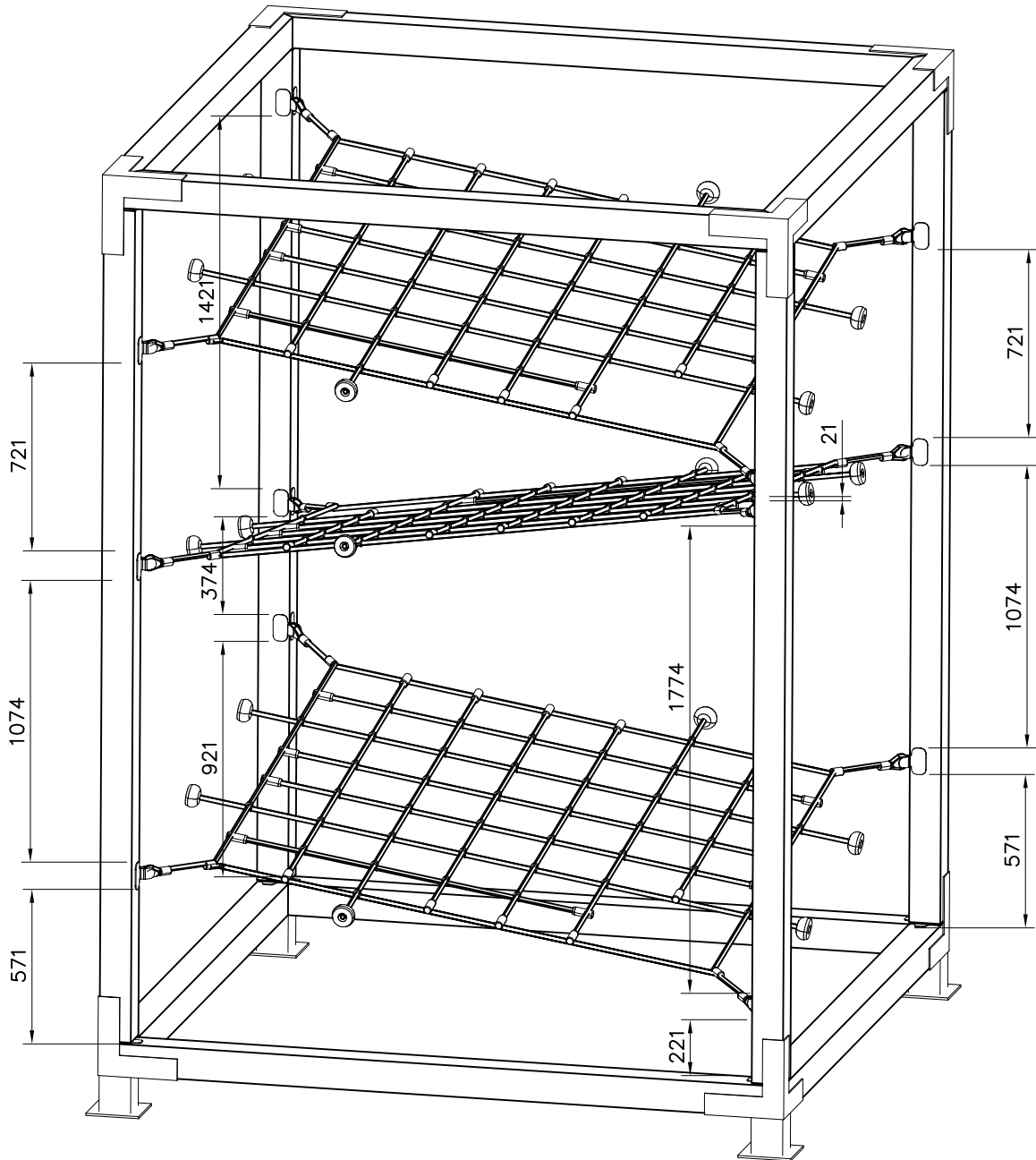

DET 1

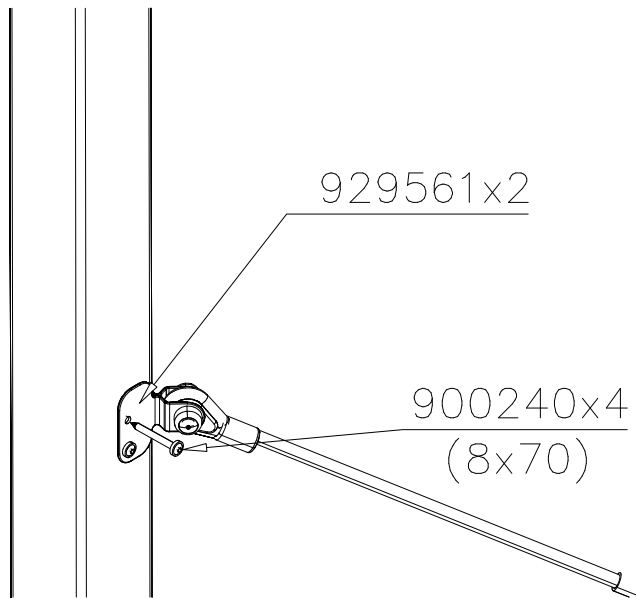

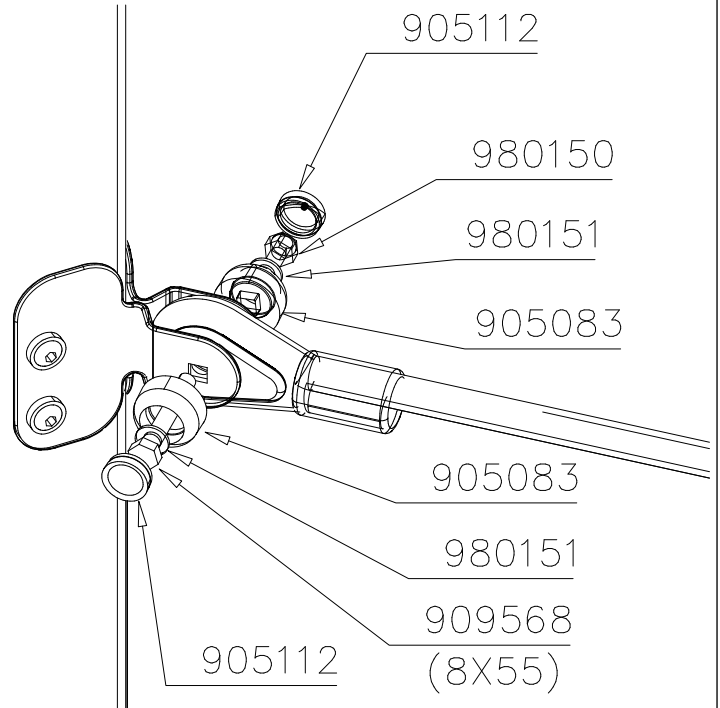

DET 2

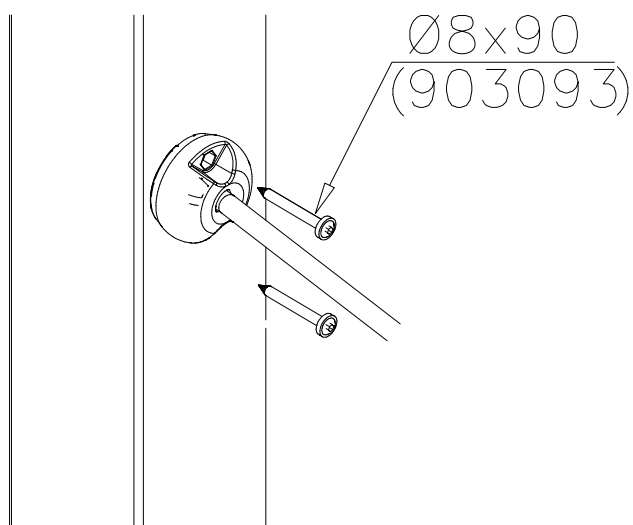

DET 3

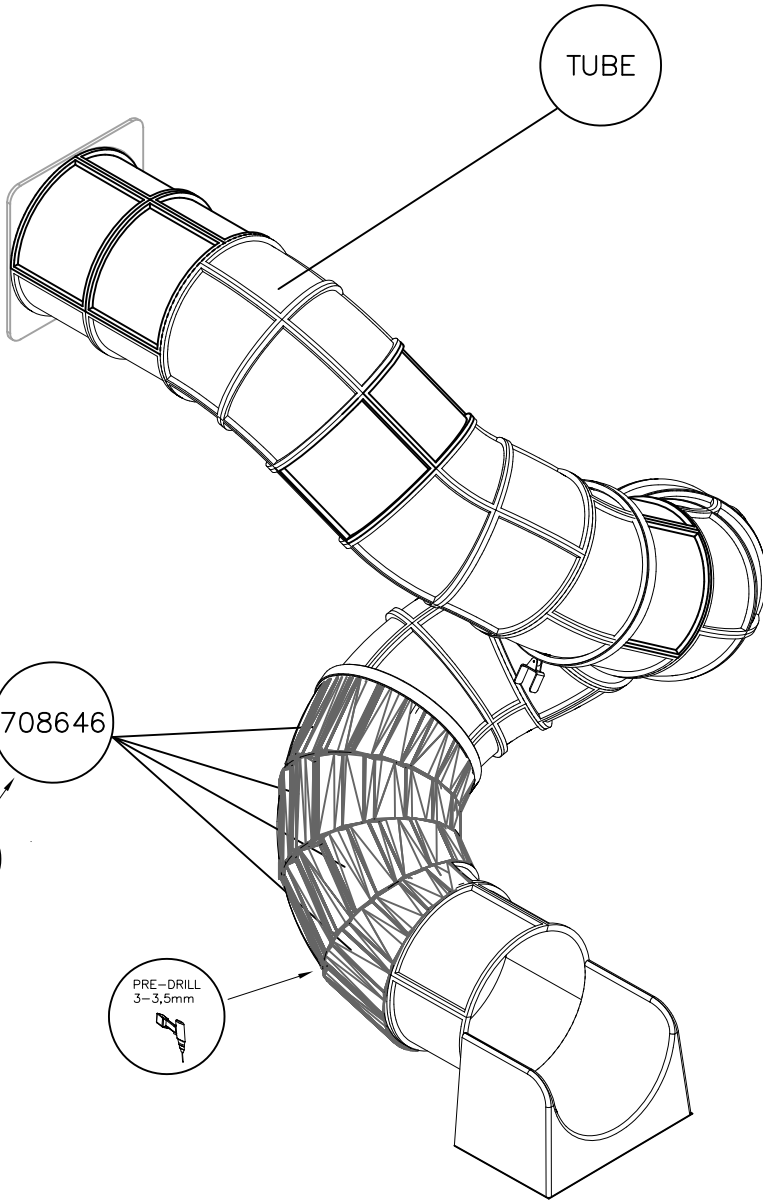

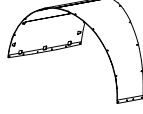

| | | | |
|---|-----|---|-----|
| ① 708646 | PCS | ② 909252 | PCS |
|  | 4 |  | 104 |
| 3x1347x515 | | Ø4.8x25 | |
| | PCS | | PCS |
| | | | |
| | PCS | | PCS |
| | | | |
| | PCS | | PCS |
| | | | |
| | PCS | | PCS |
| | | | |
| | PCS | | PCS |
| | | | |
| | PCS | | PCS |
| | | | |

Huom. Pystyttäessä tube- liukumäkeä korkean leikkivälineen yhteyteen, voidaan pystytystyössä tarvita nosturia, ellei paikalla ole tarpeeksi pystytyshenkilökuntaa.

1. Tarkista tuoteosaluettelon ja osiin merkittyjen tuotenumeroiden avulla, että kaikki osat sisältyvät toimitukseen.
2. Valitse välineelle paikka ottaen huomioon valmistajan asennusohjeessa ilmoittamat turvaetäisyydet, 2m turvaetäisyys jarrutuslaatikon edessä ja 1m sivuilla. Tube liukumäen alastuloalueen on vastattava 1m putoamiskorkeutta. Tee tarvittavat peruskaivannot jarrutuslaatikkoa varten.
3. Kokoa kehät sivujen 4 ja 5 mukaisesti huomioiden läpinäkyvät osat.
4. Liitä kehät toisiinsa asennusohjeen numeromerkintöjen mukaan. Sivulla 6 esitetään esimerkki kehien kokoamisesta. Huomioi ettei läpinäkyviä osia tule liukupintaan.
5. Asenna esikoottu lähtölevy putken yläpäähän ohjeen mukaiseen asentoon. Asenna jarrutuslaatikon 905850 perustusraudat asennusohjeen mukaisesti ja liitä putken alapäähän.
6. Nosta putkiliukumäki rakennelmaa vasten ja kiinnitä ohjeen mukaisilla kiinnikkeillä. Täytä jarrutuslaatikon alusta hiekalla.
7. Asenna mahdolliset liukumäen tukitolpat erillisen ohjeen mukaan.
8. Tee käyttöönottotarkastus ennen välineen käyttöönottoa toimitukseen sisältyvän pöytäkirjan mukaisesti. Pöytäkirja tulee dokumentoida. Muista, että pääsy välineeseen tulee estää, kunnes se on valmis, turvallinen ja kaikki asennustarvikkeet on viety pois.

Obs. När du lyfter upp en tuberutschbana mot en hög leku­trustning, kan det hända att du behöver använda en kran om det inte finns monteringspersoner på plats.

1. Kontrollera stycklistan och delarna i förpackningen med hjälp av produktnumren.
2. När du väljer platsen för utrustningen bör du beakta de säkerhetsavstånd som tillverkaren meddelat i monteringsanvisningarna. 2 m säkerhetsavstånd framför bromslådan och 1 m på sidorna. På Tubes- rutschbanan landningsområde måste det finnas motsvarande 1 m fallhöjd. Utför nödvändigt grundarbete för bromslådan.
3. Montera ringarna enligt sidorna 4 och 5 och beakta de genomskinliga delarna.
4. Montera ihop ringarna med varandra enligt numren i monteringsanvisningarna. På sidan 6 får du ett exempel på hur man monterar ringarna. Observera att det inte får komma några genomskinliga delar på glidytan.
5. Sätt fast den förmonterade startskivan på den övre delen enligt anvisningarna. Sätt fast bromslådan i enlighet med monteringsanvisningarna för fundamentjärnen 905850 och sätt fast i den nedre delen av röret.
6. Lyft upp tubrutschbanan mot konstruktionen och fäst med fästelement enligt anvisningarna. Fyll botten av bromslådan med sand.
7. Montera eventuella stöd­stolpar till rutschbanan enligt separata anvisningar.
8. Innan utrustningen tas i bruk ska en slutbesiktning i enlighet med protokollet i leveransen utföras. Protokollet måste dokumenteras. Kom ihåg att tillträde till utrustningen måste förhindras tills den är färdig monterad, säker och alla monterings­­tillbehör avlägsnats.

Please note! In the absence of sufficient installation staff you may need to use a crane to attach the Tube slide to a tall structure.

1. Use the parts list and the markings on the components to make sure that you have all of the necessary parts.
2. Choose a location for the product, taking into account the safety margins specified in the mounting instructions: leave 2 metres in front of the slide's end and 1 metre on both sides. The curve of the Tube slide must correspond to a total fall height of 1 metre. Prepare the ground for anchoring the end piece.
3. Assemble the tubular components in accordance with the instructions on pages 4 and 5, taking into account the positioning of transparent elements.
4. Join the components together following the numbering in the instructions. An example of how to assemble the tube is shown on page 6. Make sure that none of the transparent elements are used for the sliding surface.
5. Pre-assemble the top deck and position it at the upper end of the slide as shown in the instructions. Fix the steel anchors on the bottom of the slide (part No 905850) into place as instructed and attach to the bottom end of the tube.
6. Lift the tube up against the structure and fix into place using the mountings provided. Fill the area in front of and underneath the slide with sand.
7. Follow the instructions in the supplement to mount support posts if required.
8. Inspect the installation thoroughly using the checklist provided. Document the completed checklist carefully. Remember to stop children from using the product until it has been fully built and safety-tested and all mounting equipment has been cleared away.

Zur Beachtung: Beim Aufstellen der Röhren-Rutschbahn in Verbindung mit einem hohen Spielgerät, ist evtl. für die Aufstellarbeiten ein Kran erforderlich, falls nicht ausreichend Installationspersonal vor Ort verfügbar ist.

1. Überprüfen Sie die Lieferung auf Vollständigkeit, indem Sie das Teileverzeichnis mit der Lieferung abgleichen.
2. Wählen Sie einen Standort für das Gerät entsprechend der vom Hersteller in der Installationsanleitung genannten Sicherheitsabstände, 2 m Sicherheitsabstand vor dem Auslaufstück und 1m zur Seite. Der Auslaufbereich der Röhren-Rutschbahn muss 1m Fallhöhe entsprechen. Führen Sie die nötigen Aushubarbeiten für das Auslaufstück durch.
3. Bauen Sie entsprechend der Seiten 4 und 5 die Ringe unter Berücksichtigung der durchsichtigen Teile zusammen.
4. Verbinden Sie die Ringe entsprechend den in der Montageanleitung genannten Nummernmarkierungen. Auf Seite 6 finden Sie ein Beispiel für das Zusammenfügen der Ringe. Achten Sie darauf, dass keine durchsichtigen Teile auf die Rutschflächen kommen.
5. Befestigen Sie die vormontierte Ablaufplatte in der korrekten Position entsprechend der Anleitung am oberen Ende des Rohres. Montieren Sie die Fundamenteisen nach Anleitung am Auslaufstück 905850 und befestigen Sie es am unteren Ende.
6. Heben Sie die Röhrenrutschbahn an die Konstruktion und befestigen Sie sie mit den Befestigungsteilen entsprechend der Anleitung. Füllen Sie den Untergrund am Auslaufstück mit Sand auf.
7. Montieren Sie eventuelle Stützpfeiler der Rutschbahn nach einer gesonderten Anleitung.
8. Führen Sie eine Inbetriebnahmeüberprüfung entsprechend des im Lieferumfang enthaltenen Protokolls durch, bevor das Gerät benutzt wird. Das Protokoll muss aktenkundig dokumentiert werden. Denken Sie daran, dass der Zugang zum Gerät verhindert werden muss, bis es fertig und sicher ist und alle Installationsgeräte entfernt sind.

N.B. Lorsque le toboggan - tube est monté sur un équipement haut, une grue peut être nécessaire pour les travaux de montage s'il n'y a pas suffisamment de personnel de montage sur place.

1. Vérifier à l'aide de la liste des pièces et des numéros de produit marqués sur les pièces que la livraison comprend toutes les pièces nécessaires.
2. Choisir un bon emplacement pour l'équipement, compte tenu des distances de sécurité indiquées par le fabricant dans les instructions de montage, une distance de sécurité de 2m devant la boîte de freinage et de 1m sur les côtés. La zone de descente du toboggan tube doit correspondre à une hauteur de descente d'un mètre. Effectuer les excavations de base pour la boîte de freinage.
3. Assembler les cadres conformément aux pages 4 et 5 en prenant en considération les pièces transparentes.
4. Relier les cadres les uns aux autres conformément aux numérotations des instructions de montage. Un exemple du montage des cadres est donné à la page 6. Veiller à ce que des pièces transparentes ne soient pas placées sur le côté glissement.
5. Monter la plaque de départ prémontée à l'extrémité supérieure du tube dans la position indiquée dans les instructions. Monter les fers de fondation 905850 de la boîte de freinage conformément aux instructions de montage et les relier à l'extrémité inférieure du tube.
6. Soulever le toboggan- tube contre la structure et le fixer à l'aide des pièces de fixation conformément aux instructions. Remplir le fond de la boîte de freinage avec du sable.
7. Monter les poteaux de support éventuels du toboggan conformément aux instructions séparées.
8. Effectuer un contrôle de mise en service conforme au procès-verbal compris dans la livraison avant la mise en service de l'équipement. Ce procès-verbal doit être documenté. Ne pas oublier d'empêcher l'accès à l'équipement jusqu'à ce que celui-ci soit prêt et sûr et que tous les outils de montage aient été enlevés.

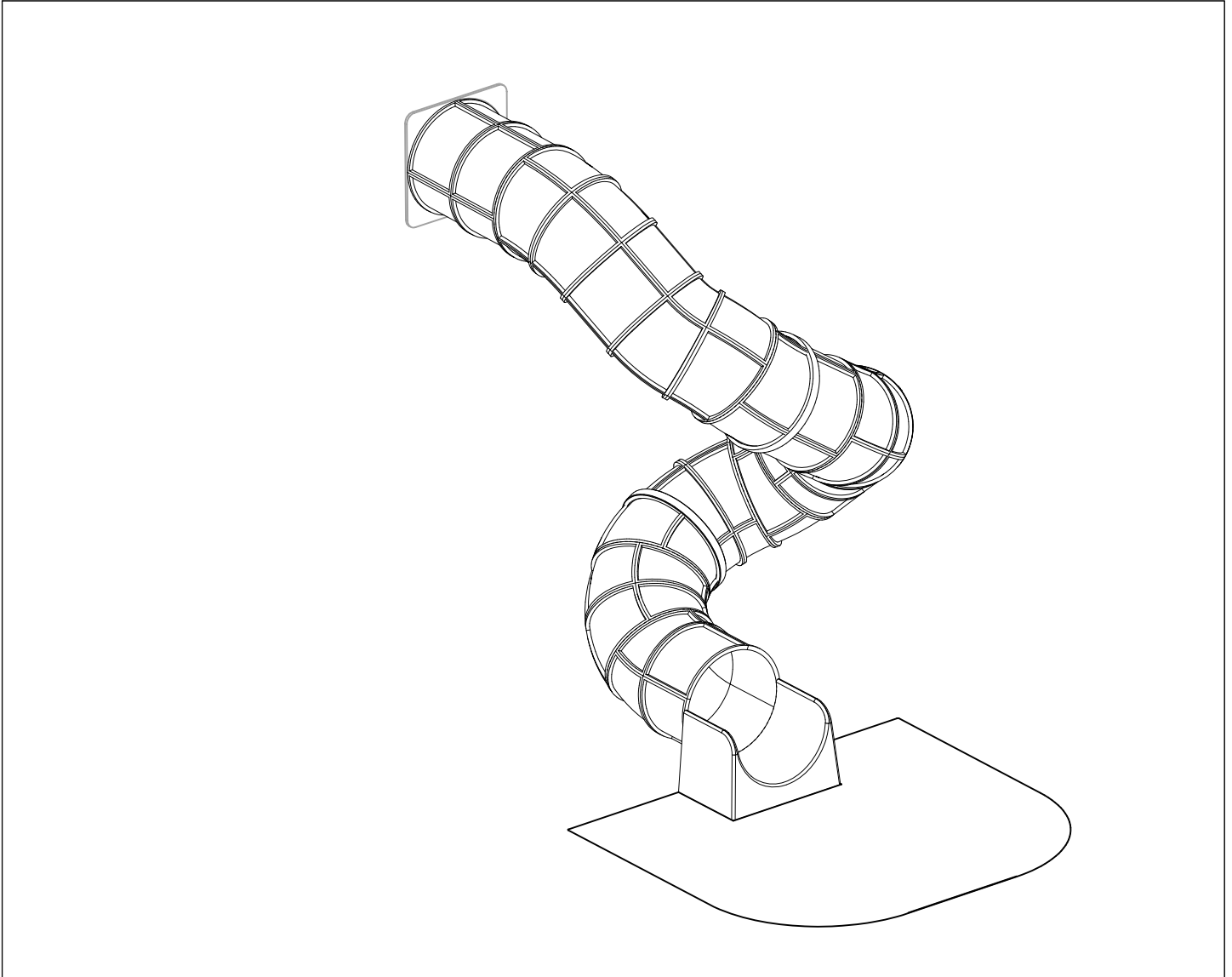



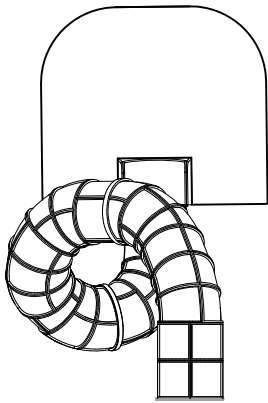



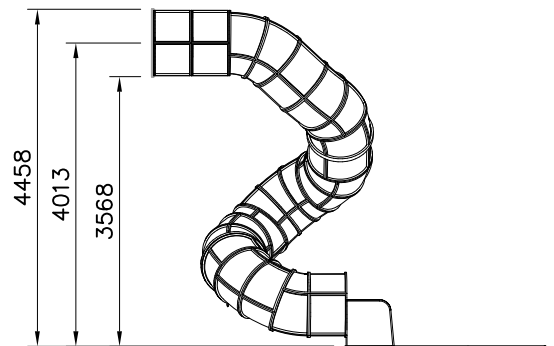

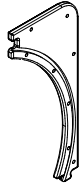
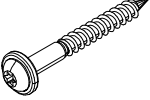

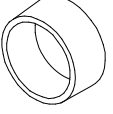
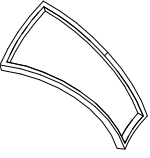
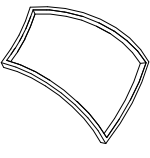
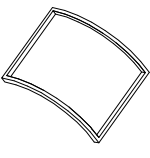
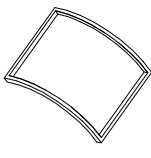

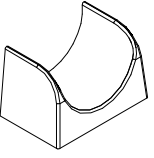
1 : 100

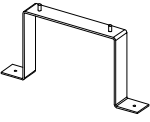

1 : 100



| | | | | | | | | | | | |
|---|-----|---|-----|---|-----|---|-----|---|------|---|------|
| | PCS | 708280-705 | PCS | 900240 | PCS | 903533 | PCS | 905086 | PCS | 911159 | PCS |
| | |  | 4 |  | 14 |  | 6 |  | 4 |  | 1096 |
| | | | | Ø8x70 | | SRL12 | | Ø44/13.5 | | GREY Ø22 | |
| 905801 | PCS | 905811 | PCS | 905821 | PCS | 905829 | PCS | 911158 | PCS | 905850 | PCS |
|  | 34 |  | 34 |  | 6 |  | 6 |  | 1016 |  | 1 |
| GREY | | GREY | | GREY | | CLEAR | | GREY | | | |
| 905859 | PCS | 905860 | PCS | 909205 | PCS | 909248 | PCS | 909274 | PCS | 980150 | PCS |
|  | 2 |  | 2 |  | 516 |  | 4 |  | 4 |  | 520 |
| 6x80x850 | | | | 8x60 | | M12 | | 8x30 | | M8 | |
| 980151 | PCS | | PCS | | PCS | | PCS | | PCS | | PCS |
|  | 8 | | | | | | | | | | |
| Ø16/8.4 | | | | | | | | | | | |
| | PCS | | PCS | | PCS | | PCS | | PCS | | PCS |
| | | | | | | | | | | | |
| | PCS | | PCS | | PCS | | PCS | | PCS | | PCS |
| | | | | | | | | | | | |

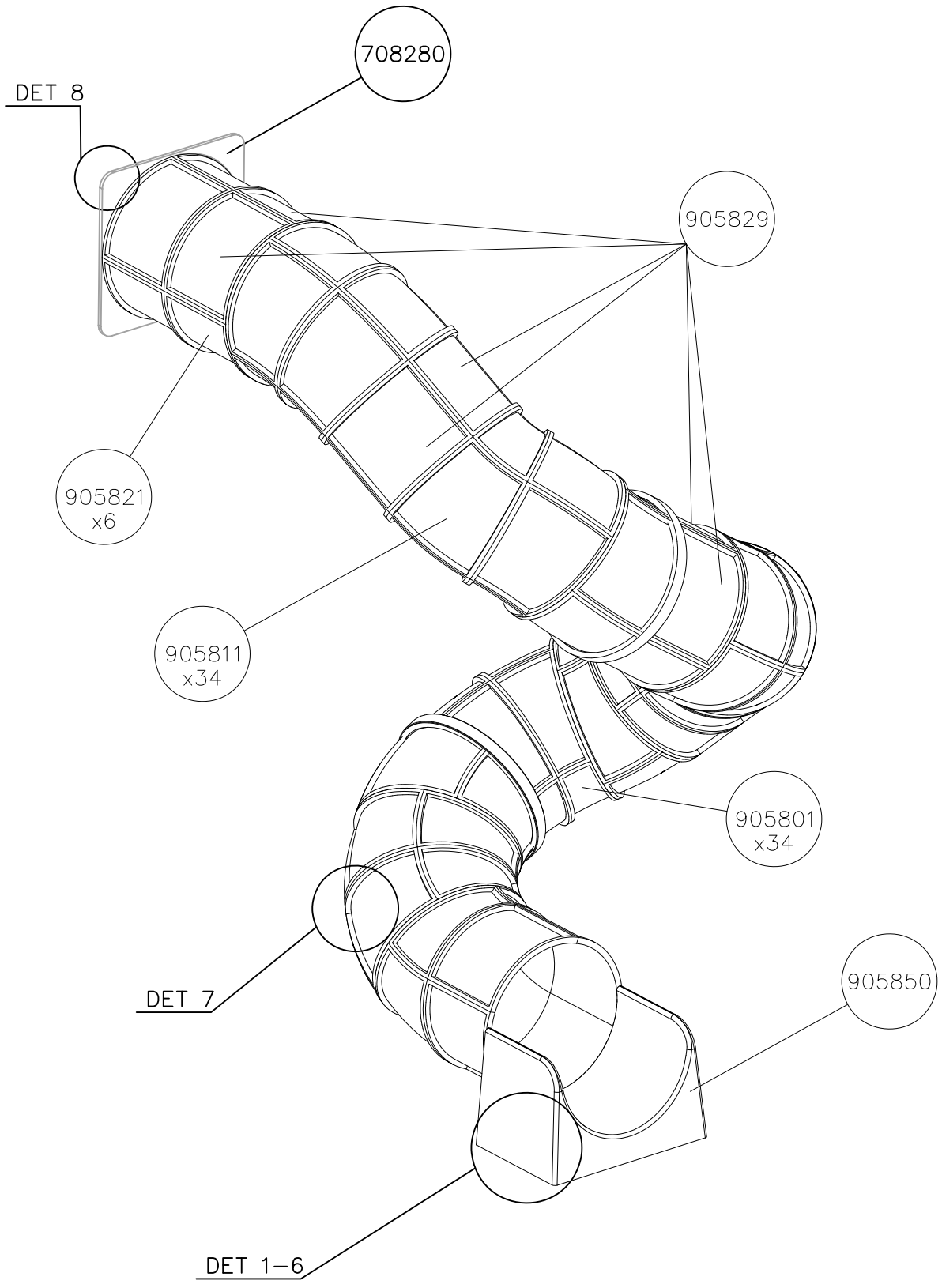

DET 1

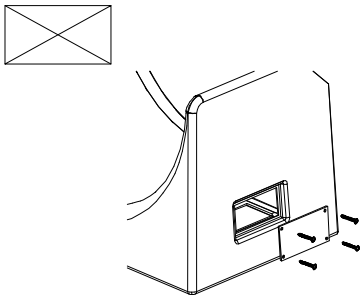

Access- and maintenance panel.
Asennus- ja huolto luukku.

DET 2

DET 3

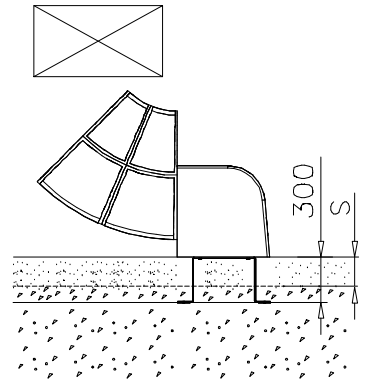

DET 4

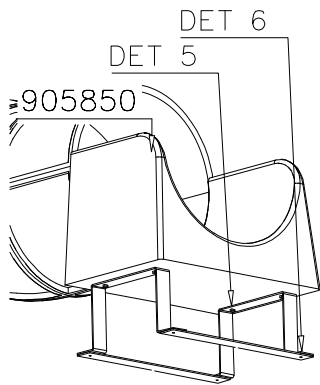

DET 5

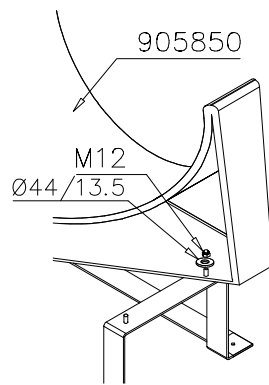

DET 6

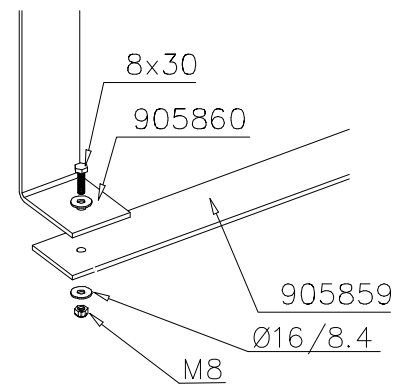

DET 7

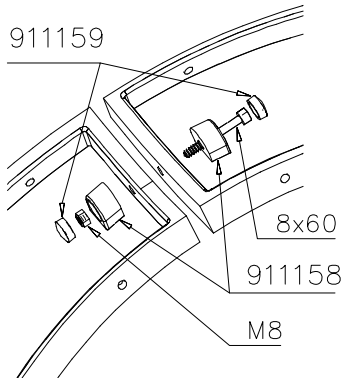

DET 8

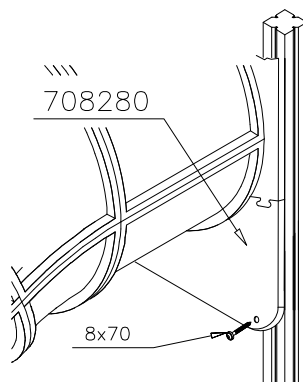

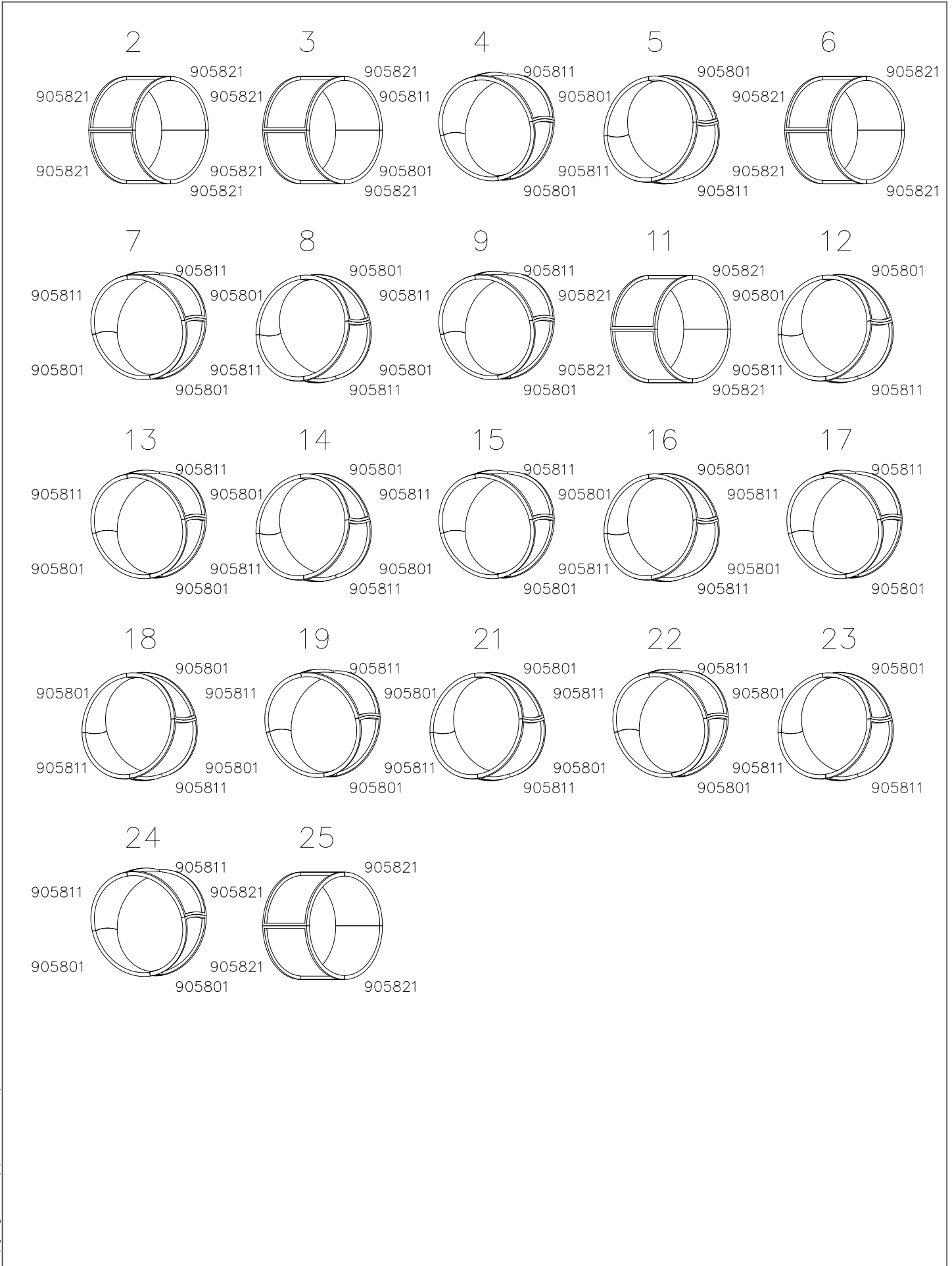







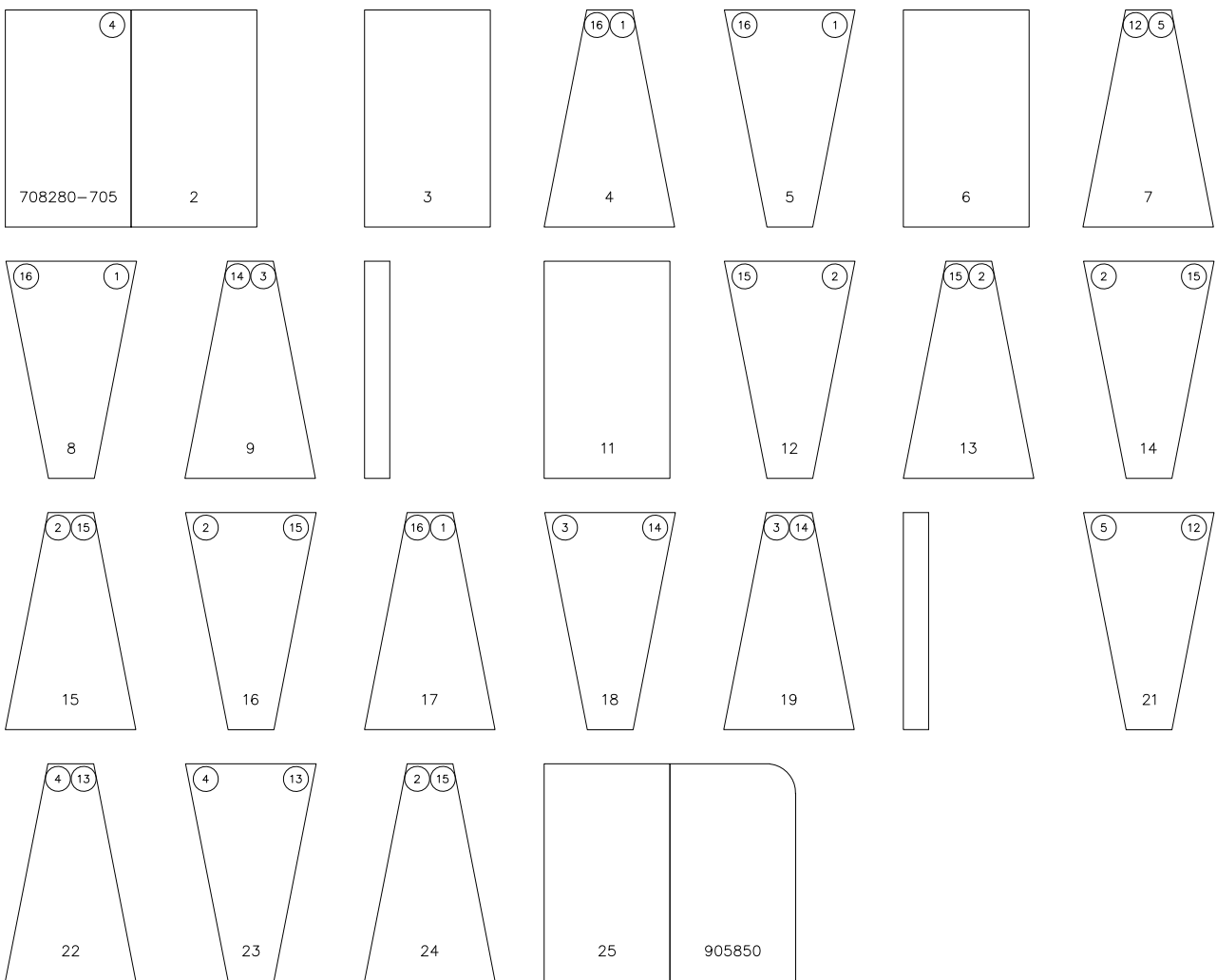
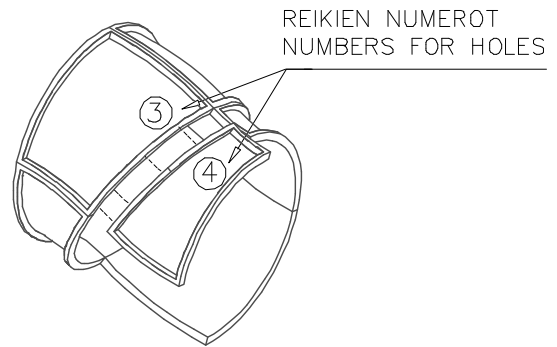



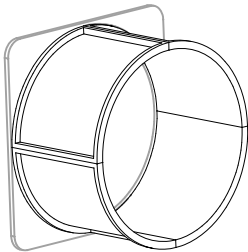
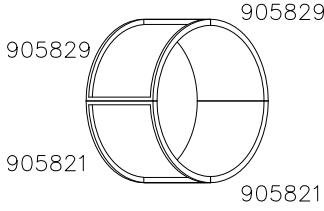

















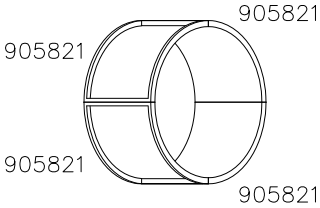



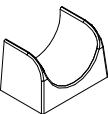



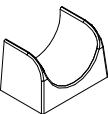

Esimerkki putken kokoamisesta
Example of installation

LIUKUPINTAAN EI SAA TULLA
LÄPINÄKYVIÄ MODUULEJA!!

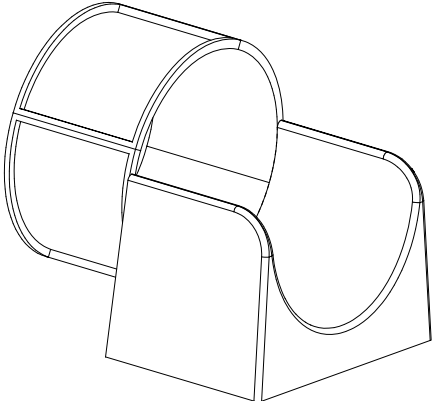
NO TRANSPARENT PIECES ON
SLIDING SURFACE!!

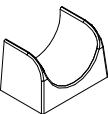

Valmiiksi kasattujen osien osakokoonpanot ja vara-osa listat.
Ready installed component subassemblies and spare part list.

| | | | | | | | | |
|--|--|--|--|--|--|--|--|--|
|  | <div style="text-align: center;">2</div>  <table border="1" data-bbox="895 931 1468 1310"> <tr> <td>708280-705 </td> <td>909205 x 12 </td> <td>980150 x 12 </td> </tr> <tr> <td>911158 x 40 </td> <td>909208 x 16 </td> <td>909119 x 16 </td> </tr> </table> | | 708280-705  | 909205 x 12  | 980150 x 12  | 911158 x 40  | 909208 x 16  | 909119 x 16  |
| 708280-705  | 909205 x 12  | 980150 x 12  | | | | | | |
| 911158 x 40  | 909208 x 16  | 909119 x 16  | | | | | | |
| <div style="text-align: center;">25</div>  <table border="1" data-bbox="172 1724 745 2101"> <tr> <td>909205 x 20 909206 x 8 </td> <td>980150 x 20 </td> <td>911158 x 40 </td> </tr> <tr> <td>905850 </td> <td>909208 x 8 </td> <td>980151 x 8 </td> </tr> </table> <p>Position of the box: 70 degrees</p> | 909205 x 20 909206 x 8  | 980150 x 20  | 911158 x 40  | 905850  | 909208 x 8  | 980151 x 8  | <p>909252 x 13 </p> <p>700413 x 1 </p> |  |
| 909205 x 20 909206 x 8  | 980150 x 20  | 911158 x 40  | | | | | | |
| 905850  | 909208 x 8  | 980151 x 8  | | | | | | |

**Tuotekyltti tulee tuotteen mukana yhdellä seuraavista tavoista:****1) Metallinen tuotekyltti ja kiinnitysruuvit**

- Kiinnitä tuotekyltti ruuveilla tolppaan noin 2 metrin korkeuteen kuvan 1 mukaisesti.

2) Tuotekylttitarra

- Puhdista maalattu metalli- tai vaneripinta pölystä ja kosteudesta. Liimaa tarra kuvan 2 mukaisesti.
- Huom. Älä kiinnitä tarraa karheapintaiseen laminaattiin tai maalattuun puuhun.

Vår produktmärkning levereras på ett av följande sätt:**1) Produktskylt i metall**

- Fäst skylten med de medföljande skruvarna

2) Självhäftande produktetikett

- Rengör den pulverlackerade metallytan eller laminatyten så att den blir fri från smuts och fukt. Fäst etiketten enligt fig. 2.
- Obs! Fäst ej etiketten på detaljer med skrovlig yta eller på målat trä.

Product label is delivered by one of following ways:**1) Metal product label and screws**

- Fasten the label with screws.

2) Label sticker

- Clean the painted metal or plywood surface from dirt and moisture. Fasten the sticker as shown in the figure 2.
- Note. Do not attach the sticker to rough surfaced laminate or painted wood.

La plaque d'informations produit est livrée sous l'une de ces 3 formes :**1) Plaque métallique et vis**

- Fixez la plaque à l'aide des vis.

2) Etiquette autocollante

- Avant de coller l'étiquette, nettoyez le composant métallique peint ou la plaque de contreplaqué, de toute saleté. La surface doit être sèche (voir image 2).
- Attention, ne pas coller l'étiquette sur une surface lamellé-collée irrégulière ou sur du bois peint.



Die Auslieferung des Produktaufklebers erfolgt auf eine dieser Arten:**1) Produkt-Schild aus Metall incl. Schrauben**

- Die Befestigung des Schildes erfolgt mittels der Schrauben.

2) Aufkleber

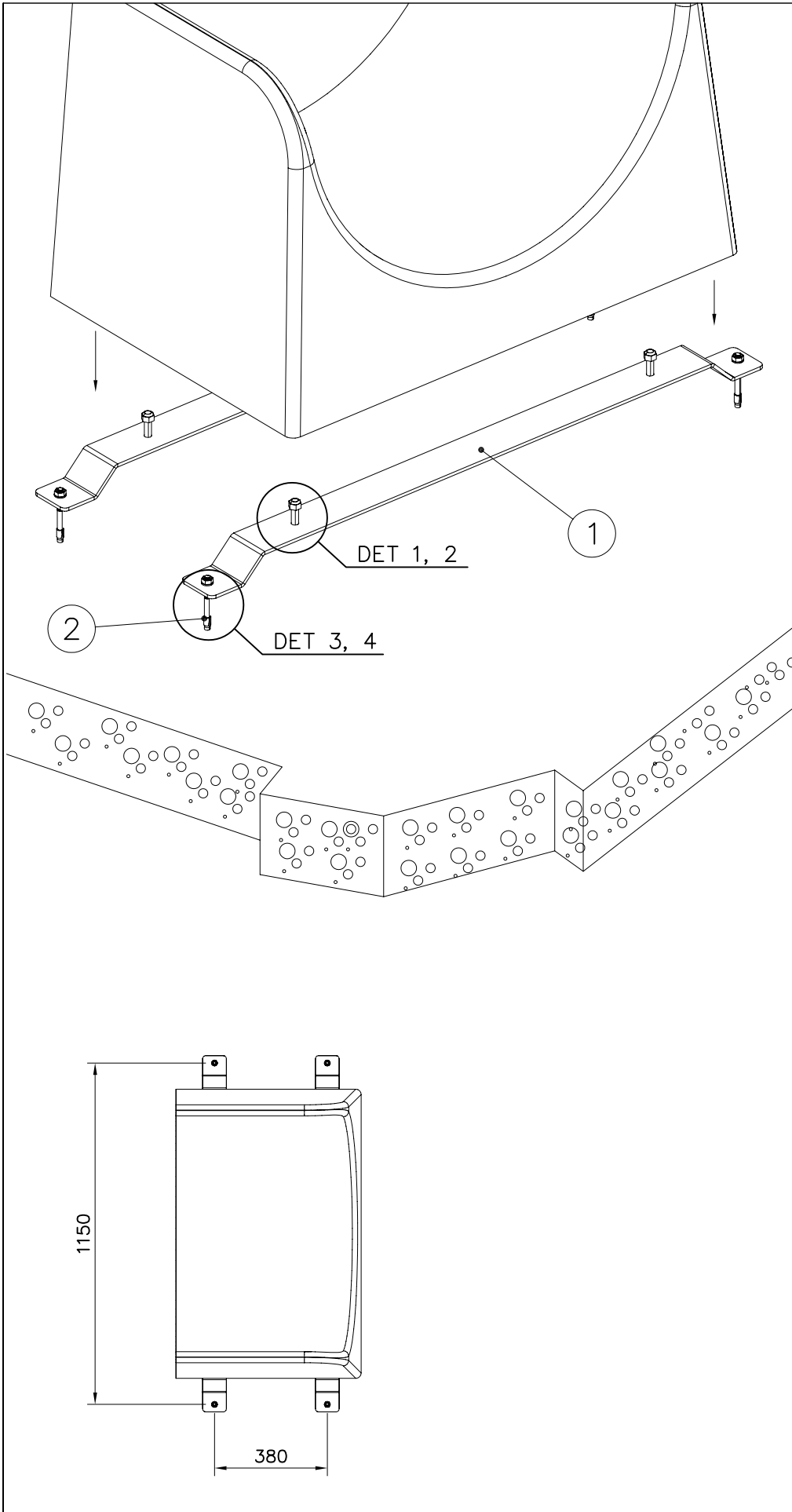
- Entfernen Sie zunächst Schmutz und Feuchtigkeit vom lackierten Metall bzw. von der Holzoberfläche und bringen Sie den Aufkleber wie im Bild oben rechts beschrieben auf den gesäuberten Untergrund auf.
- Beachten Sie: Bringen Sie den Aufkleber nicht auf raues laminiertes oder lackiertes Holz an.

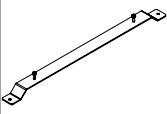

| | | | |
|---|-----|---|-----|
| ① 905858 | PCS | ② 909628 | PCS |
|  | 2 |  | 4 |
| 1200x80x90 | |  | |
| | PCS | M10x100 | PCS |
| | | | |
| | PCS | | PCS |
| | | | |
| | PCS | | PCS |
| | | | |
| | PCS | | PCS |
| | | | |
| | PCS | | PCS |
| | | | |
| | PCS | | PCS |
| | | | |

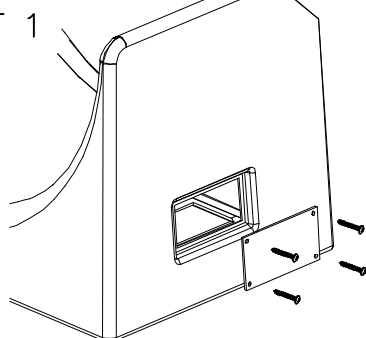
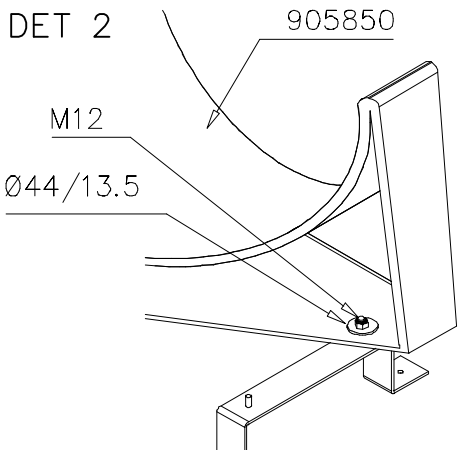
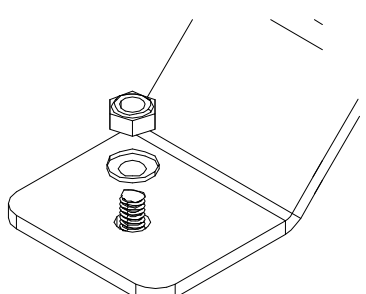
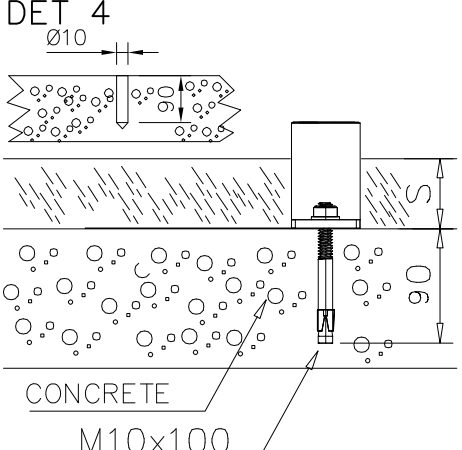
| | | |
|--|--|--|
| <p>DET 1</p>  <p>Access- and maintenance panel. Asennus- ja huolto luukku.</p> | <p>DET 2</p>  <p>905850</p> <p>M12</p> <p>Ø44/13.5</p> | <p>DET 3</p>  |
| <p>DET 4</p>  <p>Ø10</p> <p>90</p> <p>CONCRETE</p> <p>M10x100</p> | | |
| | | |
| | | |

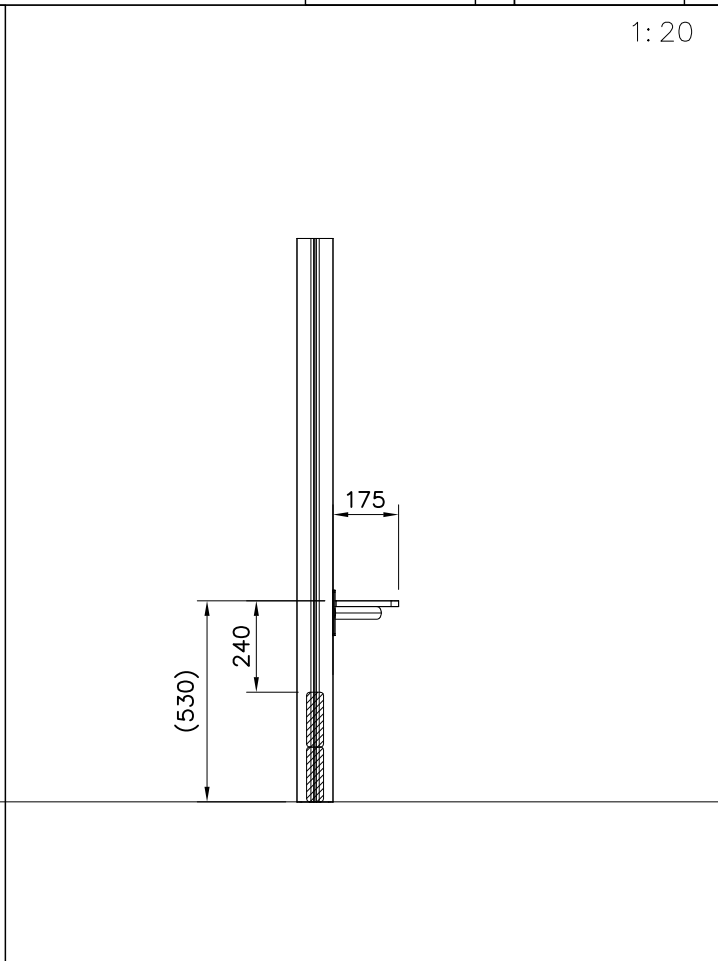
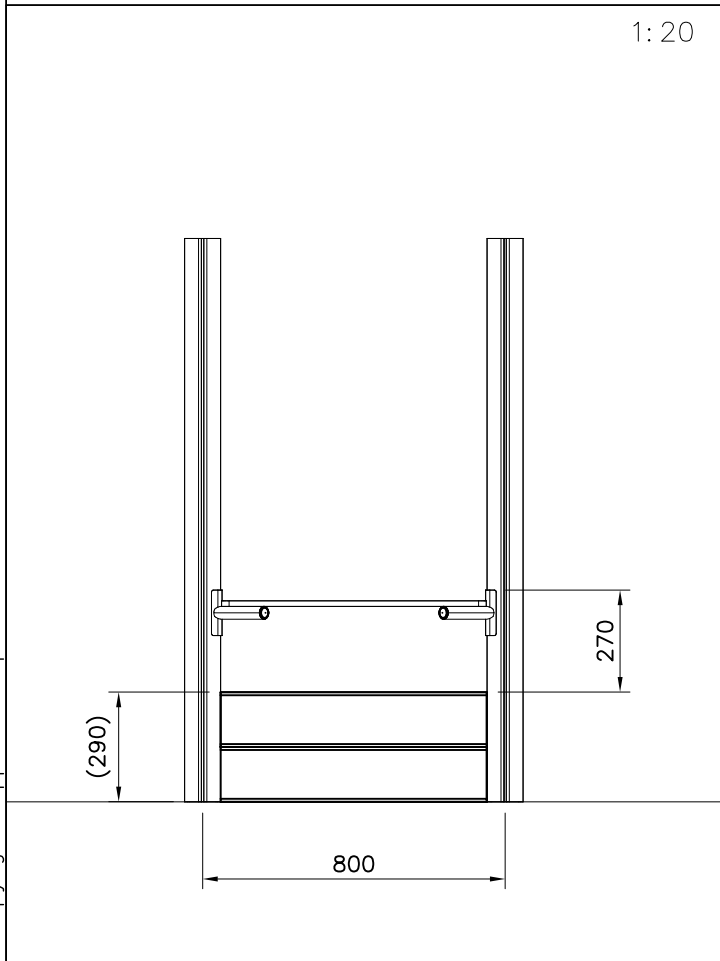
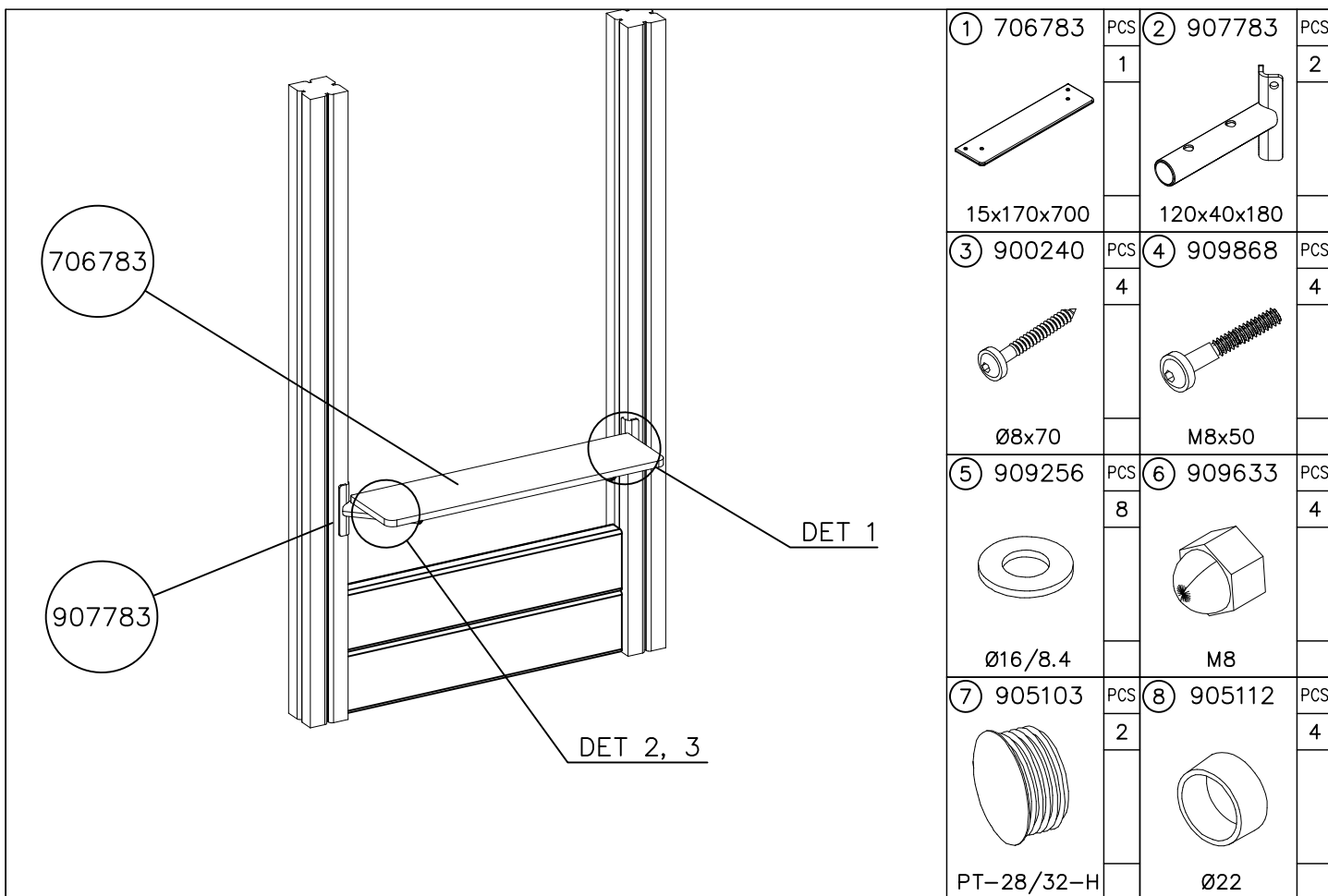

DET 1

Pre-drill hole
 Esireikä

Ø5 ↓ 50

907783

Ø16/8.4

(909256)

Ø8x70

(900240)

DET 2

907783

905103

DET 3

905112

M8x50

(909868)

706783

Ø16/8.4

(909256)

M8

(909633)