



LAPPSET®
BETON FOUNDATION

FOOT

DATE: 27.10.2015

1(1)

② 905104	PCS		PCS
	4		
 M10	PCS		PCS



905104

LAPPSET® DEEP FOUNDATION

FOOT

DATE: 15.5.2018

1(1)



①	909511	PCS	②	909519	PCS
		1			1
	90x90x650			50x380x380	

③	909637	PCS	④	909638	PCS
		4			8
	M10			Ø20/10.5	

⑤	909639	PCS	⑥	905104	PCS
		4			4
	M10x25			M10	

OPTION FOOT

①	911155	PCS			PCS
		1			
	90x90x650				

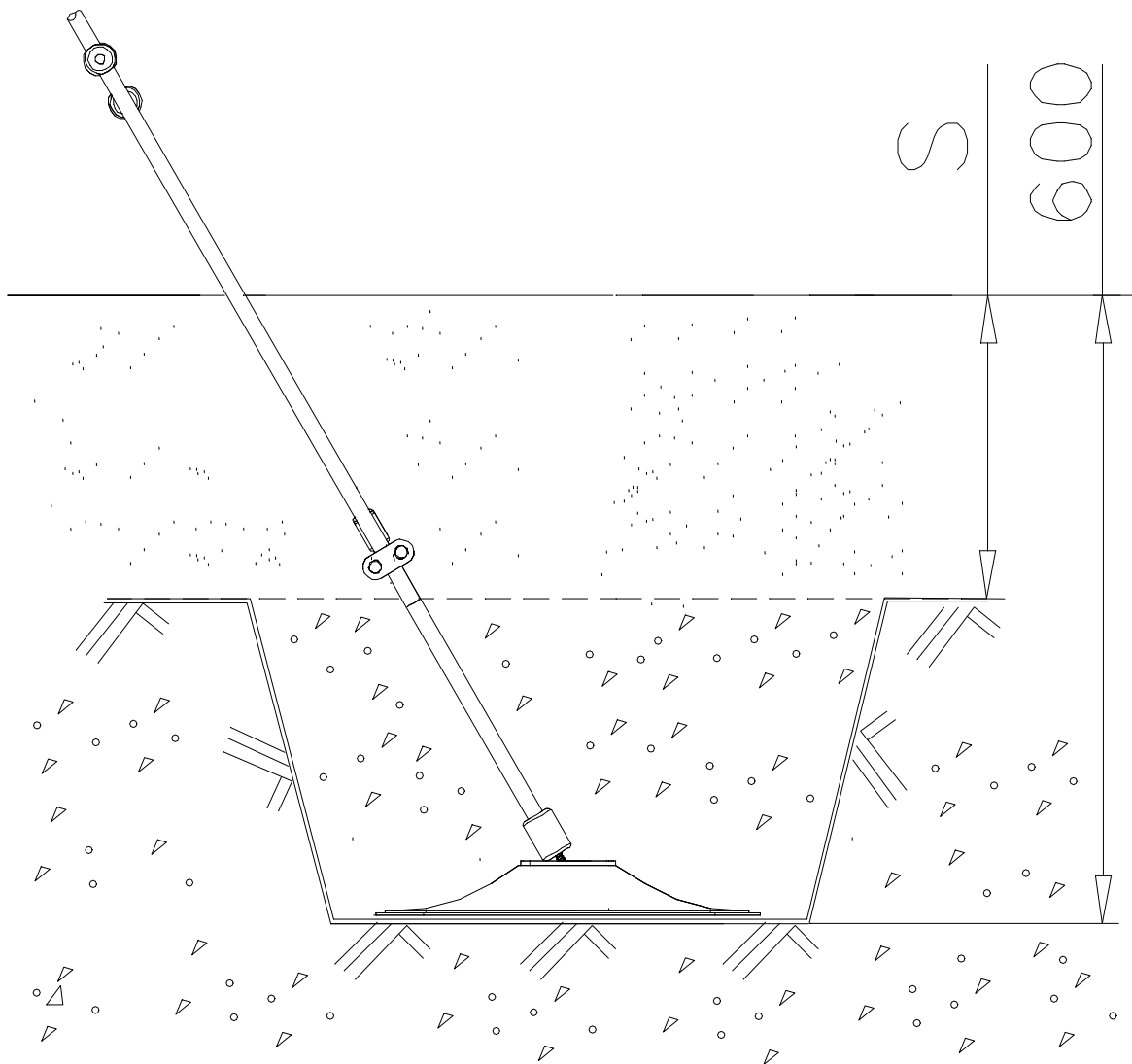
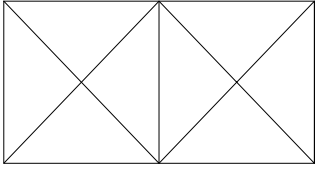

LAPPSET® DEEP FOUNDATION

ROPE LADDER

DATE: 30.6.2016

1(1)

① 905051	PCS	② 909519	PCS
	2		2
Ø24/8.4		50x380x380	
③ 909867	PCS	④ 909633	PCS
	2		2
M8x70		M8	
⑤ 903093	PCS		PCS
	4		
Ø8x90			
○ 706462	PCS	○ 707393	PCS
	1		1
+1470		+1970	

M12
(909248)

ROPE LADDER COLOR OPTIONS

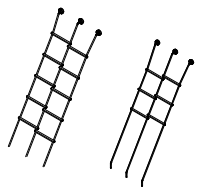

xxxxxx-301	BLUE
xxxxxx-302	RED
xxxxxx-303	BEIGE
xxxxxx-304	GRAY
xxxxxx-305	BLACK
xxxxxx-306	YELLOW

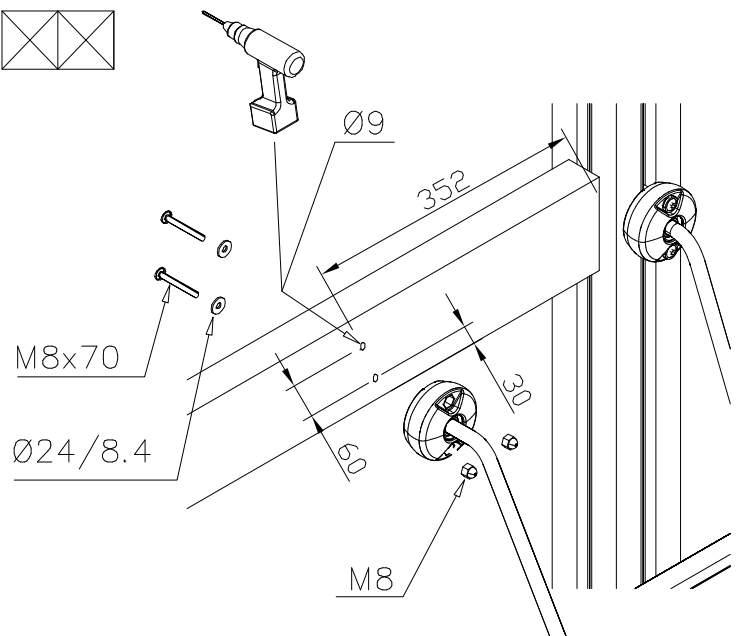
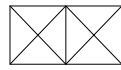
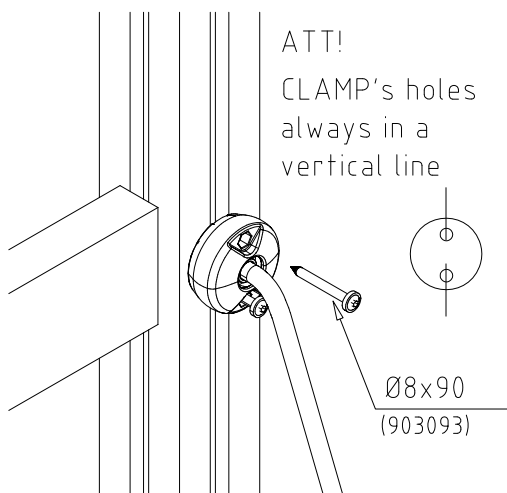
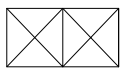





① 706510	PCS	② 907724	PCS
	1		2
45x120x1030			
③ 905083	PCS	④ 909866	PCS
	4		4
Ø32		M8x60	
⑤ 980151	PCS	⑥ 980150	PCS
	4		4
Ø16/8.4		M8	
⑦ 905112	PCS	⑧ 900240	PCS
	4		4
Ø22		Ø8x70	

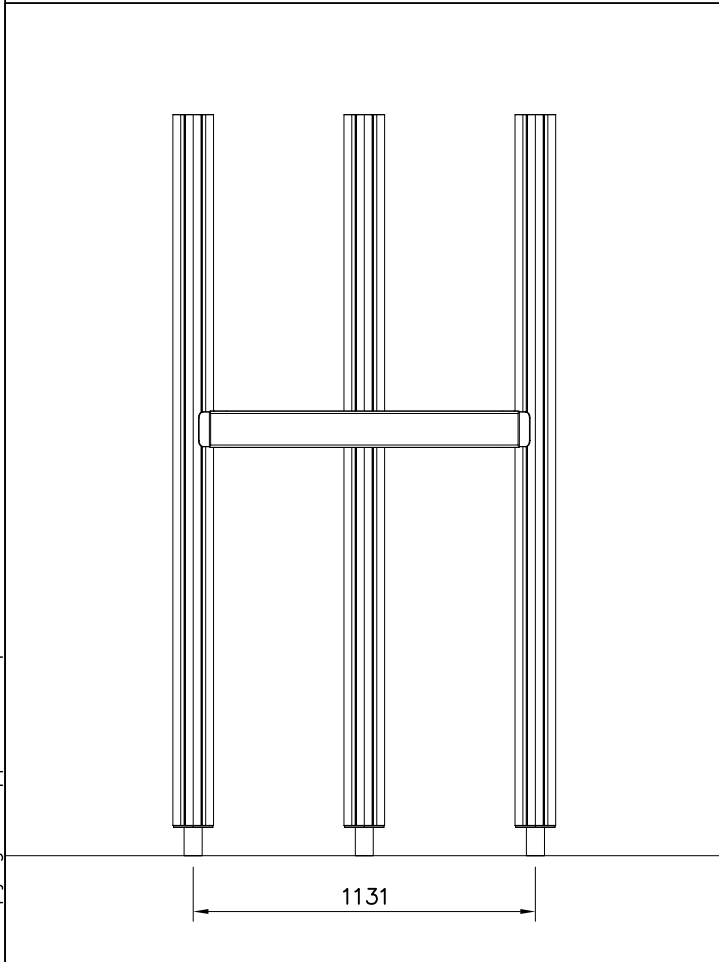

BOOM OPTIONS		
706510	706510-602	DARK BROWN
	706510-603	LIGHT BROWN
	706510-604	LIGHT GRAY
45x120x1030		

DET 1



DET 2 M8x60
(909866)

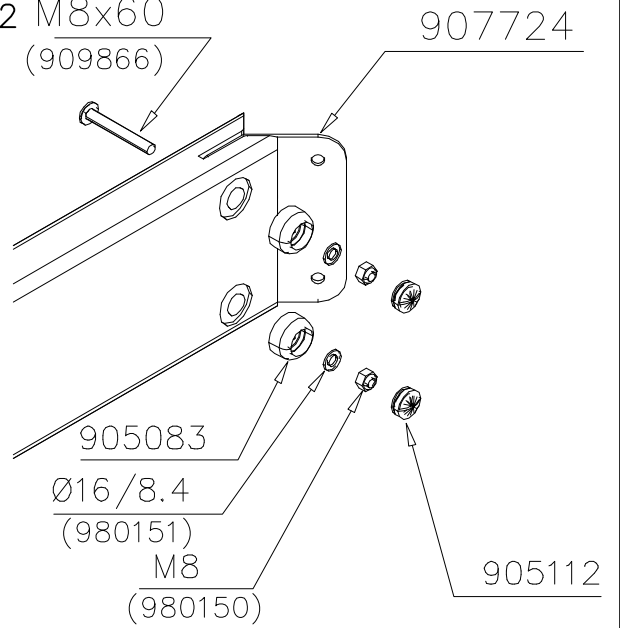

DET 3



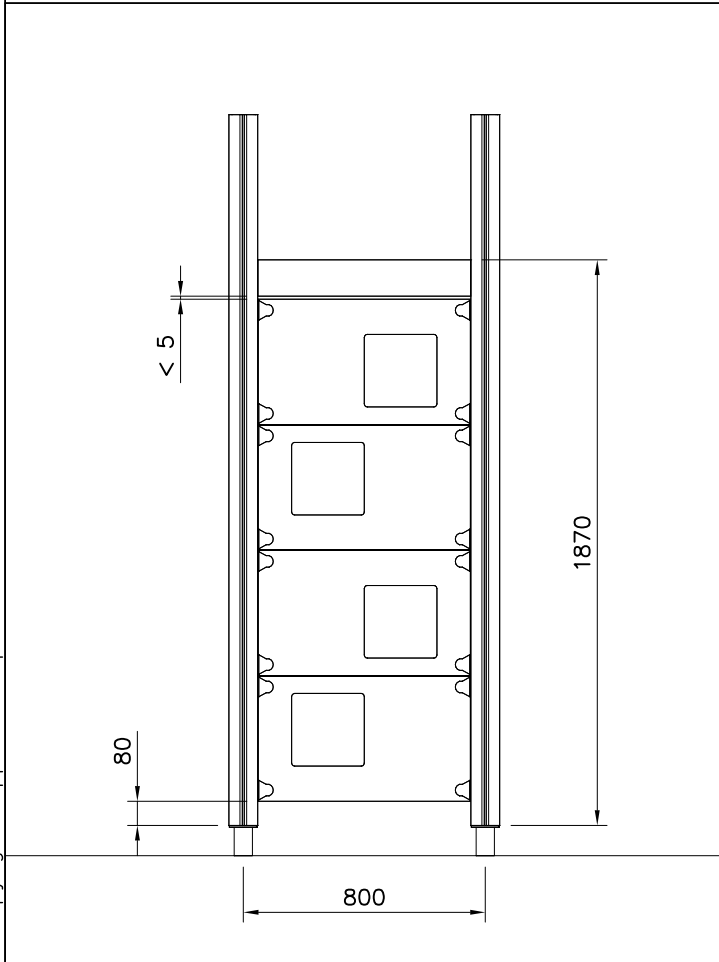
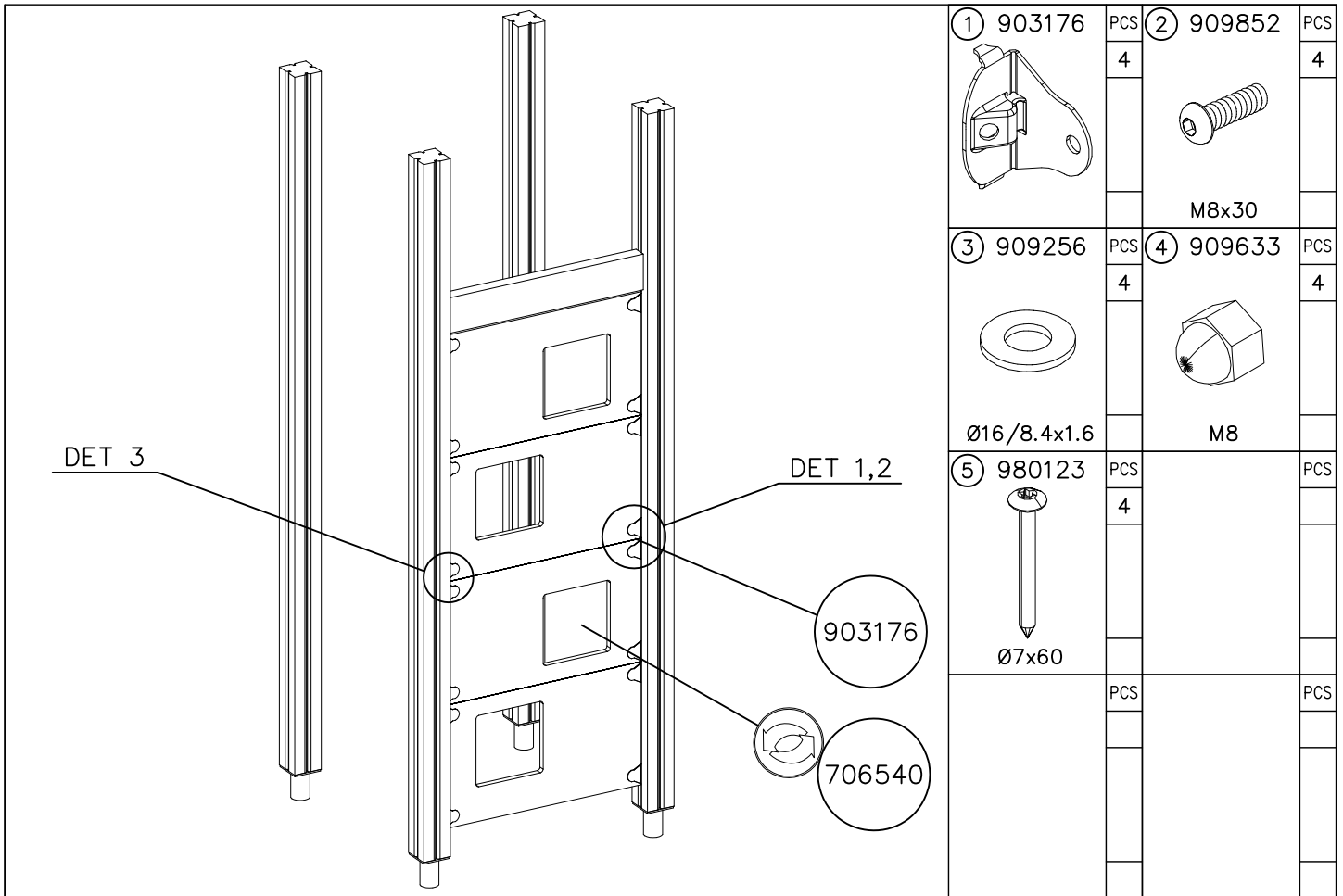

WALL OPTIONS		
706540	706540-701	BLUE
	706540-702	YELLOW
	706540-703	LIME
	706540-704	DARK GRAY
	706540-705	LIGHT GRAY
	706540-706	RED
	706540-707	GREEN
	706540-708	FUXIA
20x702x415		

DET 1

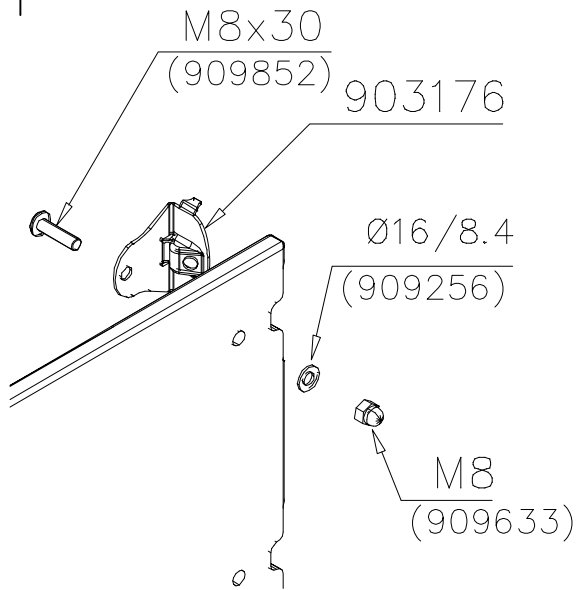

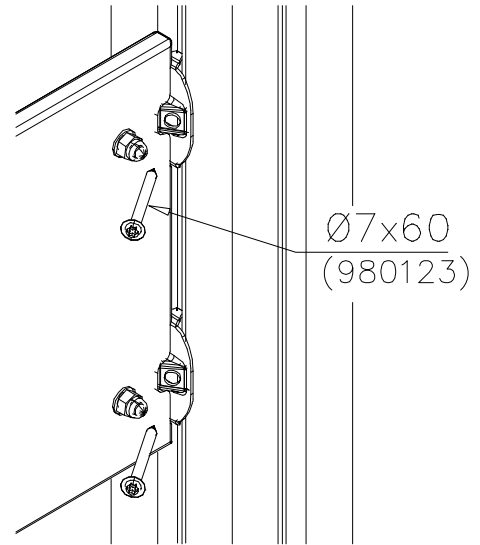

DET 2



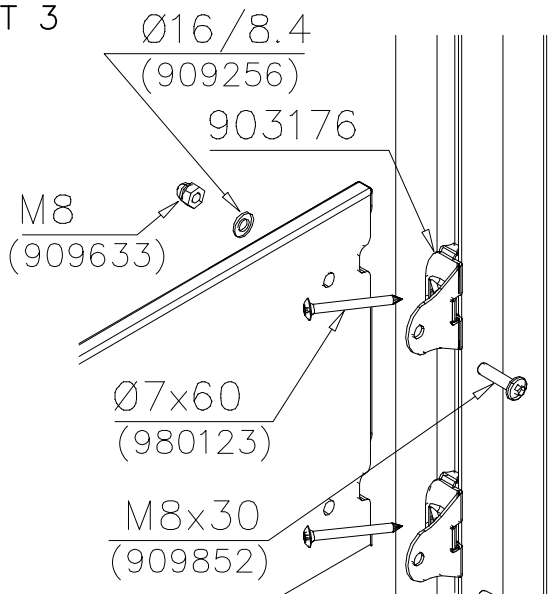

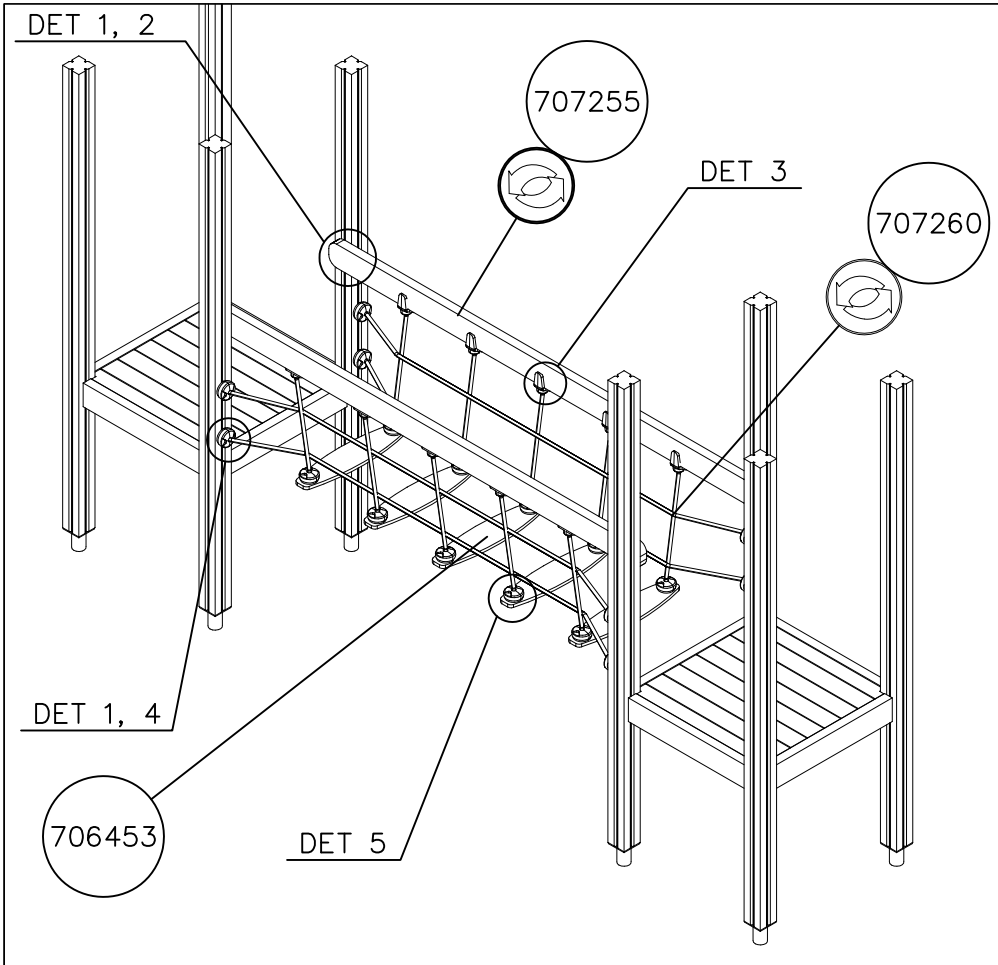

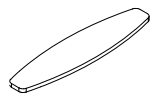
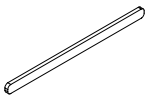
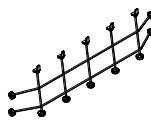
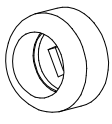
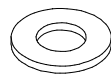
DET 3

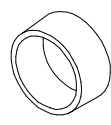
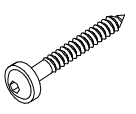

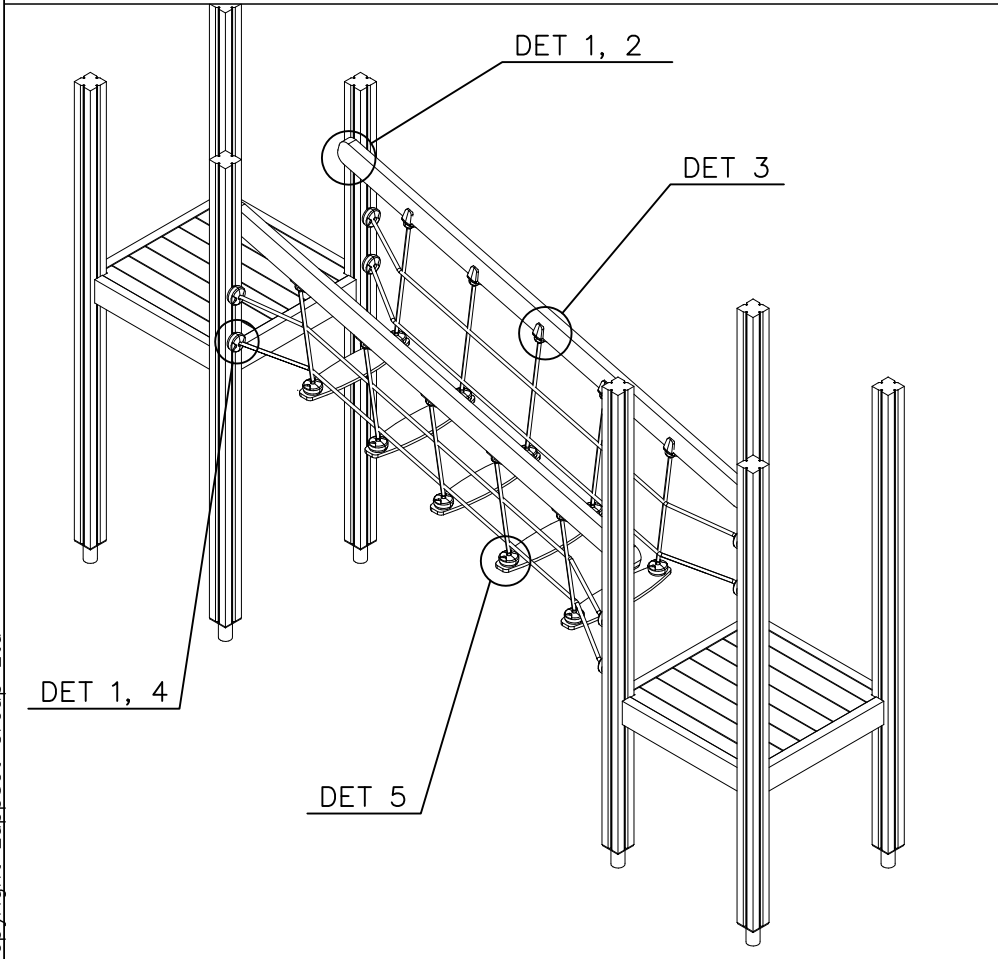

① 706453	PCS	② 707255	PCS
	5		2
15x145x600		45x120x2480	
③ 707260	PCS	④ 905083	PCS
	2		4
2375x600		Ø32	
⑤ 980151	PCS	⑥ 909232	PCS
	4		4
Ø16/8.4		8x120	
⑦ 905112	PCS	⑧ 900240	PCS
	4		16
Ø22		Ø8x70	

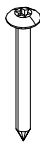

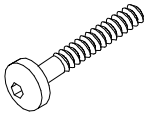
⑨ 980123	PCS	⑩ 980128	PCS
	20		10
Ø7x60		Ø7x40	
⑪ 980150	PCS	⑫ 901899	PCS
	20		20
M8		M8x45	
	PCS		PCS
	PCS		PCS

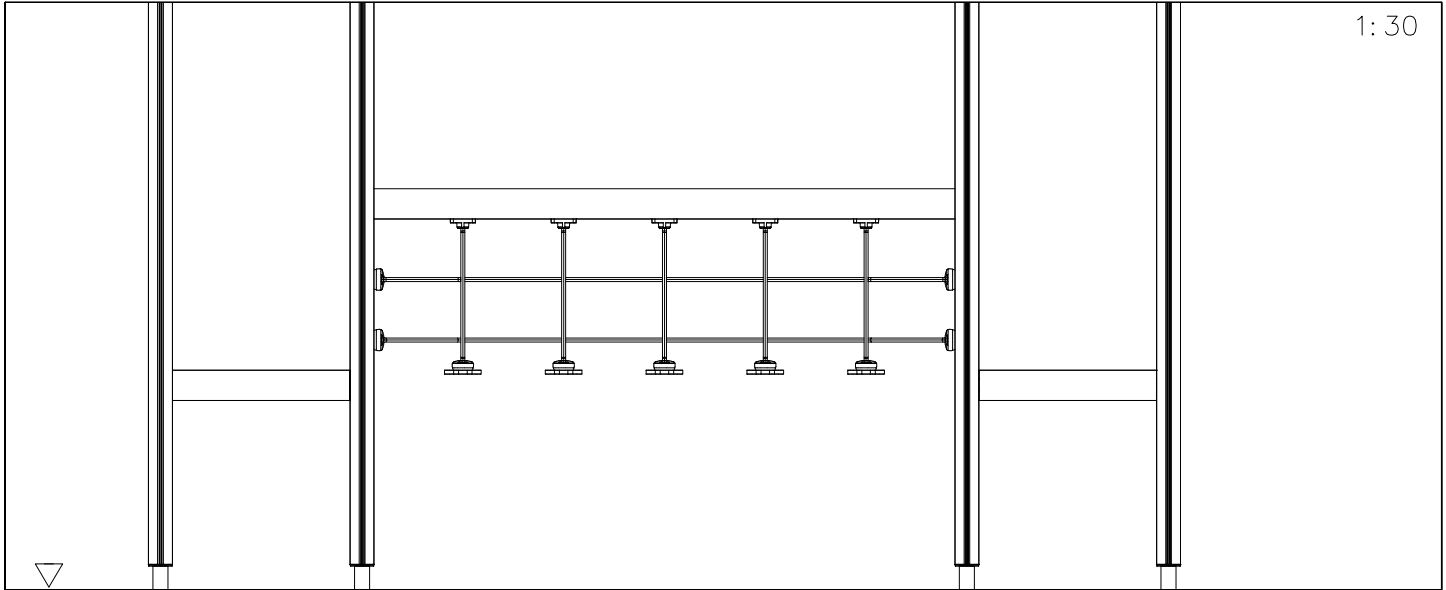

1:30

2400

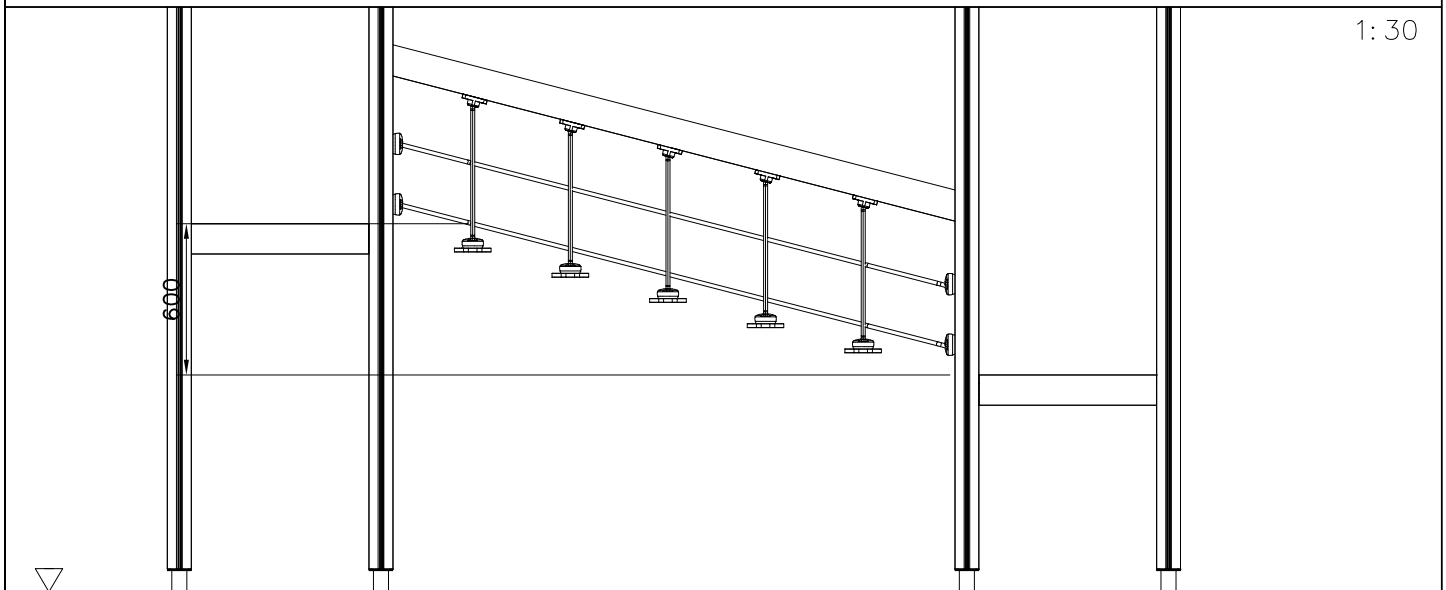

1:30

600

2320

NET OPTIONS

707260

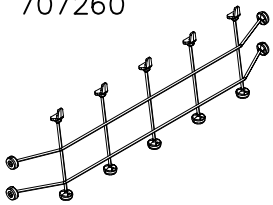

2375x600

- 707260-301 BLUE
- 707260-302 RED
- 707260-303 BEIGE
- 707260-304 GRAY
- 707260-305 BLACK
- 707260-306 YELLOW

RAILING OPTIONS

707255

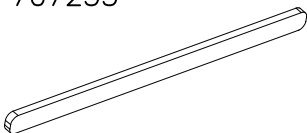

45x120x2480

- | | |
|----------------------|-------------------|
| 707255-605 DARK GRAY | 707255-609 GREEN |
| 707255-606 GRAY | 707255-610 YELLOW |
| 707255-607 RED | 707255-611 LIME |
| 707255-608 BLUE | 707255-612 FUXIA |

DET 1

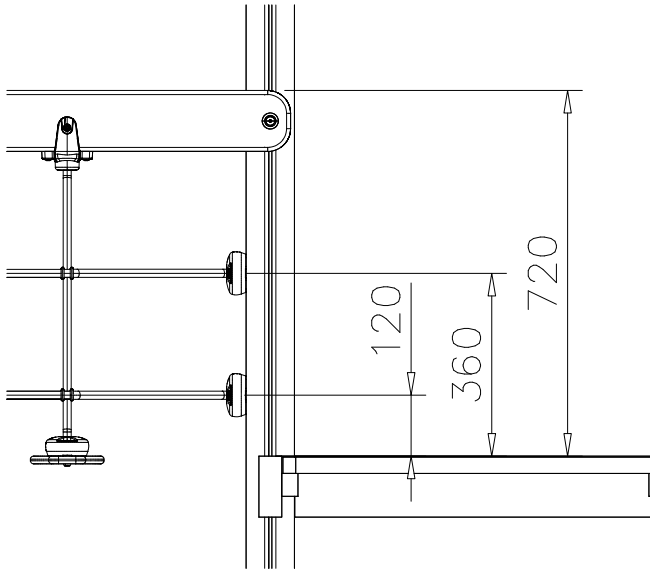

DET 2

Note:
in side
Bridge

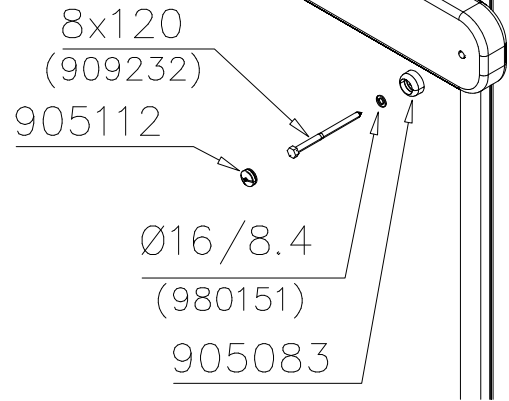

DET 3

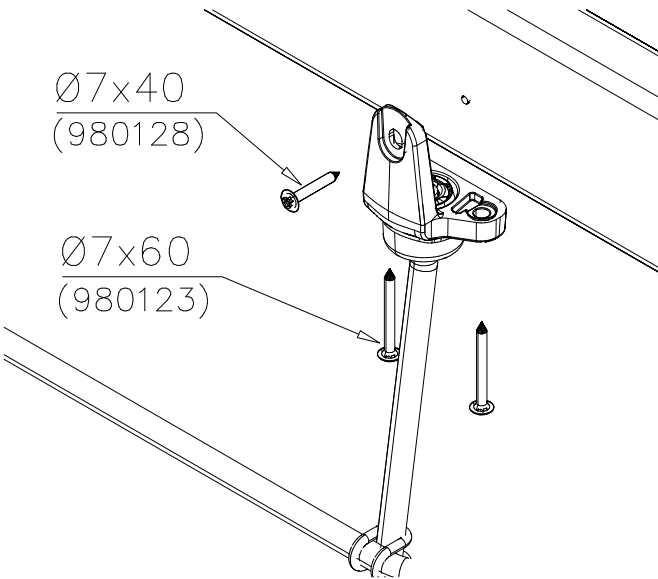

DET 4

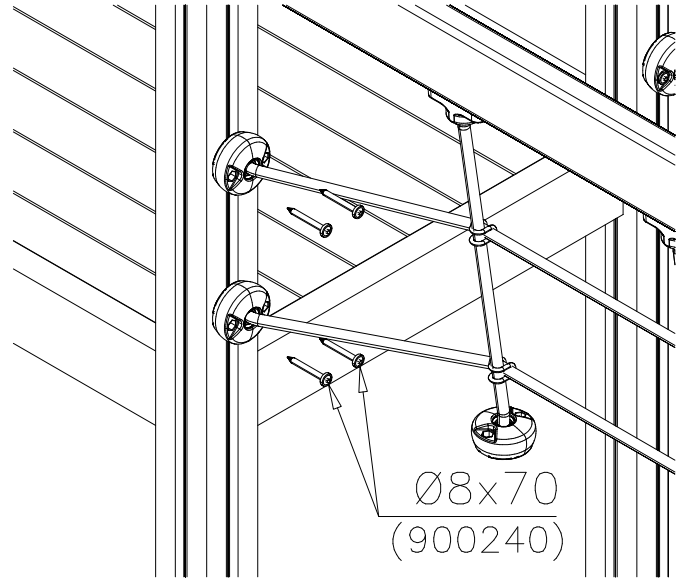

DET 5

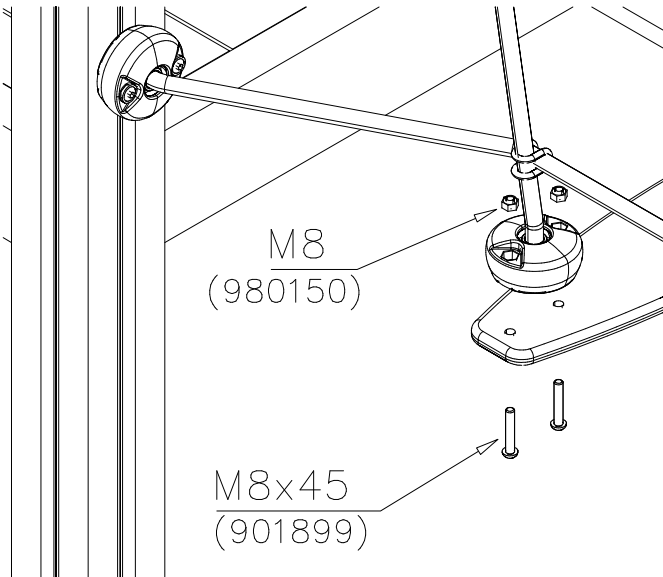

DET 6



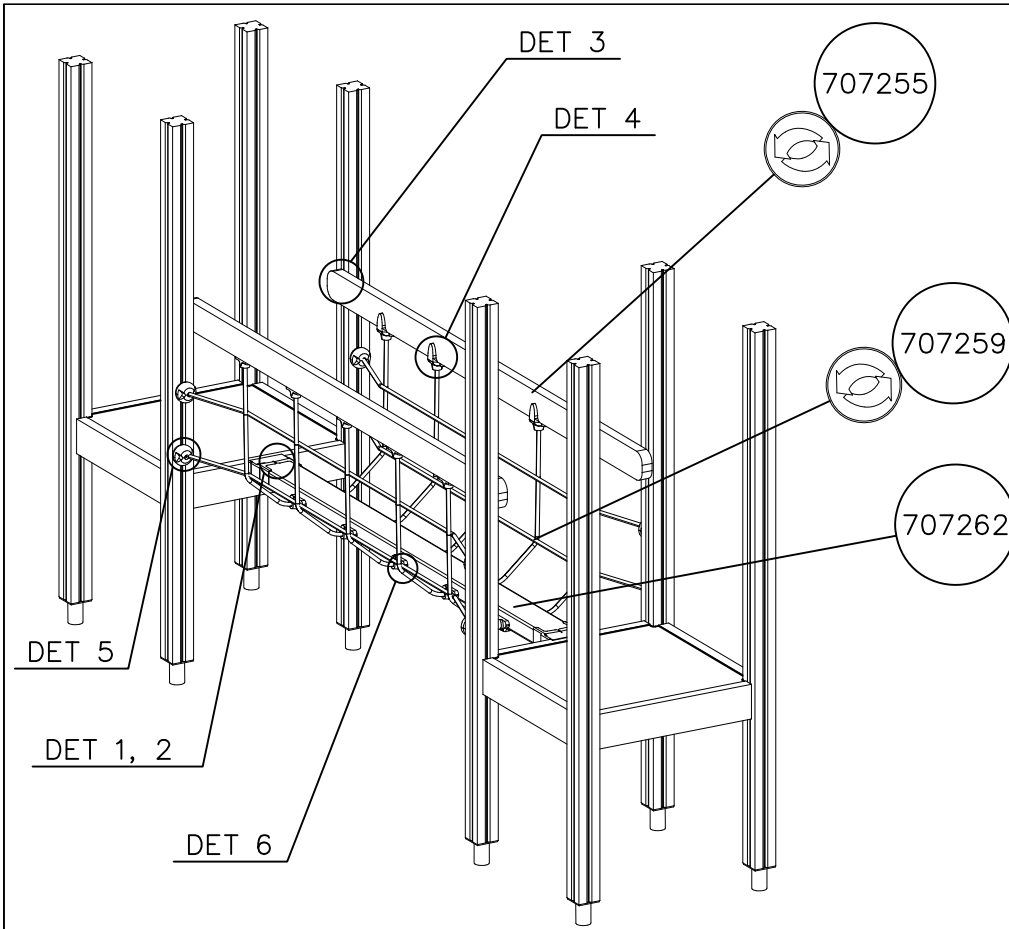

① 707255	PCS	② 707259	PCS
	2		2
45x120x2480		2340x800	
③ 707262	PCS	④ 980123	PCS
	1		40
		Ø7x60	
⑤ 980128	PCS	⑥ 909232	PCS
	28		4
Ø7x40		8x120	
⑦ 900240	PCS	⑧ 980151	PCS
	16		4
8x70		Ø16/8.4	
⑨ 905083	PCS	⑩ 905112	PCS
	4		8
Ø32		Ø22	
	PCS		PCS
	PCS		PCS
	PCS		PCS

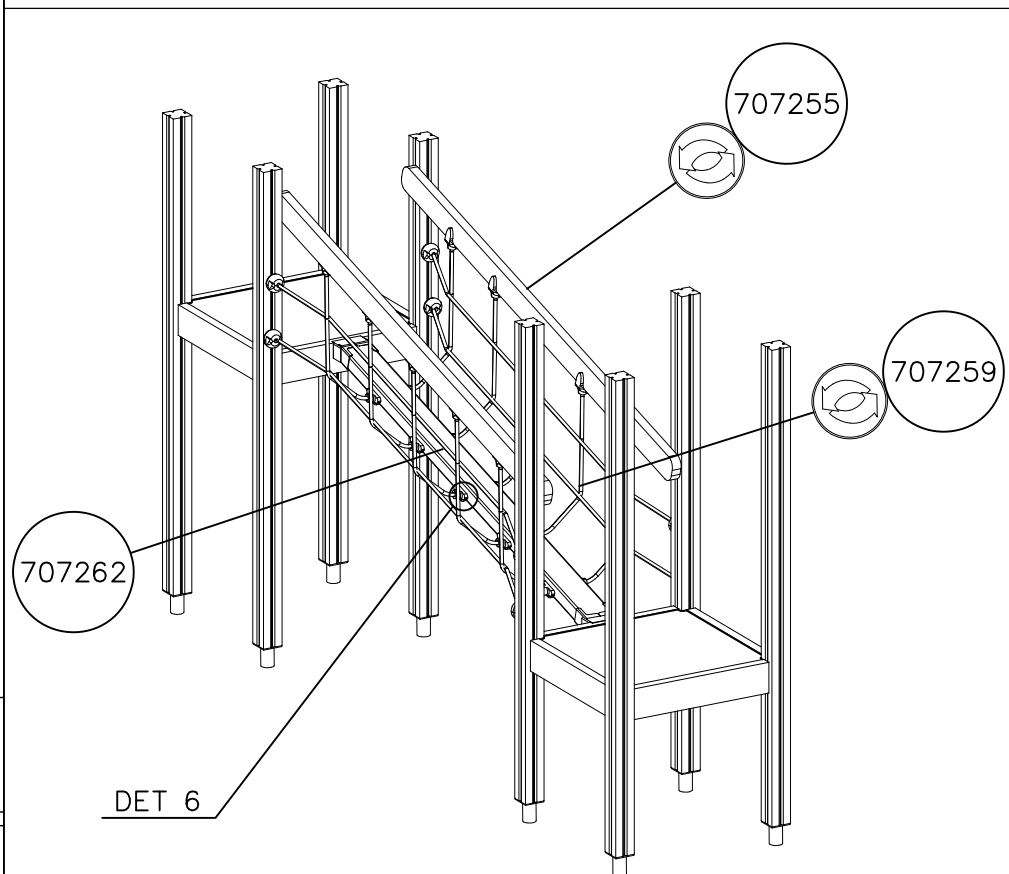

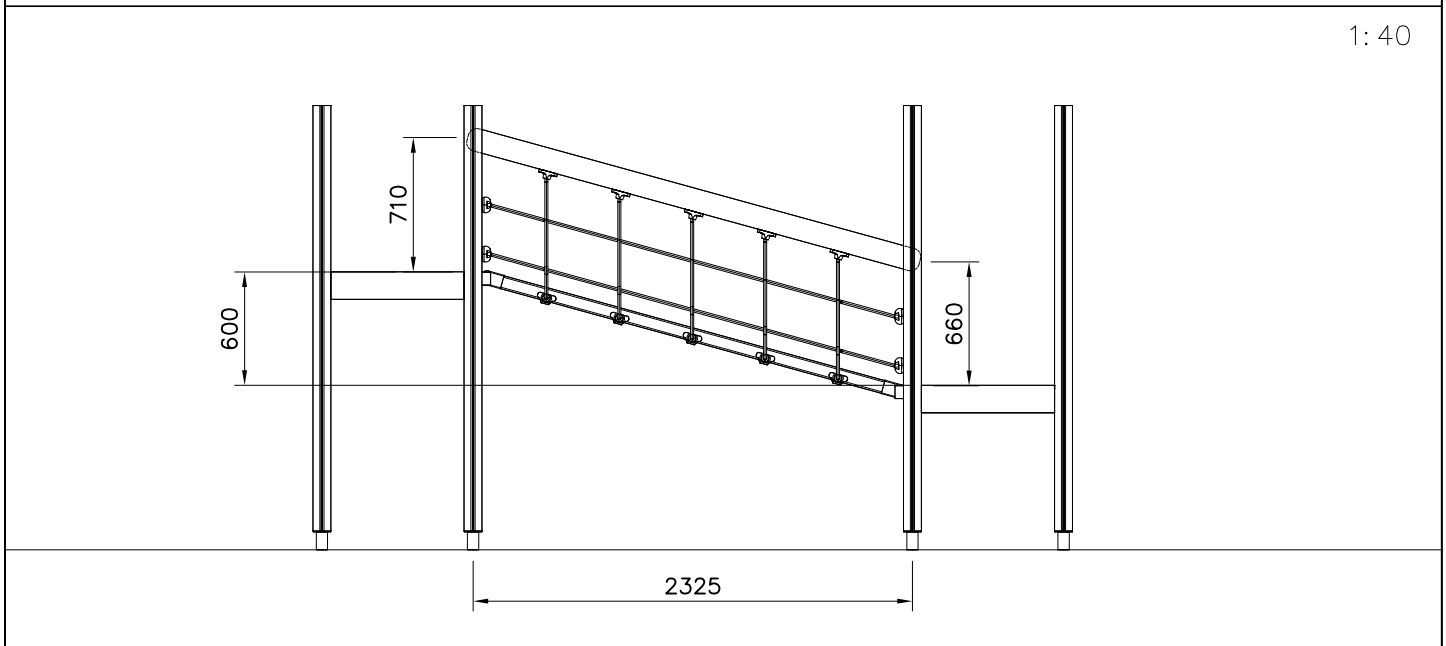
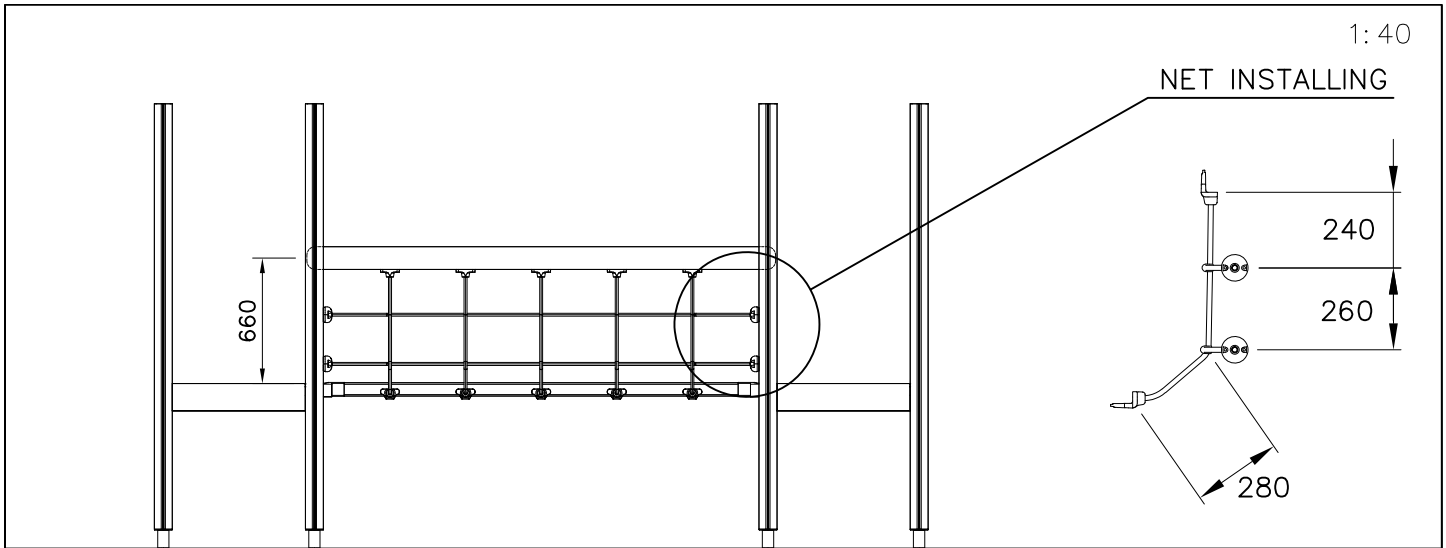

BOOM OPTIONS

707255

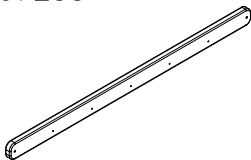

45x120x2480

707255-602	DARK BROWN
707255-603	LIGHT BROWN
707255-604	LIGHT GRAY
707255-605	DARK GRAY
707255-606	GRAY
707255-607	RED

707255-608	BLUE
707255-609	GREEN
707255-610	YELLOW
707255-611	LIME
707255-612	FUXIA

NET OPTIONS

707259

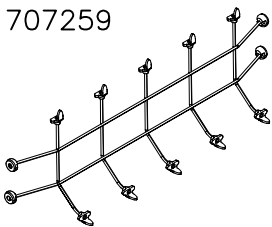

2340x800

707259-301	BLUE
707259-302	RED
707259-303	BEIGE
707259-304	GRAY
707259-305	BLACK
707259-306	YELLOW

DET 1

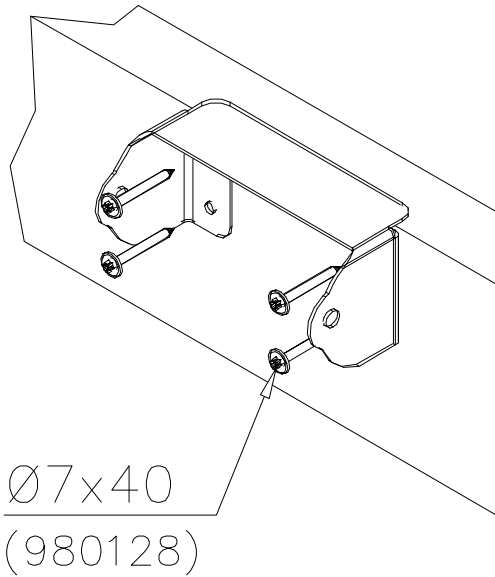

DET 2

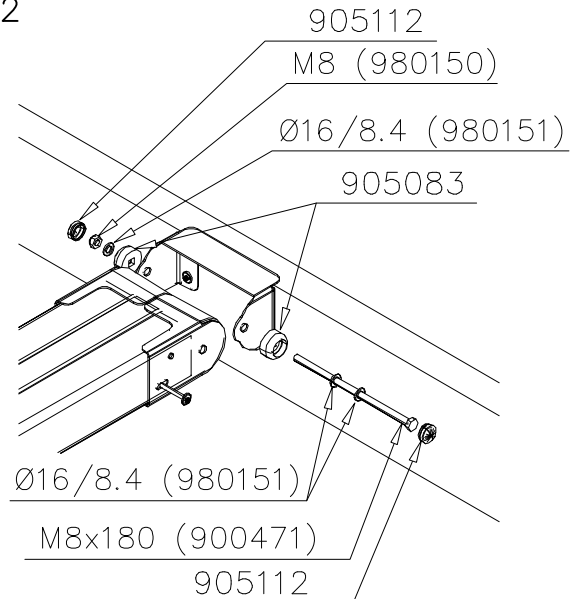

DET 3

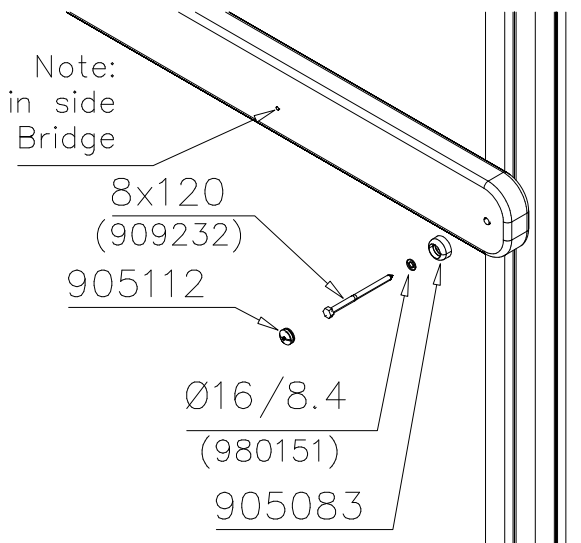

DET 4

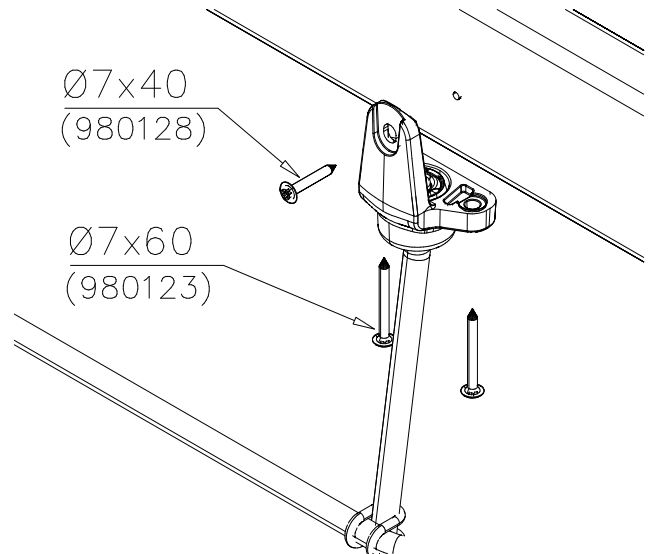

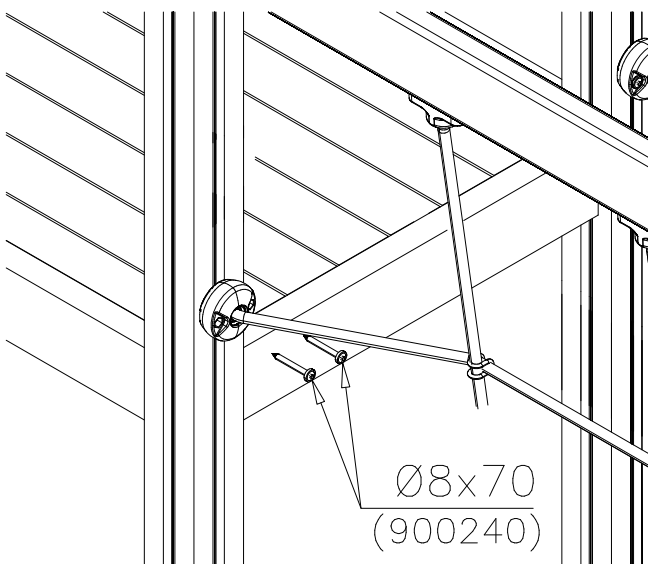

DET 5

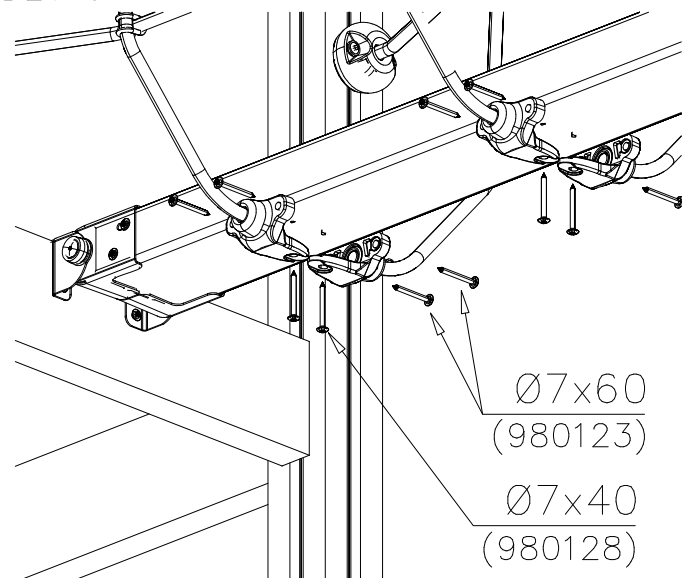

DET 6

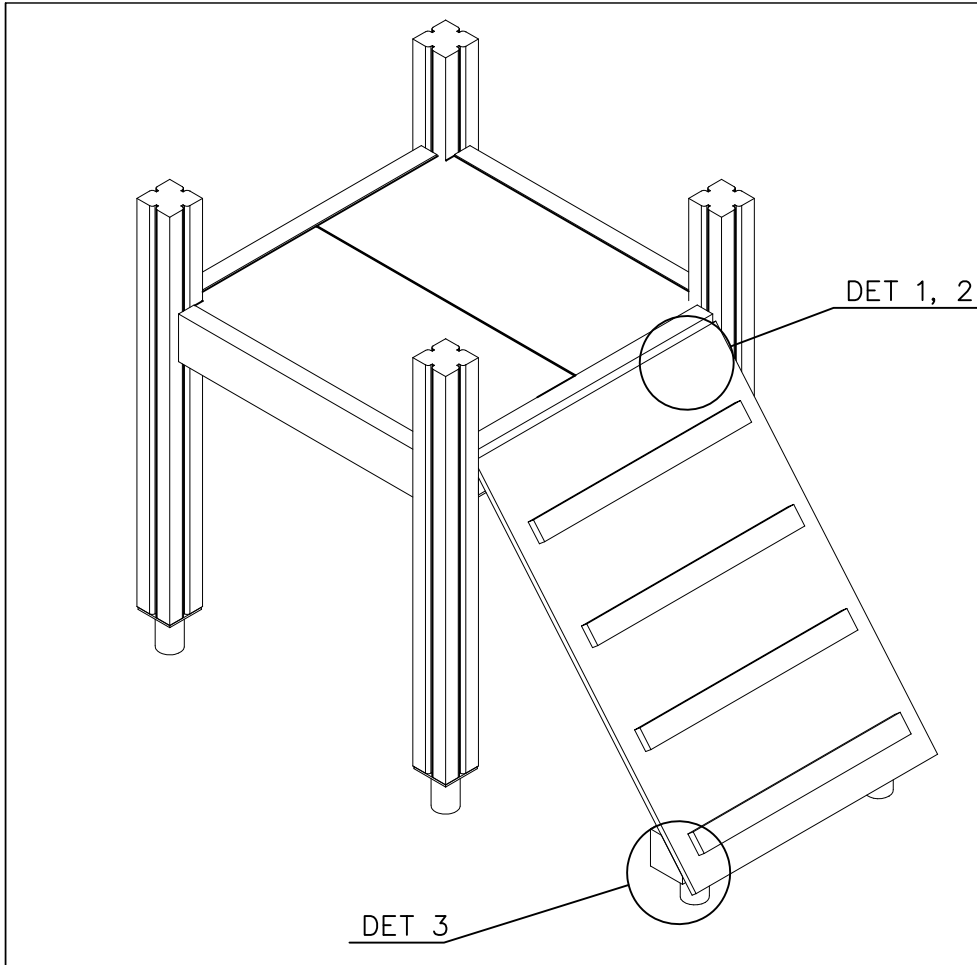

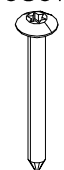
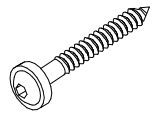

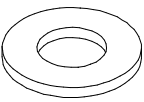
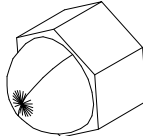
①	980128	PCS	②	900240	PCS
		8			4
Ø7x40			Ø8x70		
③	909852	PCS	④	909256	PCS
		3			7
M8x30			Ø16/8.4x1.6		
⑤	909633	PCS			PCS
		3			
M8					
		PCS			PCS

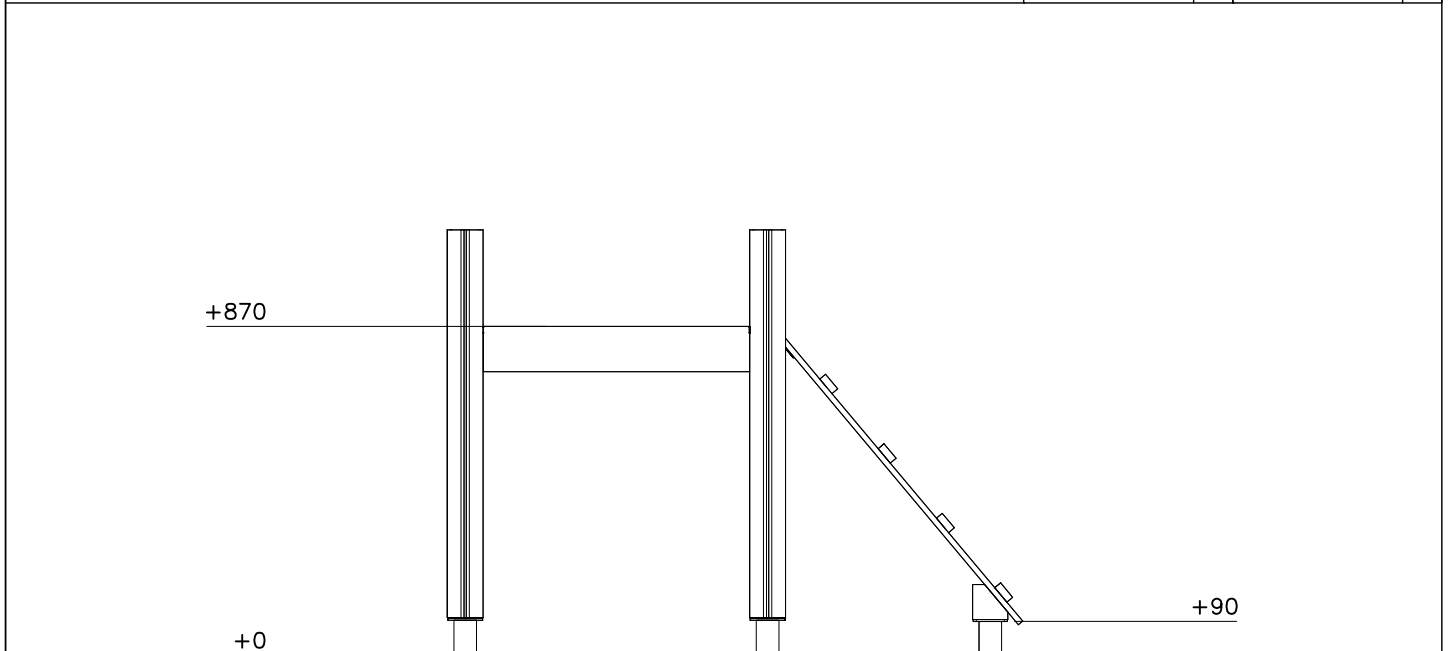

CLIMB OPTIONS

707418

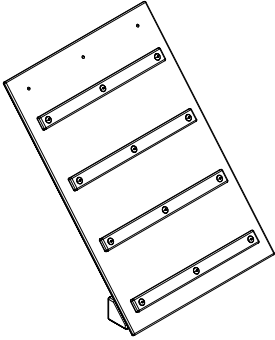

700x1000

707418-701	BLUE
707418-702	YELLOW
707418-703	LIME
707418-704	DARK GREY
707418-705	GREY
707418-706	RED
707418-707	GREEN
707418-708	FUCHSIA

DET 1

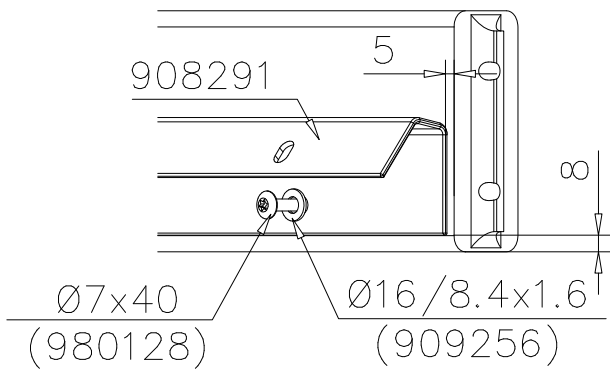

DET 2

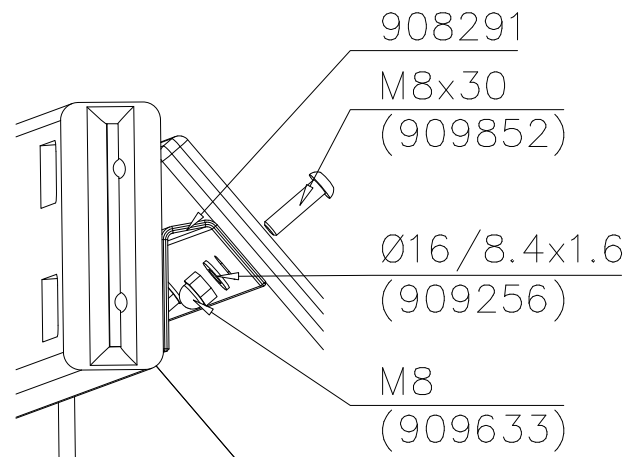

DET 3

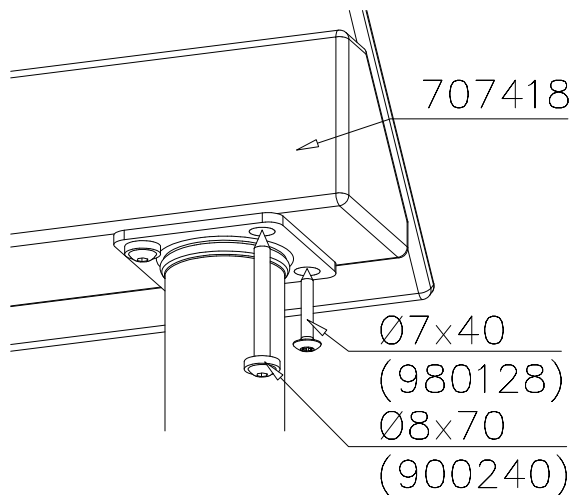



① 900240	PCS	② 900727	PCS
	1		1
Ø8x70		M10x80	
	PCS		PCS
③ 907688	PCS	③ 907701	PCS
	1		1
765		545	
	PCS		PCS
	PCS		PCS
	PCS		PCS
	PCS		PCS



**Tuotekyltti tulee tuotteen mukana yhdellä seuraavista tavoista:****1) Metallinen tuotekyltti ja kiinnitysruuvit**

- Kiinnitä tuotekyltti ruuveilla tolppaan noin 2 metrin korkeuteen kuvan 1 mukaisesti.

2) Tuotekylttitarra

- Puhdista maalattu metalli- tai vaneripinta pölystä ja kosteudesta. Liimaa tarra kuvan 2 mukaisesti.
- Huom. Älä kiinnitä tarraa karheapintaiseen laminaattiin tai maalattuun puuhun.

Vår produktmärkning levereras på ett av följande sätt:**1) Produktskylt i metall**

- Fäst skylten med de medföljande skruvarna

2) Självhäftande produktetikett

- Rengör den pulverlackerade metallytan eller laminatyten så att den blir fri från smuts och fukt. Fäst etiketten enligt fig. 2.
- Obs! Fäst ej etiketten på detaljer med skrovlig yta eller på målat trä.

Product label is delivered by one of following ways:**1) Metal product label and screws**

- Fasten the label with screws.

2) Label sticker

- Clean the painted metal or plywood surface from dirt and moisture. Fasten the sticker as shown in the figure 2.
- Note. Do not attach the sticker to rough surfaced laminate or painted wood.

La plaque d'informations produit est livrée sous l'une de ces 3 formes :**1) Plaque métallique et vis**

- Fixez la plaque à l'aide des vis.

2) Etiquette autocollante

- Avant de coller l'étiquette, nettoyez le composant métallique peint ou la plaque de contreplaqué, de toute saleté. La surface doit être sèche (voir image 2).
- Attention, ne pas coller l'étiquette sur une surface lamellé-collée irrégulière ou sur du bois peint.

Die Auslieferung des Produktaufklebers erfolgt auf eine dieser Arten:**1) Produkt-Schild aus Metall incl. Schrauben**

- Die Befestigung des Schildes erfolgt mittels der Schrauben.

2) Aufkleber

- Entfernen Sie zunächst Schmutz und Feuchtigkeit vom lackierten Metall bzw. von der Holzoberfläche und bringen Sie den Aufkleber wie im Bild oben rechts beschrieben auf den gesäuberten Untergrund auf.
- Beachten Sie: Bringen Sie den Aufkleber nicht auf raues laminiertes oder lackiertes Holz an.

Huom. Pystyttäessä tube- liukumäkeä korkean leikkivälineen yhteyteen, voidaan pystytystyössä tarvita nosturia, ellei paikalla ole tarpeeksi pystytyshenkilökuntaa.

1. Tarkista tuoteosaluettelon ja osiin merkittyjen tuotenumeroiden avulla, että kaikki osat sisältyvät toimitukseen.
2. Valitse välineelle paikka ottaen huomioon valmistajan asennusohjeessa ilmoittamat turvaetäisyydet, 2m turvaetäisyys jarrutuslaatikon edessä ja 1m sivuilla. Tube liukumäen alastuloalueen on vastattava 1m putoamiskorkeutta. Tee tarvittavat peruskaivannot jarrutuslaatikkoa varten.
3. Kokoa kehät sivujen 4 ja 5 mukaisesti huomioiden läpinäkyvät osat.
4. Liitä kehät toisiinsa asennusohjeen numeromerkintöjen mukaan. Sivulla 6 esitetään esimerkki kehien kokoamisesta. Huomioi ettei läpinäkyviä osia tule liukupintaan.
5. Asenna esikoottu lähtölevy putken yläpäähän ohjeen mukaiseen asentoon. Asenna jarrutuslaatikon 905850 perustusraudat asennusohjeen mukaisesti ja liitä putken alapäähän.
6. Nosta putkiliukumäki rakennelmaa vasten ja kiinnitä ohjeen mukaisilla kiinnikkeillä. Täytä jarrutuslaatikon alusta hiekalla.
7. Asenna mahdolliset liukumäen tukitolpat erillisen ohjeen mukaan.
8. Tee käyttöönottotarkastus ennen välineen käyttöönottoa toimitukseen sisältyvän pöytäkirjan mukaisesti. Pöytäkirja tulee dokumentoida. Muista, että pääsy välineeseen tulee estää, kunnes se on valmis, turvallinen ja kaikki asennustarvikkeet on viety pois.

Obs. När du lyfter upp en tuberutschbana mot en hög leku­trustning, kan det hända att du behöver använda en kran om det inte finns monteringspersoner på plats.

1. Kontrollera stycklistan och delarna i förpackningen med hjälp av produktnumren.
2. När du väljer platsen för utrustningen bör du beakta de säkerhetsavstånd som tillverkaren meddelat i monteringsanvisningarna. 2 m säkerhetsavstånd framför bromslådan och 1 m på sidorna. På Tubes- rutschbanan landningsområde måste det finnas motsvarande 1 m fallhöjd. Utför nödvändigt grundarbete för bromslådan.
3. Montera ringarna enligt sidorna 4 och 5 och beakta de genomskinliga delarna.
4. Montera ihop ringarna med varandra enligt numren i monteringsanvisningarna. På sidan 6 får du ett exempel på hur man monterar ringarna. Observera att det inte får komma några genomskinliga delar på glidytan.
5. Sätt fast den förmonterade startskivan på den övre delen enligt anvisningarna. Sätt fast bromslådan i enlighet med monteringsanvisningarna för fundamentjärnen 905850 och sätt fast i den nedre delen av röret.
6. Lyft upp tub­rutschbanan mot konstruktionen och fäst med fästelement enligt anvisningarna. Fyll botten av bromslådan med sand.
7. Montera eventuella stöd­stolpar till rutschbanan enligt separata anvisningar.
8. Innan utrustningen tas i bruk ska en slutbesiktning i enlighet med protokollet i leveransen utföras. Protokollet måste dokumenteras. Kom ihåg att tillträde till utrustningen måste förhindras tills den är färdig monterad, säker och alla monterings­­tillbehör avlägsnats.

Please note! In the absence of sufficient installation staff you may need to use a crane to attach the Tube slide to a tall structure.

1. Use the parts list and the markings on the components to make sure that you have all of the necessary parts.
2. Choose a location for the product, taking into account the safety margins specified in the mounting instructions: leave 2 metres in front of the slide's end and 1 metre on both sides. The curve of the Tube slide must correspond to a total fall height of 1 metre. Prepare the ground for anchoring the end piece.
3. Assemble the tubular components in accordance with the instructions on pages 4 and 5, taking into account the positioning of transparent elements.
4. Join the components together following the numbering in the instructions. An example of how to assemble the tube is shown on page 6. Make sure that none of the transparent elements are used for the sliding surface.
5. Pre-assemble the top deck and position it at the upper end of the slide as shown in the instructions. Fix the steel anchors on the bottom of the slide (part No 905850) into place as instructed and attach to the bottom end of the tube.
6. Lift the tube up against the structure and fix into place using the mountings provided. Fill the area in front of and underneath the slide with sand.
7. Follow the instructions in the supplement to mount support posts if required.
8. Inspect the installation thoroughly using the checklist provided. Document the completed checklist carefully. Remember to stop children from using the product until it has been fully built and safety-tested and all mounting equipment has been cleared away.

Zur Beachtung: Beim Aufstellen der Röhren-Rutschbahn in Verbindung mit einem hohen Spielgerät, ist evtl. für die Aufstellarbeiten ein Kran erforderlich, falls nicht ausreichend Installationspersonal vor Ort verfügbar ist.

1. Überprüfen Sie die Lieferung auf Vollständigkeit, indem Sie das Teileverzeichnis mit der Lieferung abgleichen.
2. Wählen Sie einen Standort für das Gerät entsprechend der vom Hersteller in der Installationsanleitung genannten Sicherheitsabstände, 2 m Sicherheitsabstand vor dem Auslaufstück und 1m zur Seite. Der Auslaufbereich der Röhren-Rutschbahn muss 1m Fallhöhe entsprechen. Führen Sie die nötigen Aushubarbeiten für das Auslaufstück durch.
3. Bauen Sie entsprechend der Seiten 4 und 5 die Ringe unter Berücksichtigung der durchsichtigen Teile zusammen.
4. Verbinden Sie die Ringe entsprechend den in der Montageanleitung genannten Nummernmarkierungen. Auf Seite 6 finden Sie ein Beispiel für das Zusammenfügen der Ringe. Achten Sie darauf, dass keine durchsichtigen Teile auf die Rutschflächen kommen.
5. Befestigen Sie die vormontierte Ablaufplatte in der korrekten Position entsprechend der Anleitung am oberen Ende des Rohres. Montieren Sie die Fundamenteisen nach Anleitung am Auslaufstück 905850 und befestigen Sie es am unteren Ende.
6. Heben Sie die Röhrenrutschbahn an die Konstruktion und befestigen Sie sie mit den Befestigungsteilen entsprechend der Anleitung. Füllen Sie den Untergrund am Auslaufstück mit Sand auf.
7. Montieren Sie eventuelle Stützpfeiler der Rutschbahn nach einer gesonderten Anleitung.
8. Führen Sie eine Inbetriebnahmeüberprüfung entsprechend des im Lieferumfang enthaltenen Protokolls durch, bevor das Gerät benutzt wird. Das Protokoll muss aktenkundig dokumentiert werden. Denken Sie daran, dass der Zugang zum Gerät verhindert werden muss, bis es fertig und sicher ist und alle Installationsgeräte entfernt sind.

N.B. Lorsque le toboggan - tube est monté sur un équipement haut, une grue peut être nécessaire pour les travaux de montage s'il n'y a pas suffisamment de personnel de montage sur place.

1. Vérifier à l'aide de la liste des pièces et des numéros de produit marqués sur les pièces que la livraison comprend toutes les pièces nécessaires.
2. Choisir un bon emplacement pour l'équipement, compte tenu des distances de sécurité indiquées par le fabricant dans les instructions de montage, une distance de sécurité de 2m devant la boîte de freinage et de 1m sur les côtés. La zone de descente du toboggan tube doit correspondre à une hauteur de descente d'un mètre. Effectuer les excavations de base pour la boîte de freinage.
3. Assembler les cadres conformément aux pages 4 et 5 en prenant en considération les pièces transparentes.
4. Relier les cadres les uns aux autres conformément aux numérotations des instructions de montage. Un exemple du montage des cadres est donné à la page 6. Veiller à ce que des pièces transparentes ne soient pas placées sur le côté glissement.
5. Monter la plaque de départ prémontée à l'extrémité supérieure du tube dans la position indiquée dans les instructions. Monter les fers de fondation 905850 de la boîte de freinage conformément aux instructions de montage et les relier à l'extrémité inférieure du tube.
6. Soulever le toboggan- tube contre la structure et le fixer à l'aide des pièces de fixation conformément aux instructions. Remplir le fond de la boîte de freinage avec du sable.
7. Monter les poteaux de support éventuels du toboggan conformément aux instructions séparées.
8. Effectuer un contrôle de mise en service conforme au procès-verbal compris dans la livraison avant la mise en service de l'équipement. Ce procès-verbal doit être documenté. Ne pas oublier d'empêcher l'accès à l'équipement jusqu'à ce que celui-ci soit prêt et sûr et que tous les outils de montage aient été enlevés.

																							
<p>$h < 600$</p> <p>Without movement and therefore without Impact Area</p>	<p>Totally hard surfaces.</p> <p>Note. Lappset does <u>not recommend</u> totally hard surfaces at all.</p>	<p>E.g. concrete or asphalt</p> 																					
<p>$h < 600$</p> <p>With movement e.g. rocking</p>	<p>Materials with very limited impact attenuating properties.</p>	<p>E.g. wood</p> 																					
<p>$h < 1000$</p>	<p>Materials with significant impact attenuating properties.</p>	<p>fine gravel 0–8 mm</p>  <p>grass</p>  <p>unsorted sand</p> 																					
<p>$h < 3000$</p>	<p>Loose fill material</p> <p>E.g. sand/gravel 0,25...8 mm D60/D10<3,0 Woodchips 5...30 mm bark 20...80 mm</p> <p>Syntethic granulates</p> <table border="0"> <tr> <td>\underline{S}</td> <td>$\sim >$</td> <td>\underline{h}</td> </tr> <tr> <td>40 mm</td> <td></td> <td>1,2...1,3 m</td> </tr> <tr> <td>50 mm</td> <td></td> <td>1,5...1,7 m</td> </tr> <tr> <td>60 mm</td> <td></td> <td>1,8...2,0 m</td> </tr> <tr> <td>70 mm</td> <td></td> <td>2,1...2,5 m</td> </tr> </table> <p>Note. For accurate values, see manufacturer's instructions.</p>	\underline{S}	$\sim >$	\underline{h}	40 mm		1,2...1,3 m	50 mm		1,5...1,7 m	60 mm		1,8...2,0 m	70 mm		2,1...2,5 m	 <table border="0"> <tr> <td>\underline{S}</td> <td>\underline{h}</td> </tr> <tr> <td>30 cm</td> <td>$< 2,0$ m</td> </tr> <tr> <td>40 cm</td> <td>$< 3,0$ m</td> </tr> </table> 	\underline{S}	\underline{h}	30 cm	$< 2,0$ m	40 cm	$< 3,0$ m
\underline{S}	$\sim >$	\underline{h}																					
40 mm		1,2...1,3 m																					
50 mm		1,5...1,7 m																					
60 mm		1,8...2,0 m																					
70 mm		2,1...2,5 m																					
\underline{S}	\underline{h}																						
30 cm	$< 2,0$ m																						
40 cm	$< 3,0$ m																						

REMOVE SAFETY SURFACE/SAND/GRAVEL
TO CHECK FOUNDATION



REMOVE SAFETY SURFACE/SAND/GRAVEL
TO CHECK FOUNDATION

