

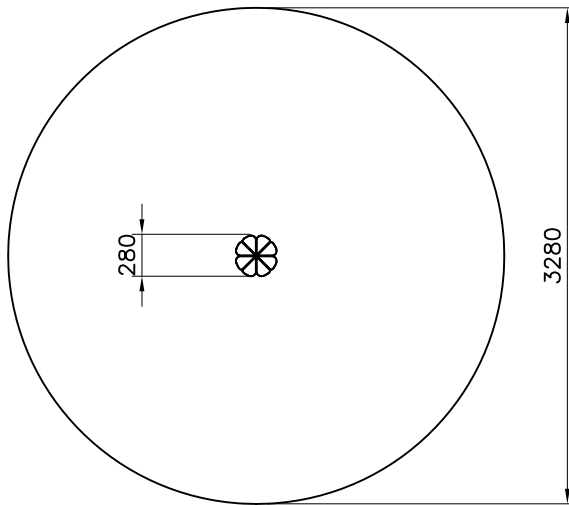

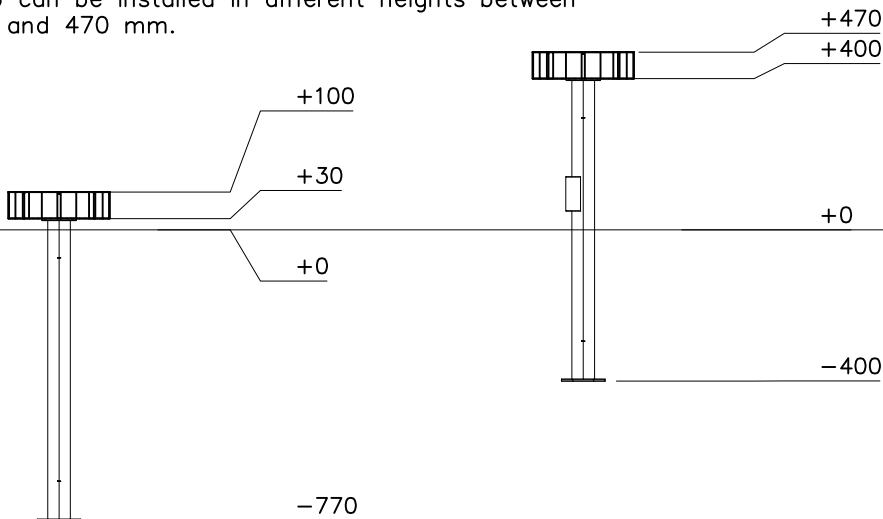

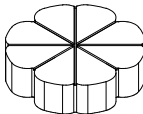

Falling Space 8.4 m²
Max Falling Height 100–470 mm







Step can be installed in different heights between 100 and 470 mm.

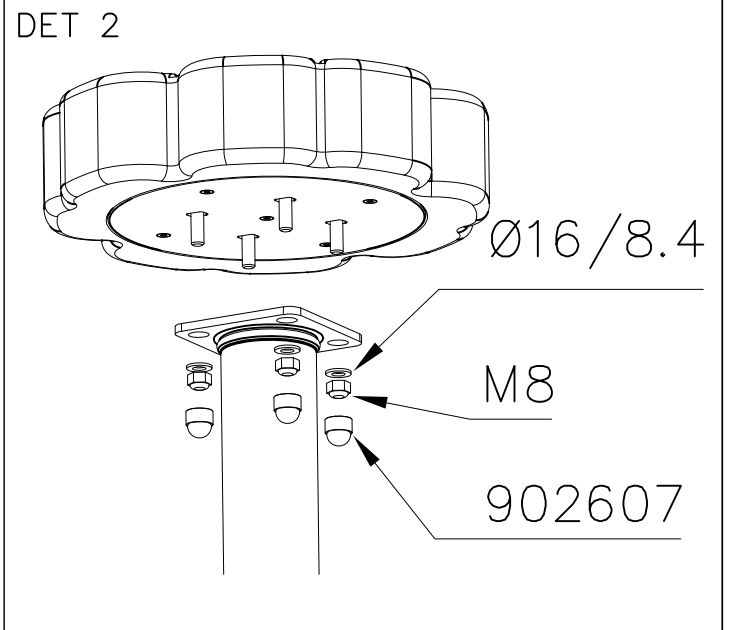
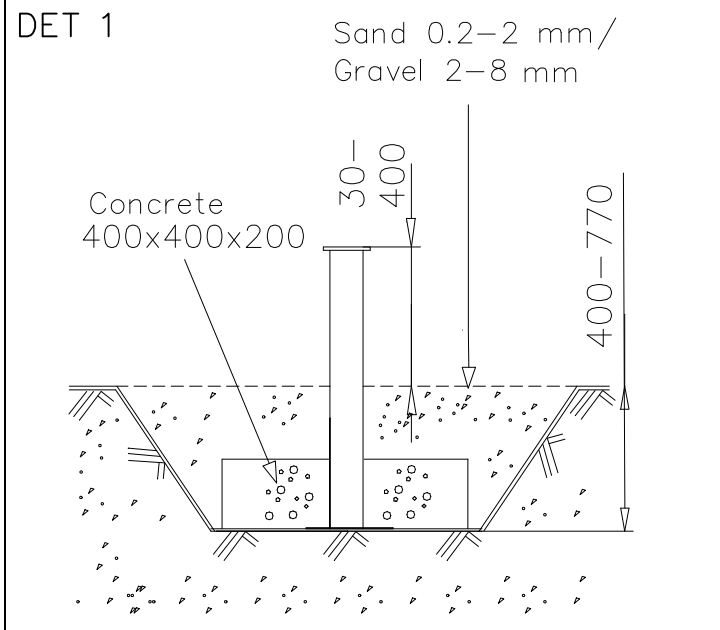

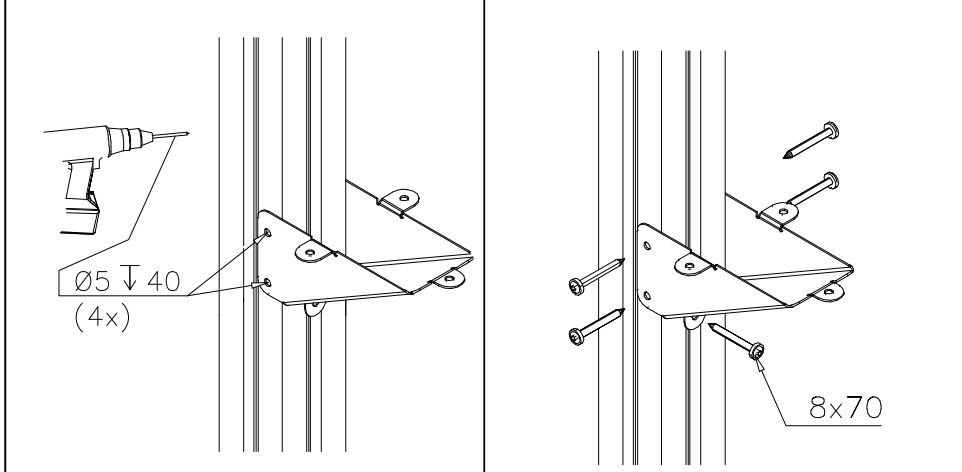
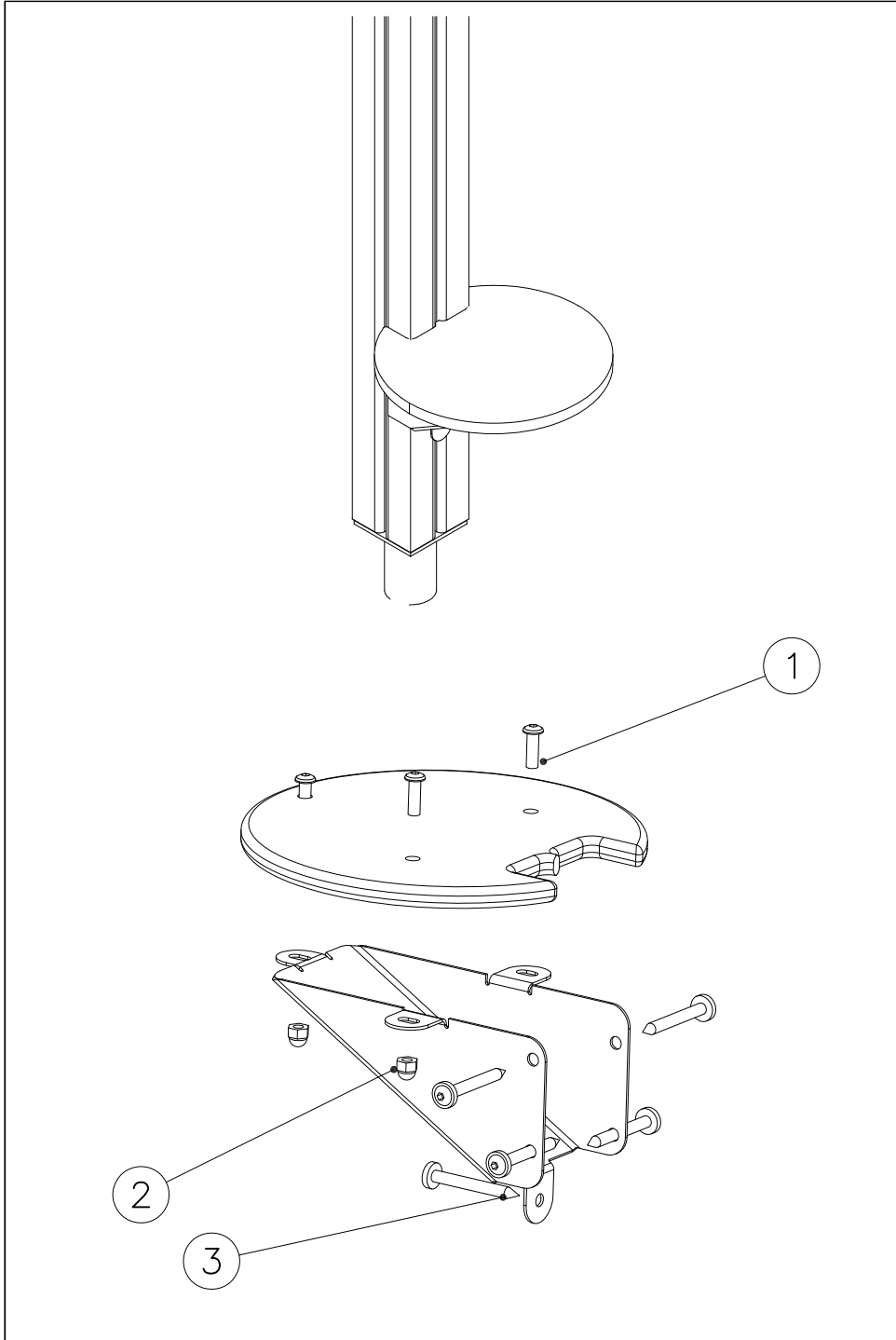
① 708816	PCS	② 909256	PCS
	1		4
		Ø16/8.4	
③ 903441	PCS	④ 980160	PCS
	1		4
115x115x800		M8	
⑤ 902607	PCS	⑥ 702341	PCS
	4		1
M8			
	PCS		PCS
	PCS		PCS
	PCS		PCS
	PCS		PCS
	PCS		PCS



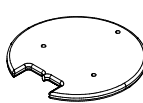
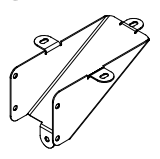

①	909850	PCS	②	909633	PCS
		3			3
	M8x25			M8	
③	900240	PCS			PCS
		5			
	Ø8x70				
		PCS			PCS
○	707696	PCS	○	902086	PCS
		1			1
	15x265x275			148x172x254	
		PCS			PCS
		PCS			PCS
		PCS			PCS
		PCS			PCS

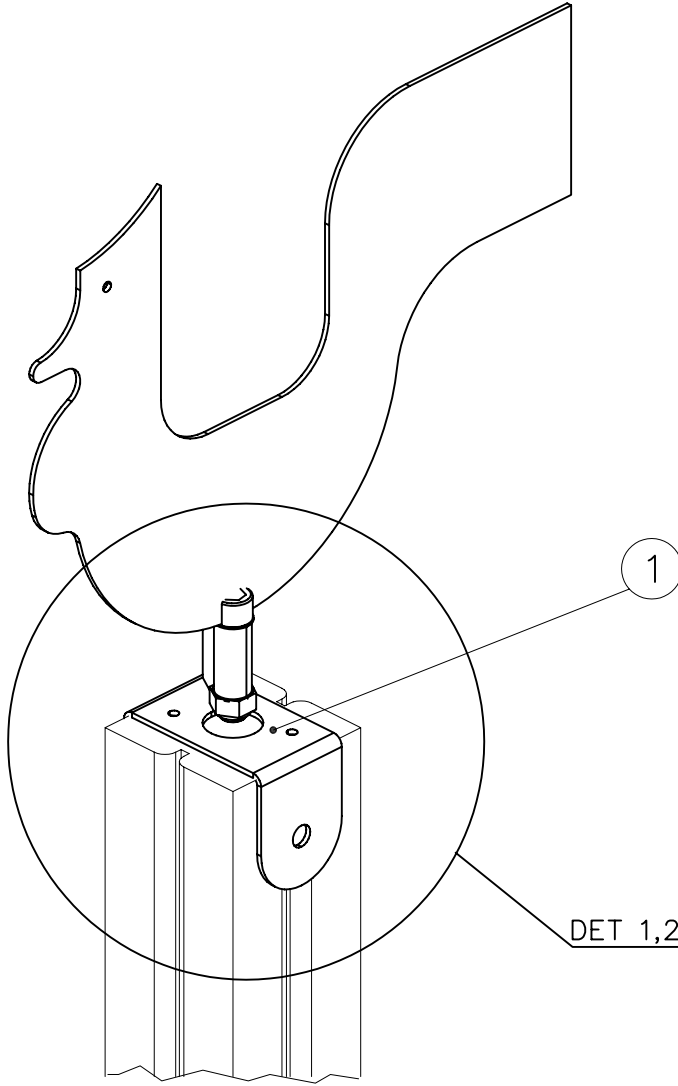

① 907082	PCS 1	② 900240	PCS 2
		Ø8x70	
③ 980106	PCS 2		PCS
5x40			
	PCS		PCS
	PCS		PCS
	PCS		PCS
○ 007120	PCS 1	○ 007121	PCS 1
○ 007122	PCS 1	○ 007123	PCS 1
○ 007124	PCS 1	○ 007125	PCS 1

DET 1

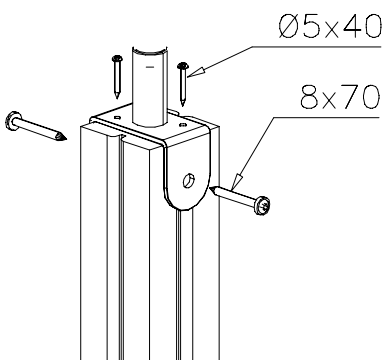

DET 2

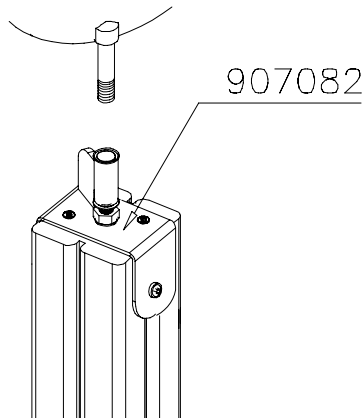



Tuotekyltti tulee tuotteen mukana yhdellä seuraavista tavoista:

1) Metallinen tuotekyltti ja kiinnitysruuvit

- Kiinnitä tuotekyltti ruuveilla tolppaan noin 2 metrin korkeuteen kuvan 1 mukaisesti.

2) Tuotekylttitarra

- Puhdista maalattu metalli- tai vaneripinta pölystä ja kosteudesta. Liimaa tarra kuvan 2 mukaisesti.
- Huom. Älä kiinnitä tarraa karheapintaiseen laminaattiin tai maalattuun puuhun.

Vår produktmärkning levereras på ett av följande sätt:

1) Produktskylt i metall

- Fäst skylten med de medföljande skruvarna

2) Självhäftande produktetikett

- Rengör den pulverlackerade metallytan eller laminatyten så att den blir fri från smuts och fukt. Fäst etiketten enligt fig. 2.
- Obs! Fäst ej etiketten på detaljer med skrovlig yta eller på målat trä.

Product label is delivered by one of following ways:

1) Metal product label and screws

- Fasten the label with screws.

2) Label sticker

- Clean the painted metal or plywood surface from dirt and moisture. Fasten the sticker as shown in the figure 2.
- Note. Do not attach the sticker to rough surfaced laminate or painted wood.

La plaque d'informations produit est livrée sous l'une de ces 3 formes :

1) Plaque métallique et vis

- Fixez la plaque à l'aide des vis.

2) Etiquette autocollante

- Avant de coller l'étiquette, nettoyez le composant métallique peint ou la plaque de contreplaqué, de toute saleté. La surface doit être sèche (voir image 2).
- Attention, ne pas coller l'étiquette sur une surface lamellé-collée irrégulière ou sur du bois peint.

Die Auslieferung des Produktaufklebers erfolgt auf eine dieser Arten:





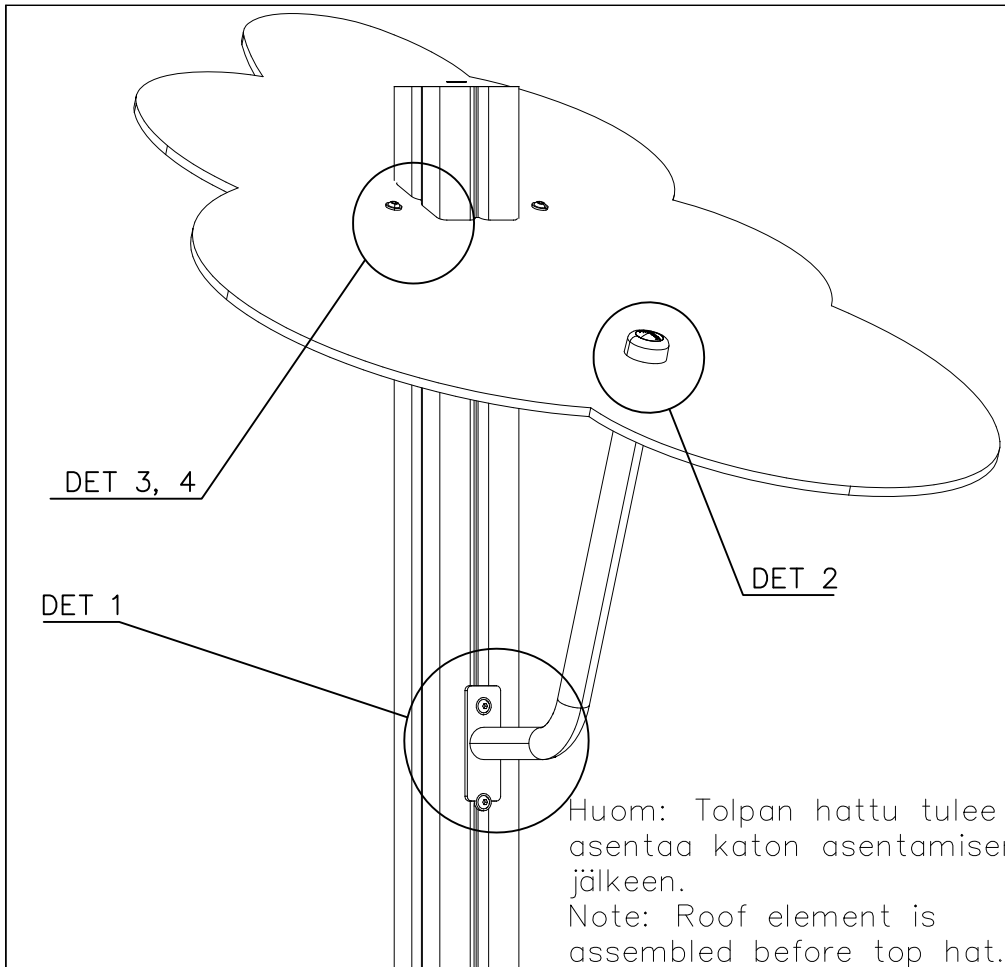

1) Produkt-Schild aus Metall incl. Schrauben

- Die Befestigung des Schildes erfolgt mittels der Schrauben.

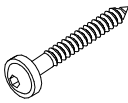
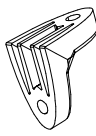
2) Aufkleber

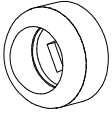
- Entfernen Sie zunächst Schmutz und Feuchtigkeit vom lackierten Metall bzw. von der Holzoberfläche und bringen Sie den Aufkleber wie im Bild oben rechts beschrieben auf den gesäuberten Untergrund auf.
- Beachten Sie: Bringen Sie den Aufkleber nicht auf raues laminiertes oder lackiertes Holz an.

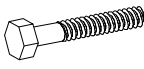

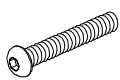
①	900240	PCS	②	901570	PCS
		4			2
	Ø8x70		36x55x55		
③	980154	PCS	④	905086	PCS
		1			1
	Ø24/13		Ø44/13,5		
⑤	905090	PCS	⑥	905115	PCS
		1			1
	Ø45		Ø30		
⑦	909142	PCS	⑧	980160	PCS
		1			2
	M12x70		M8		
⑨	909852	PCS			PCS
		2			
	M8x30				
		PCS			PCS

DET 1

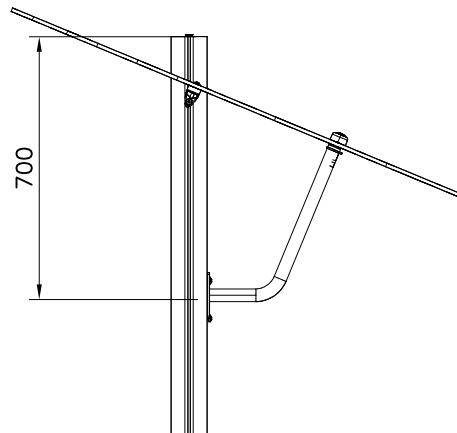
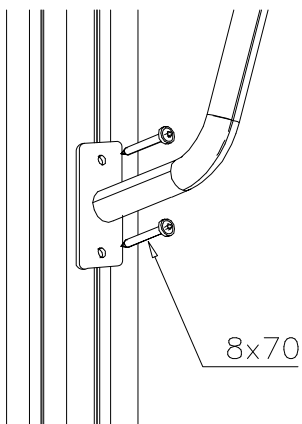

DET 2

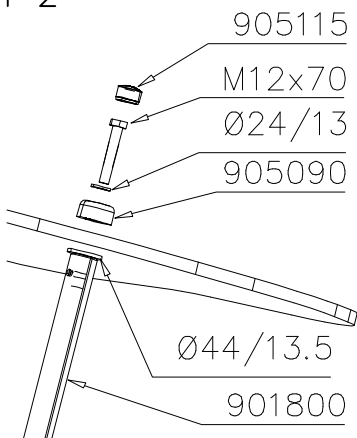

DET 3

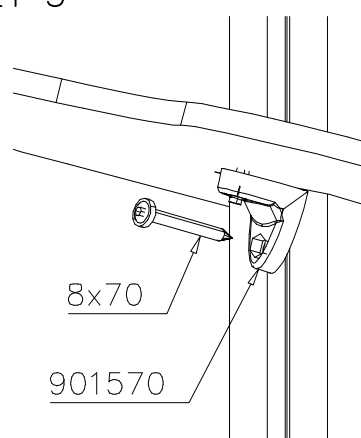

DET 4

