

LAPPSET®

FINNO







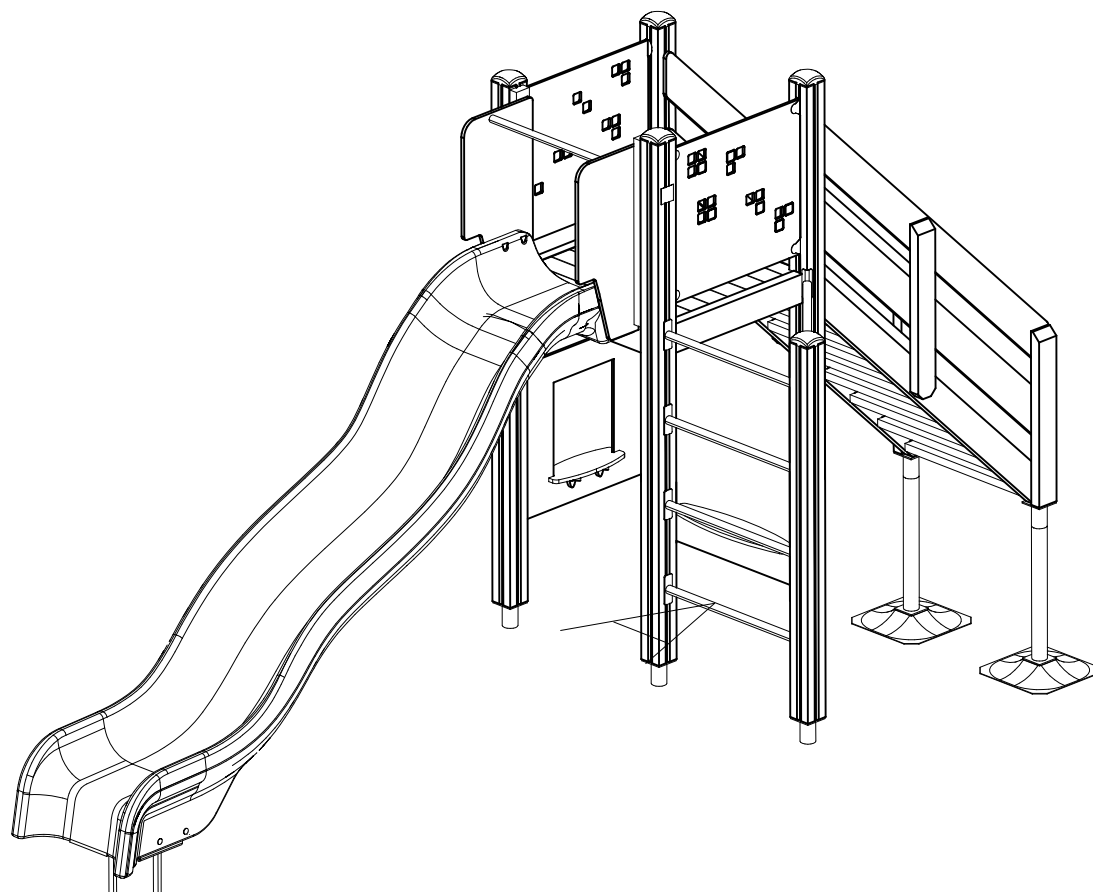

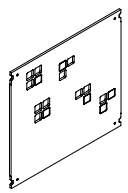
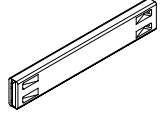

ASENNUSOHJE
MONTERINGSANSVISNING
INSTALLATION INSTRUCTION
AUFBAUANLEITUNG
NOTICE D'INSTALLATION

DATE: 31.8.2016

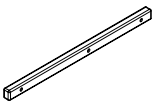
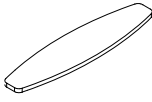
Q10016

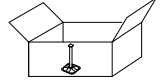
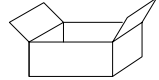
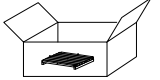

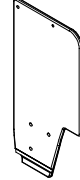
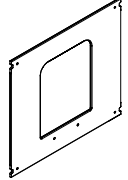
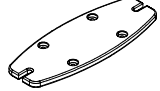
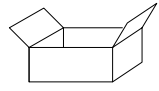
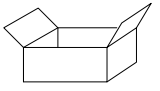
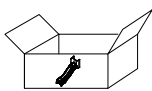
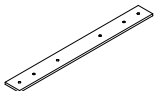
DATE: 12.11.2015

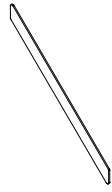
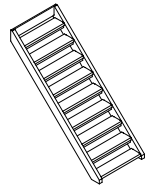
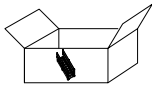
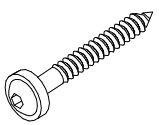
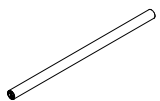
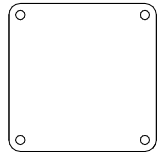
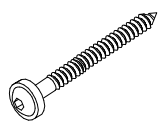
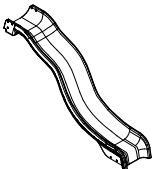
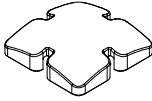
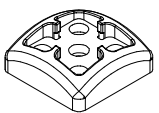
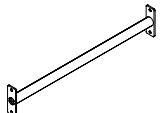
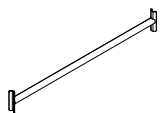
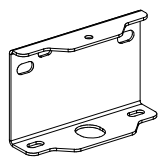
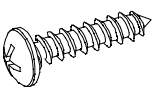
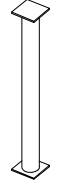
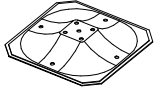
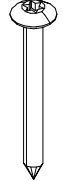
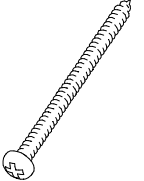
008986  750x750	PCS 1	702286  90x50	PCS 1	706436-703  10x640x702	PCS 3	706439-602  L 704	PCS 5	706441-602  93x93x1550	PCS 1	706443  32x45x702	PCS 2
706453  15x145x600	PCS 1	706484-602  93x93x2150	PCS 4	706505  35x70x730	PCS 2	706531  706531	PCS 7	706534  706534	PCS 3	706535  706535	PCS 1
706560-703  15x765x370	PCS 1	706561-703  15x765x370	PCS 1	706727  10x702x640	PCS 1	706744  15x145x380	PCS 1	706881  706881	PCS 1	706885  706885	PCS 1
706980  SLIDE 80M	PCS 1	707133  10x80x745	PCS 1	707145-602  43x93x717	PCS 2	707149-602  43x93x717	PCS 2	707152-703  15x145x2009	PCS 4	707192-602  +1470	PCS 1
707226  707226	PCS 1	900240  Ø8x70	PCS 32	901868  Ø30x598	PCS 3	902487  65x65	PCS 1	903093  Ø8x90	PCS 20	904451  +1470	PCS 1
905138  GRAY	PCS 5	905196  GRAY	PCS 5	907694-216  L 704	PCS 4	907920-216  DIAG.	PCS 4	908021  3x212x214	PCS 2	909506  Ø3.5x13	PCS 4
909511  90x90x650	PCS 7	909519  50x380x380	PCS 7	980123  Ø7x60	PCS 4	980131  Ø6x60	PCS 20		PCS		PCS

- EN/AS Impact Area 27.4 m²
- - - Falling Space 29.6 m²
- Max Falling Height 1470 mm

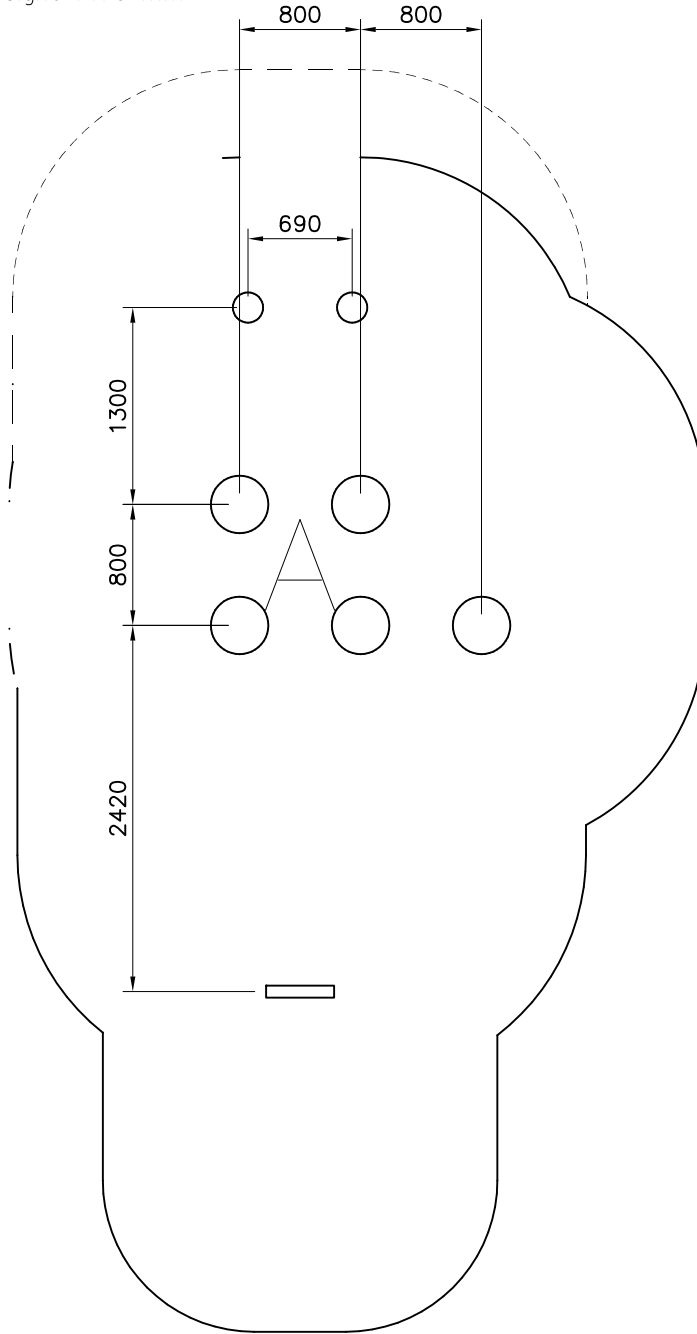
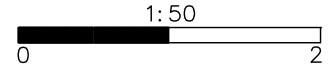

— EN/AS Impact Area 27.4 m²
- - - Falling Space 29.6 m²
Max Falling Height 1470 mm

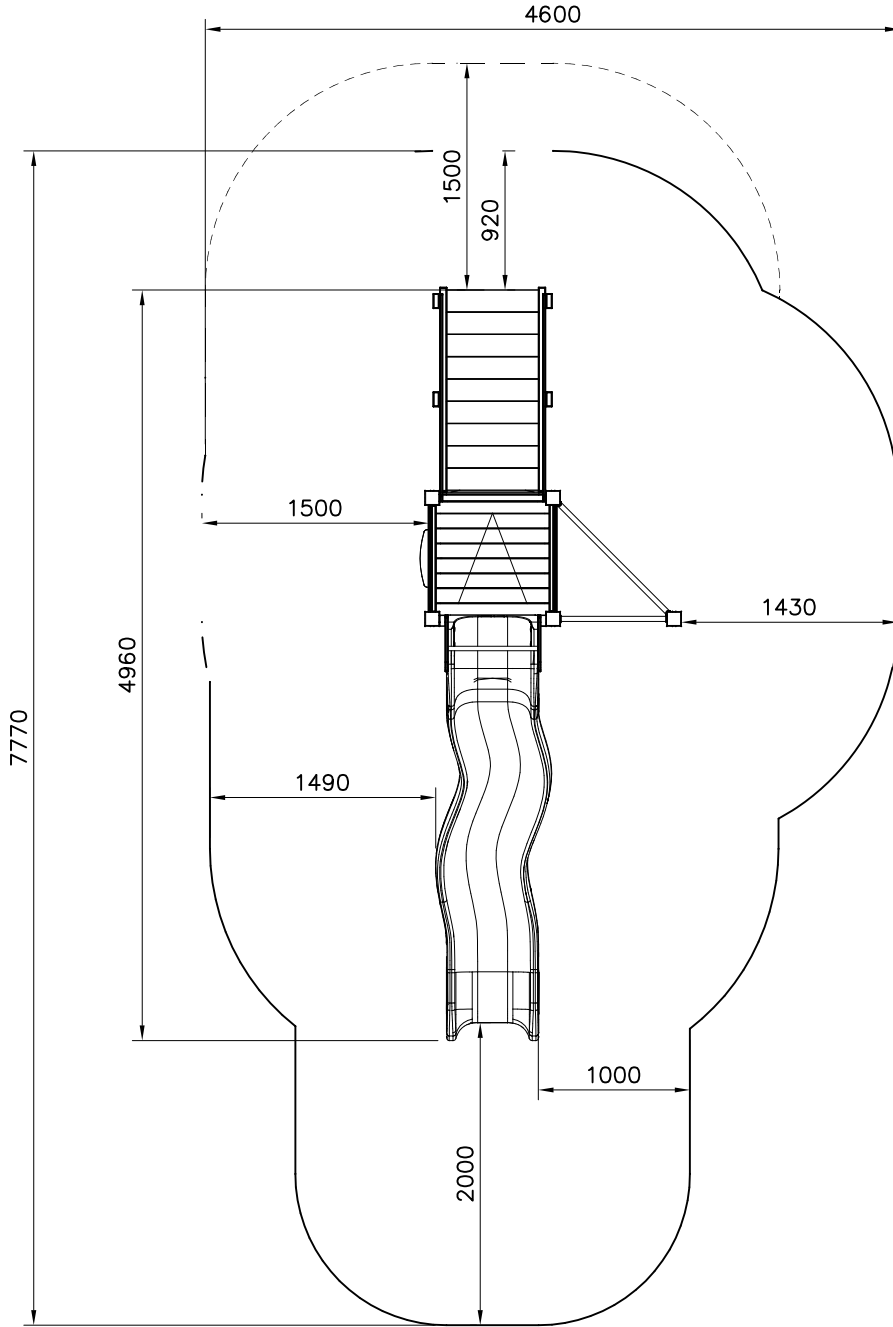
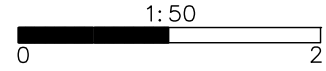

1: 40

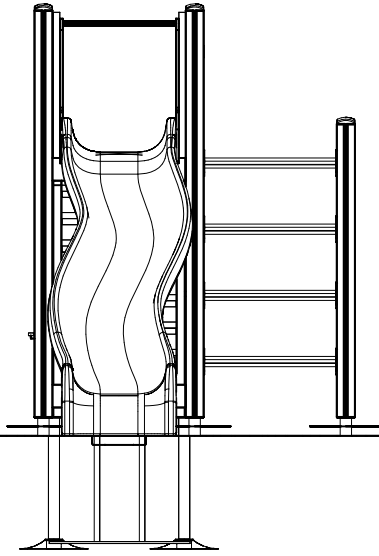

1: 40

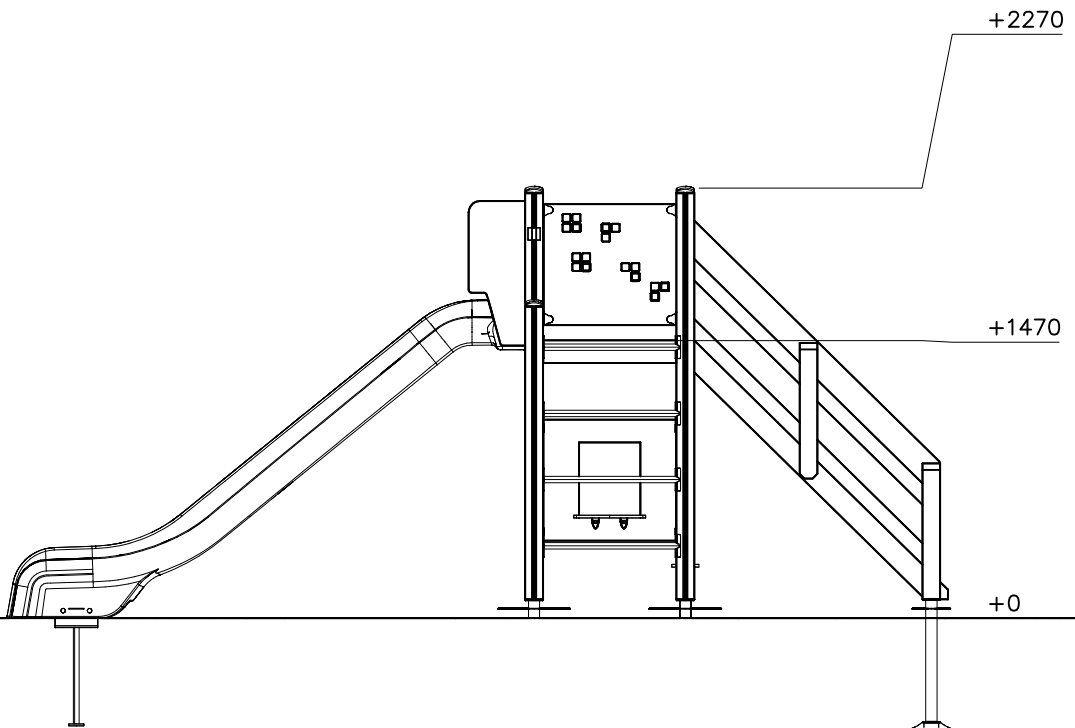

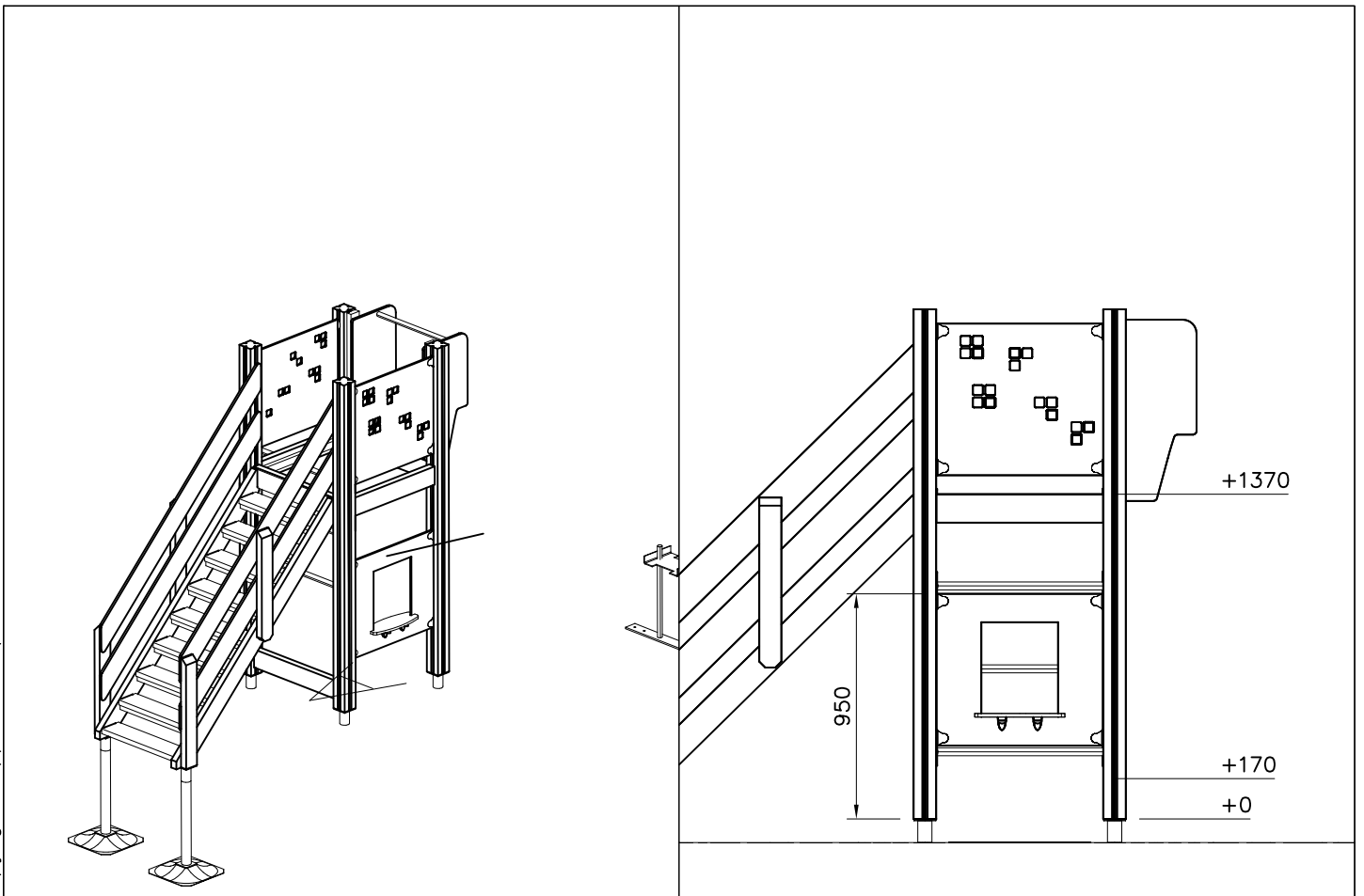
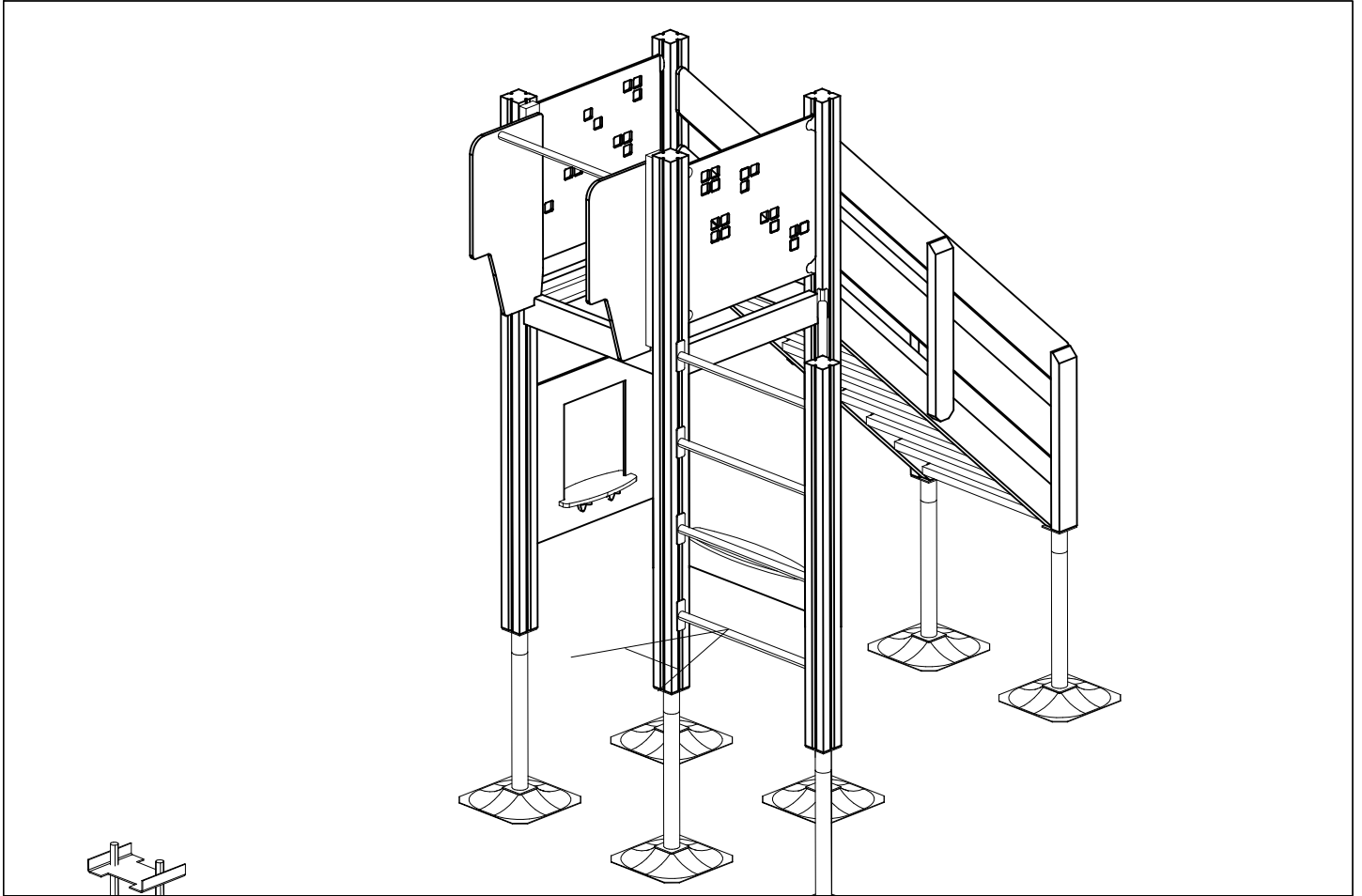

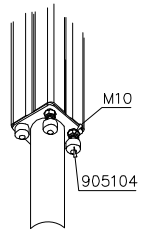
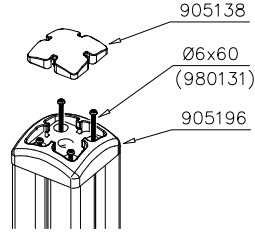
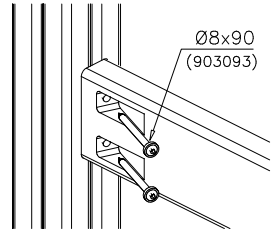
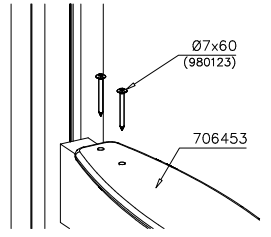
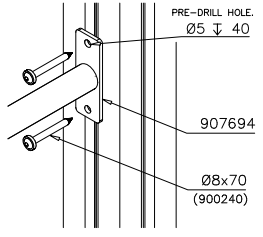
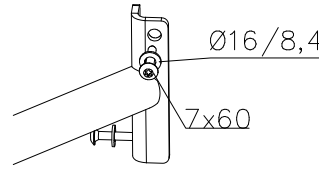
<p>DET 1</p> 	<p>DET 2</p> 	<p>DET 3</p> 	<p>DET 4</p> 
<p>DET 5</p> 	<p>DET 6</p> 		

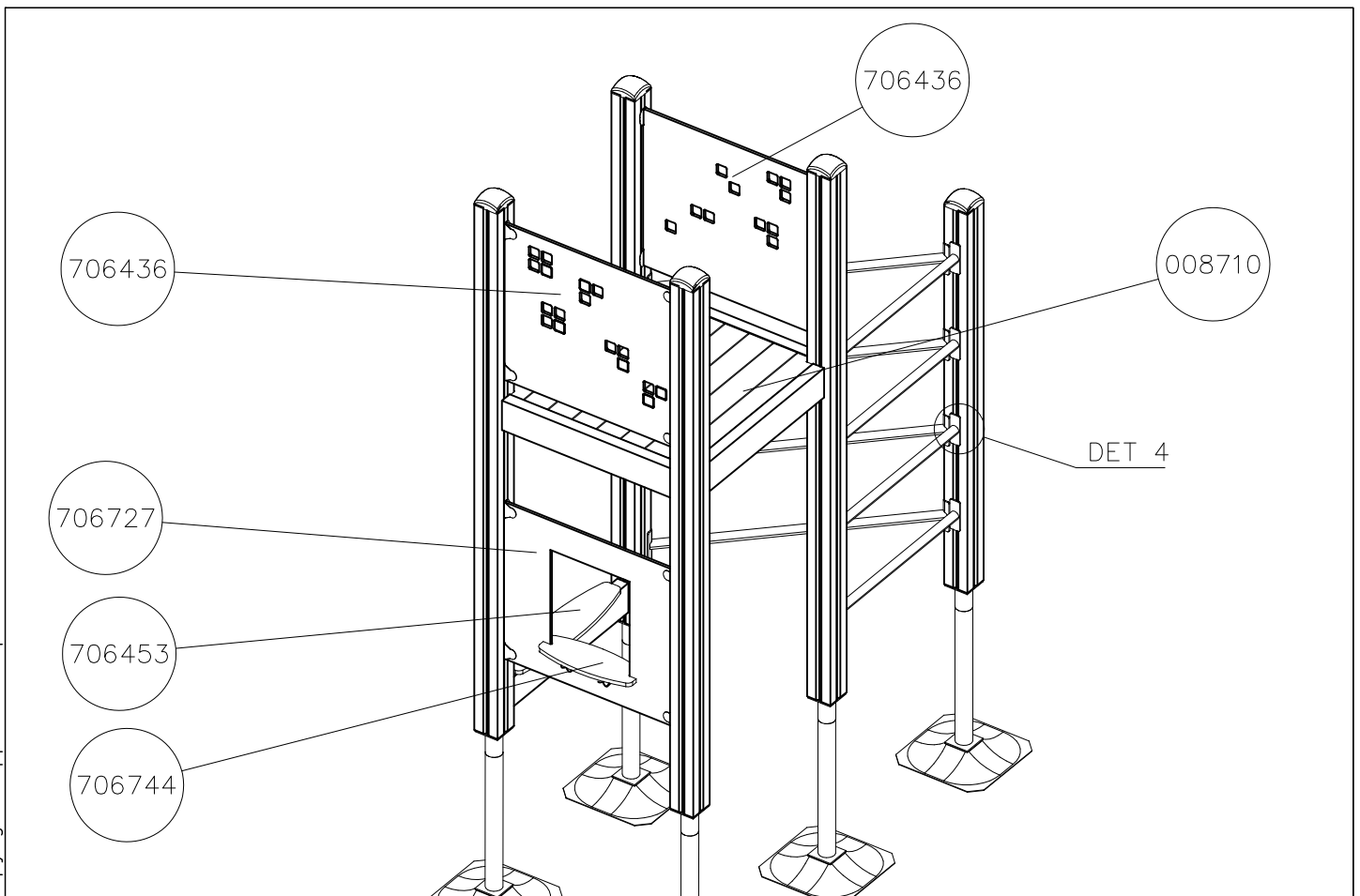
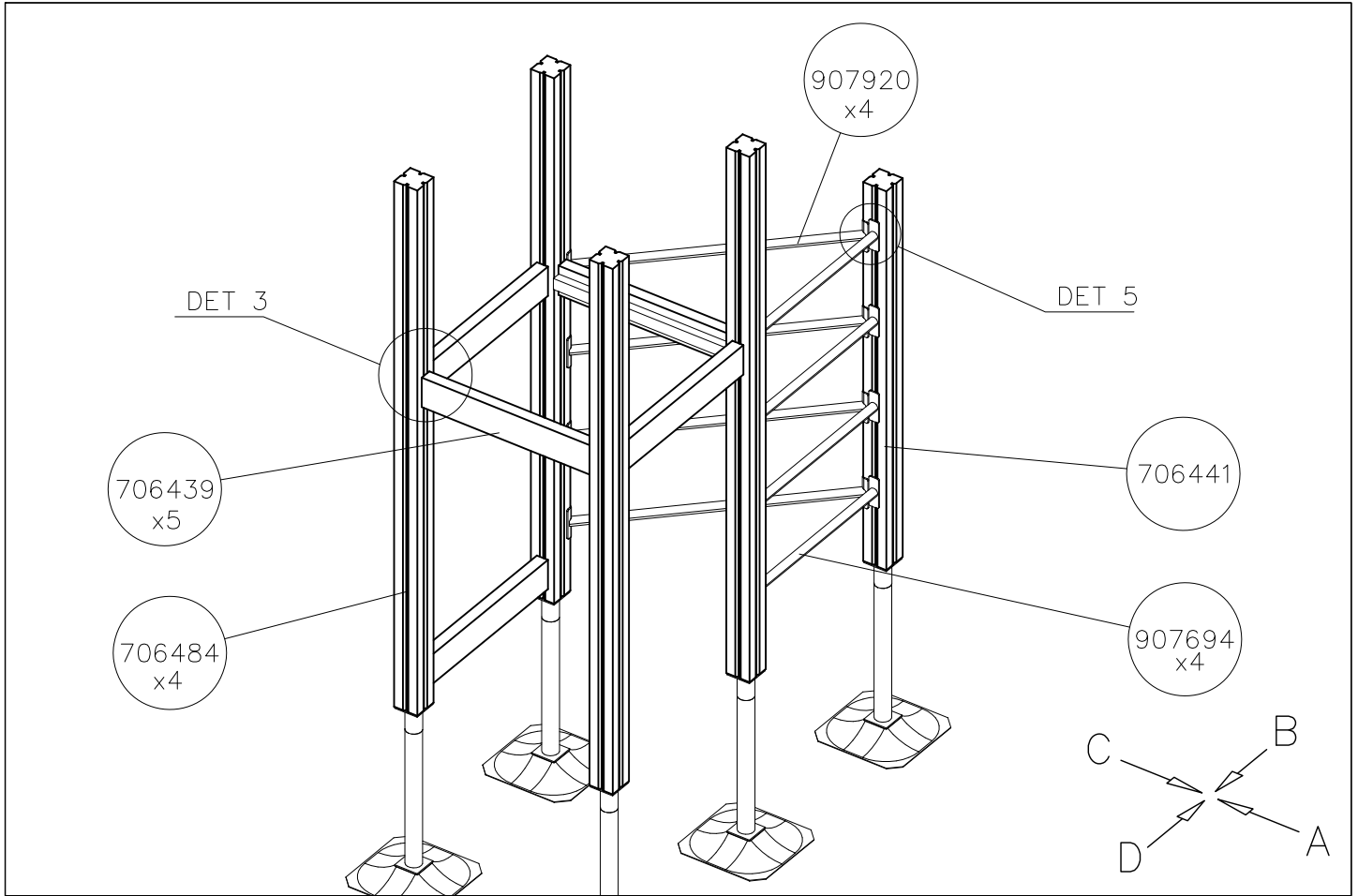

DATE: 31.8.2016

1:50

(A)

(B)

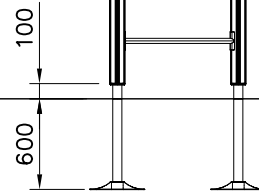
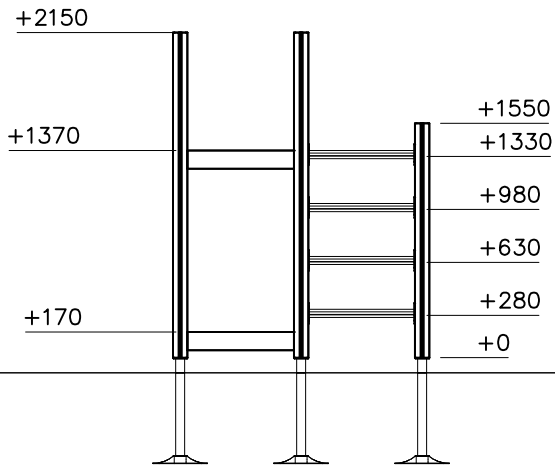

(C)

(D)

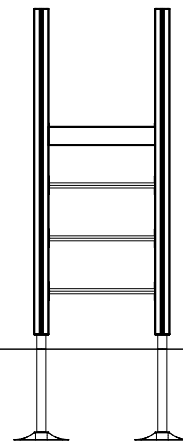
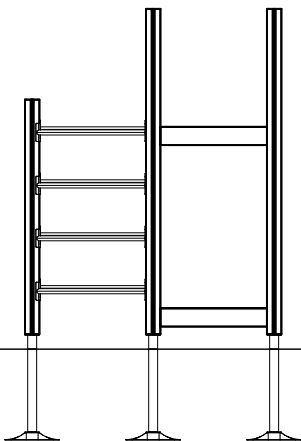

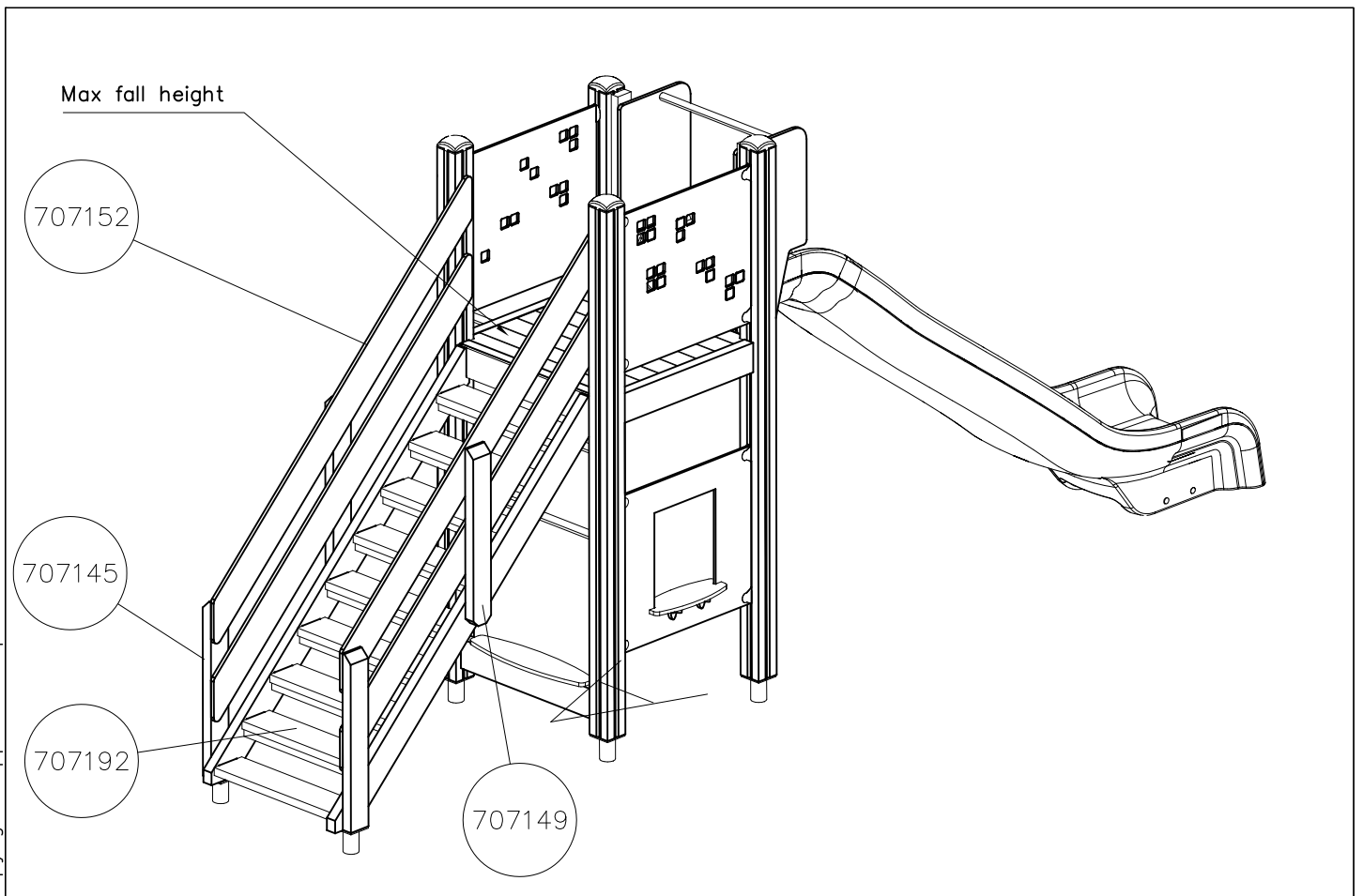
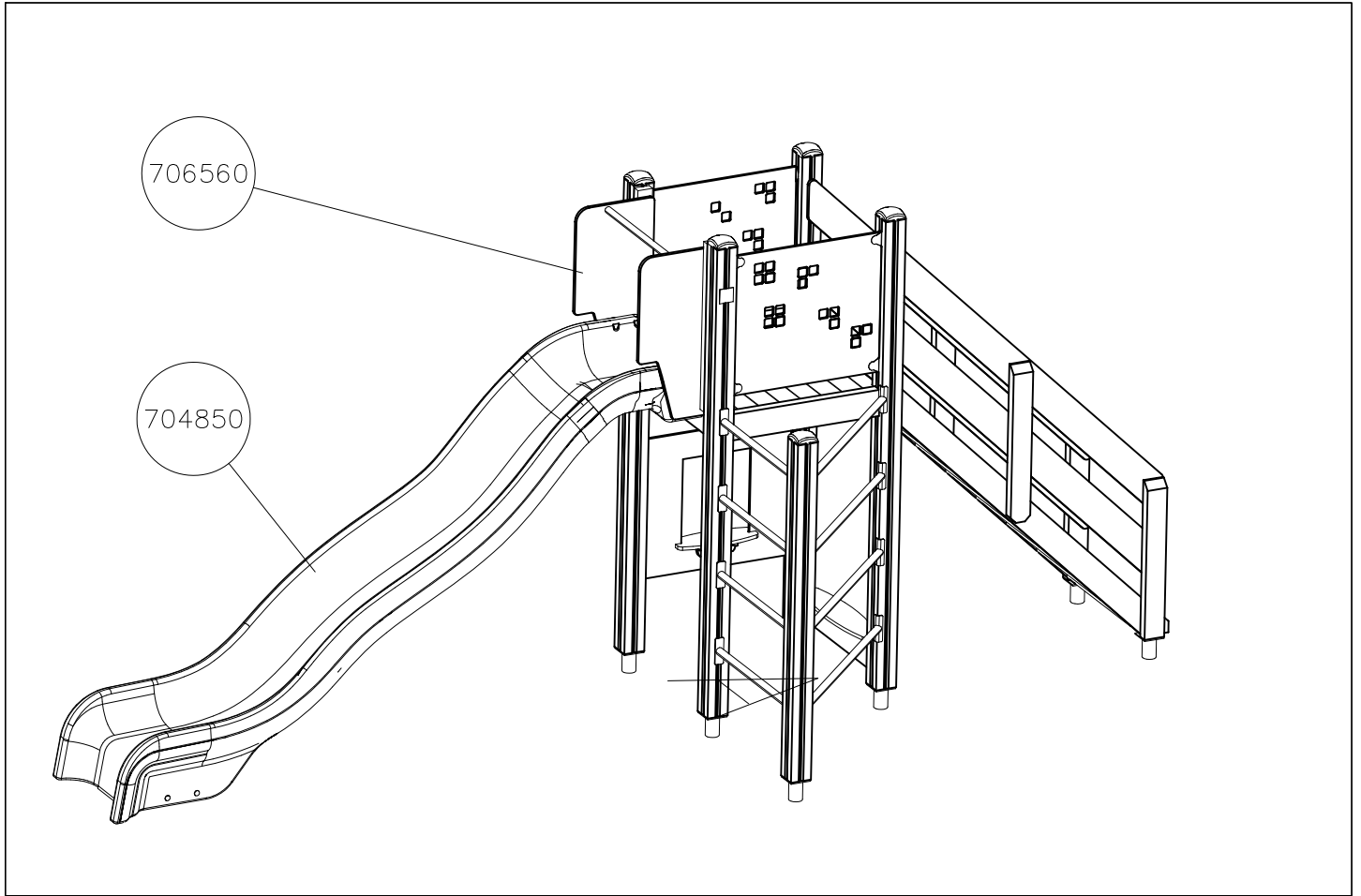

LAPPSET®

FINNO

ASENNUSOHJE
MONTERINGSANSVISNING
INSTALLATION INSTRUCTION
AUFBAUANLEITUNG
NOTICE D'INSTALLATION

DATE: 1.9.2016

137346M

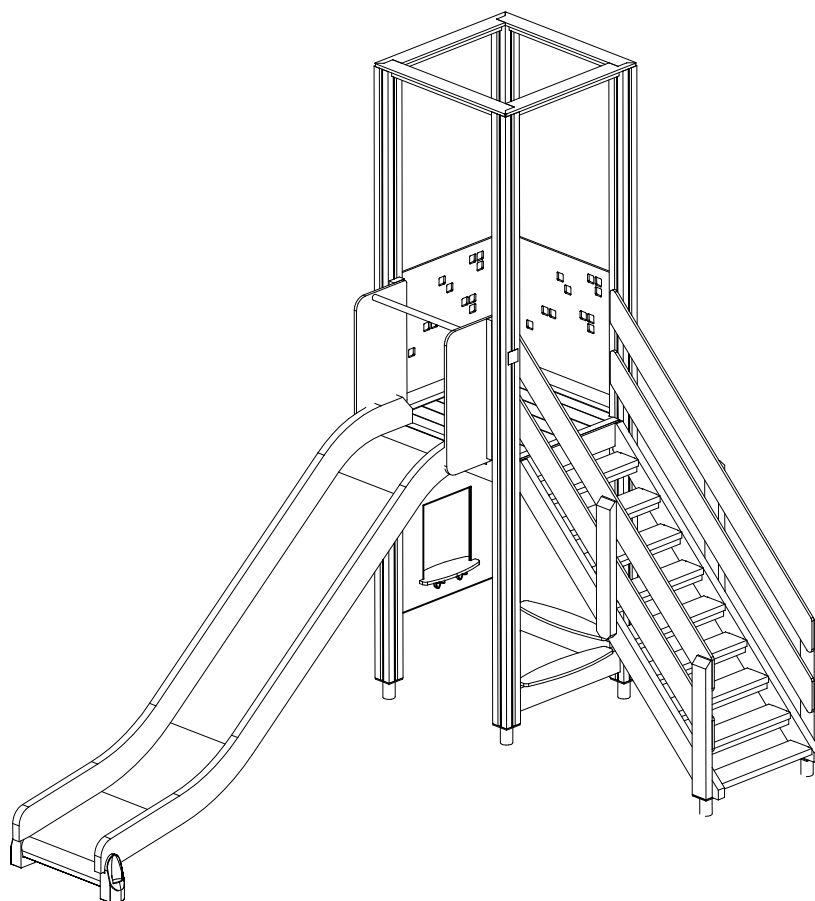

EN/AS Impact Area 24.5 m²
Grid size = 500 mm

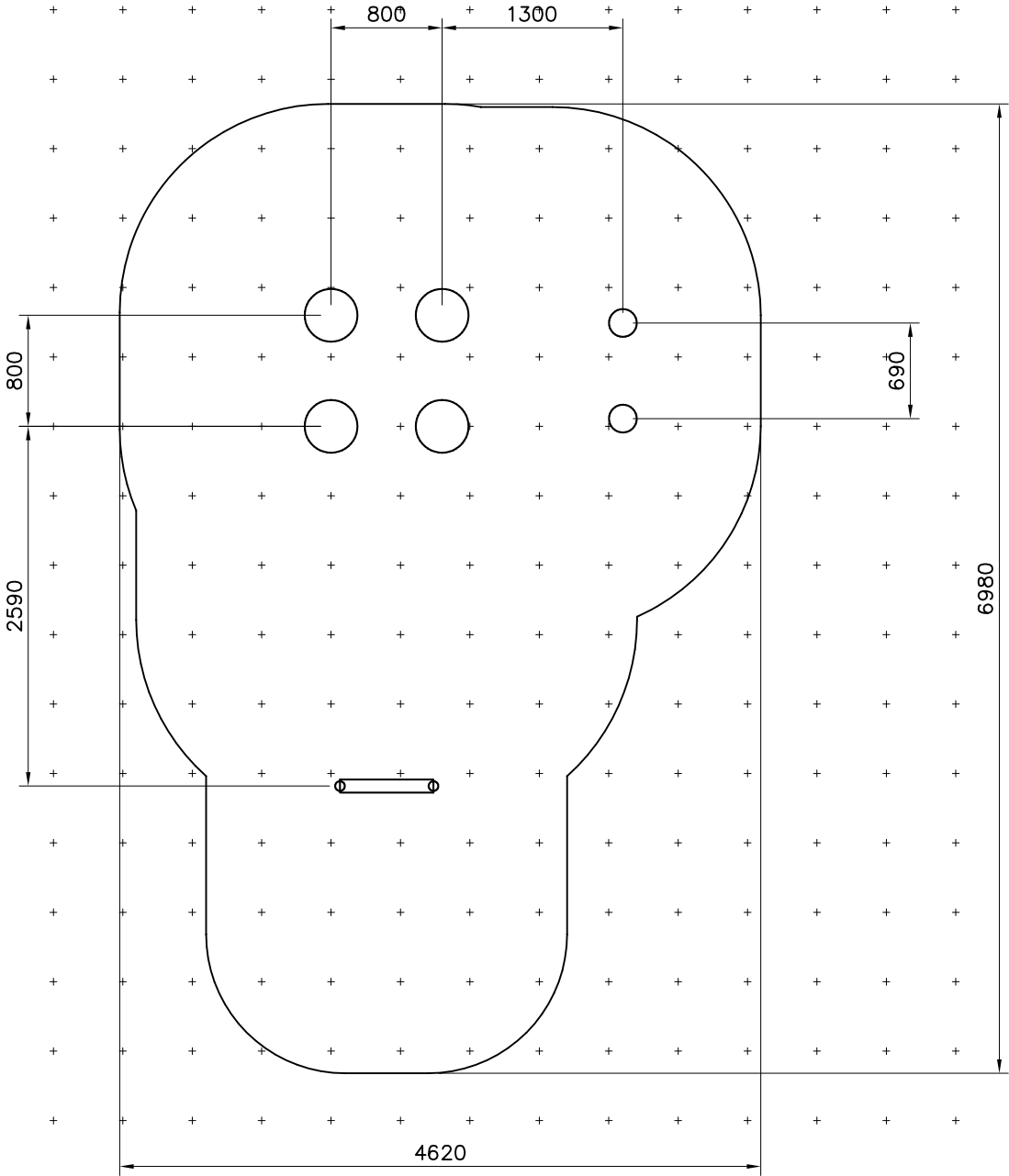
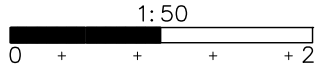

—— EN/AS Impact Area 24.5 m²
- - - - Falling Space 26.7 m²
Max Falling Height 1470 mm

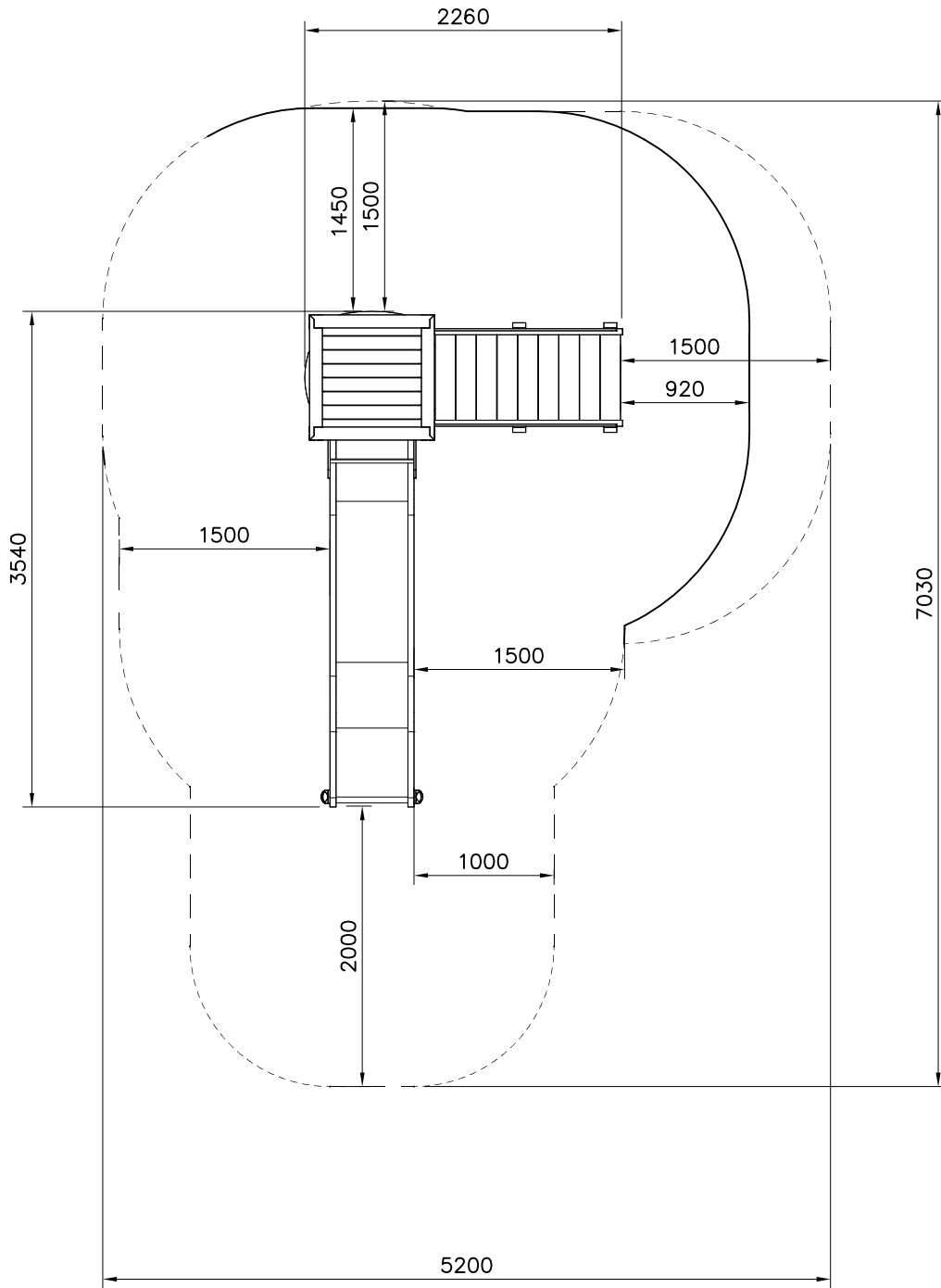
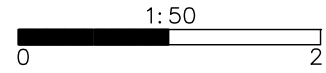

1: 40

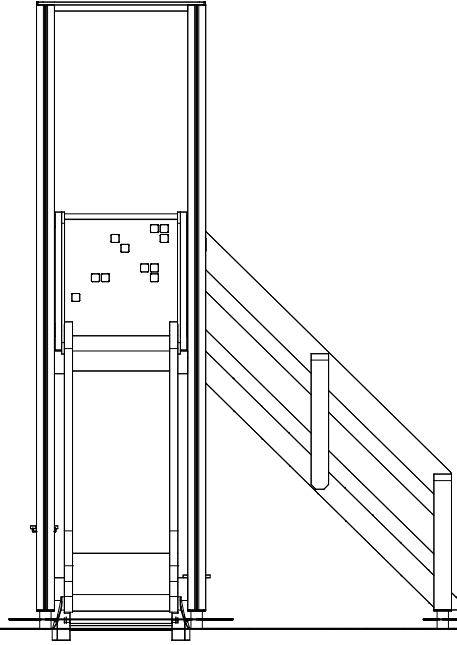

1: 40

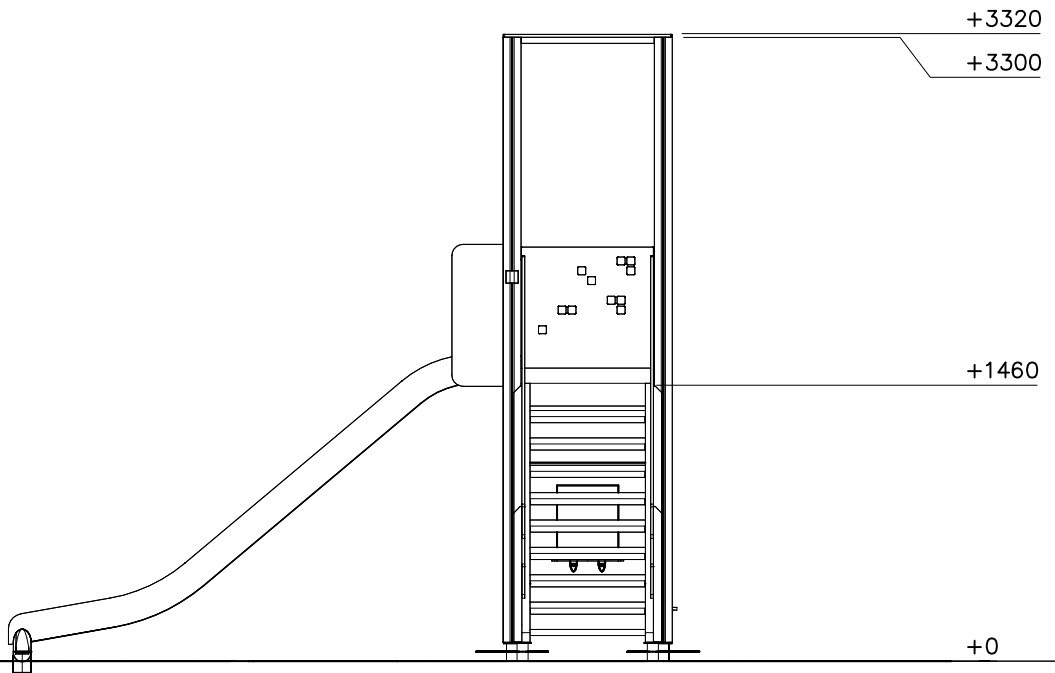

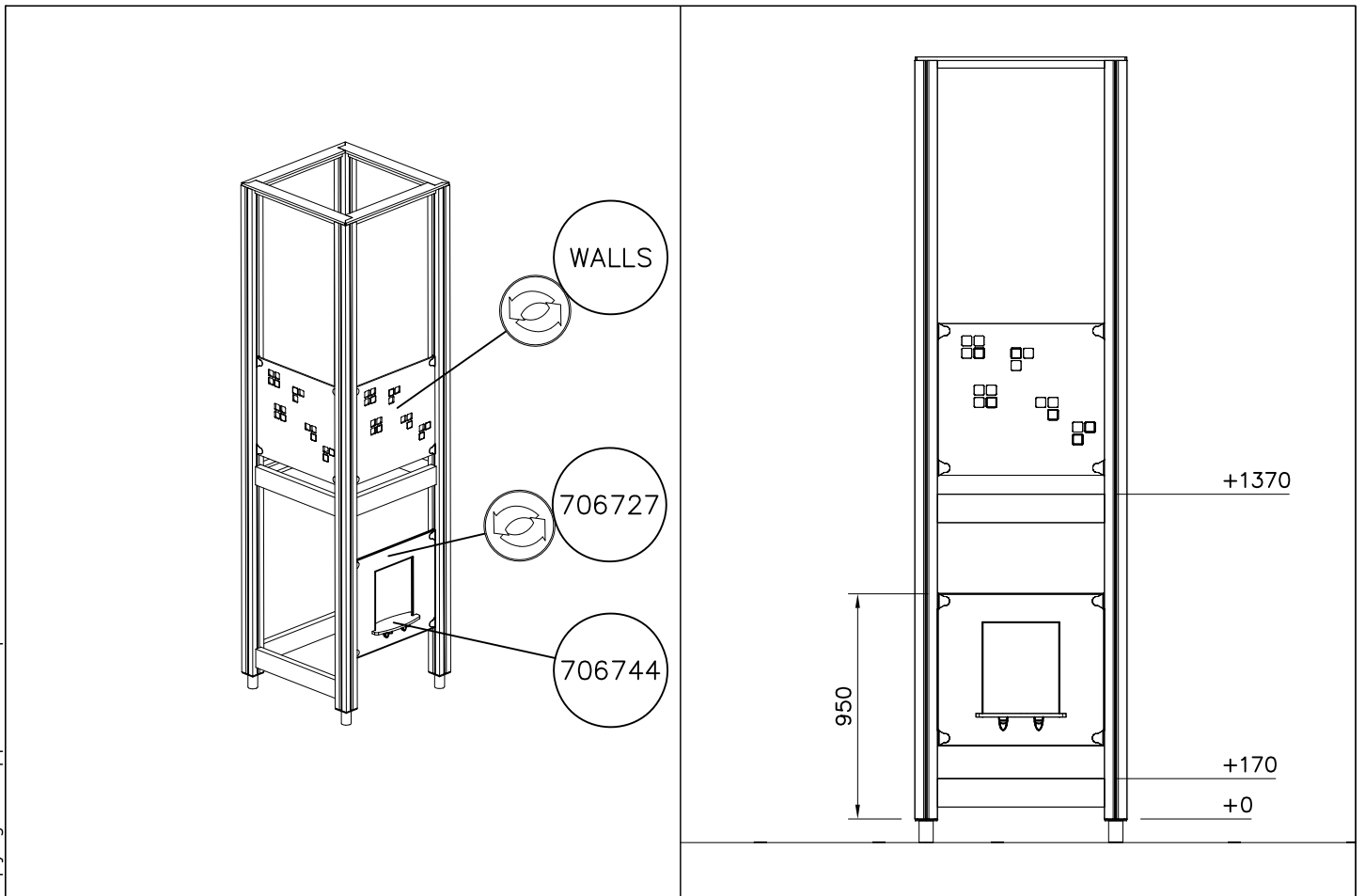
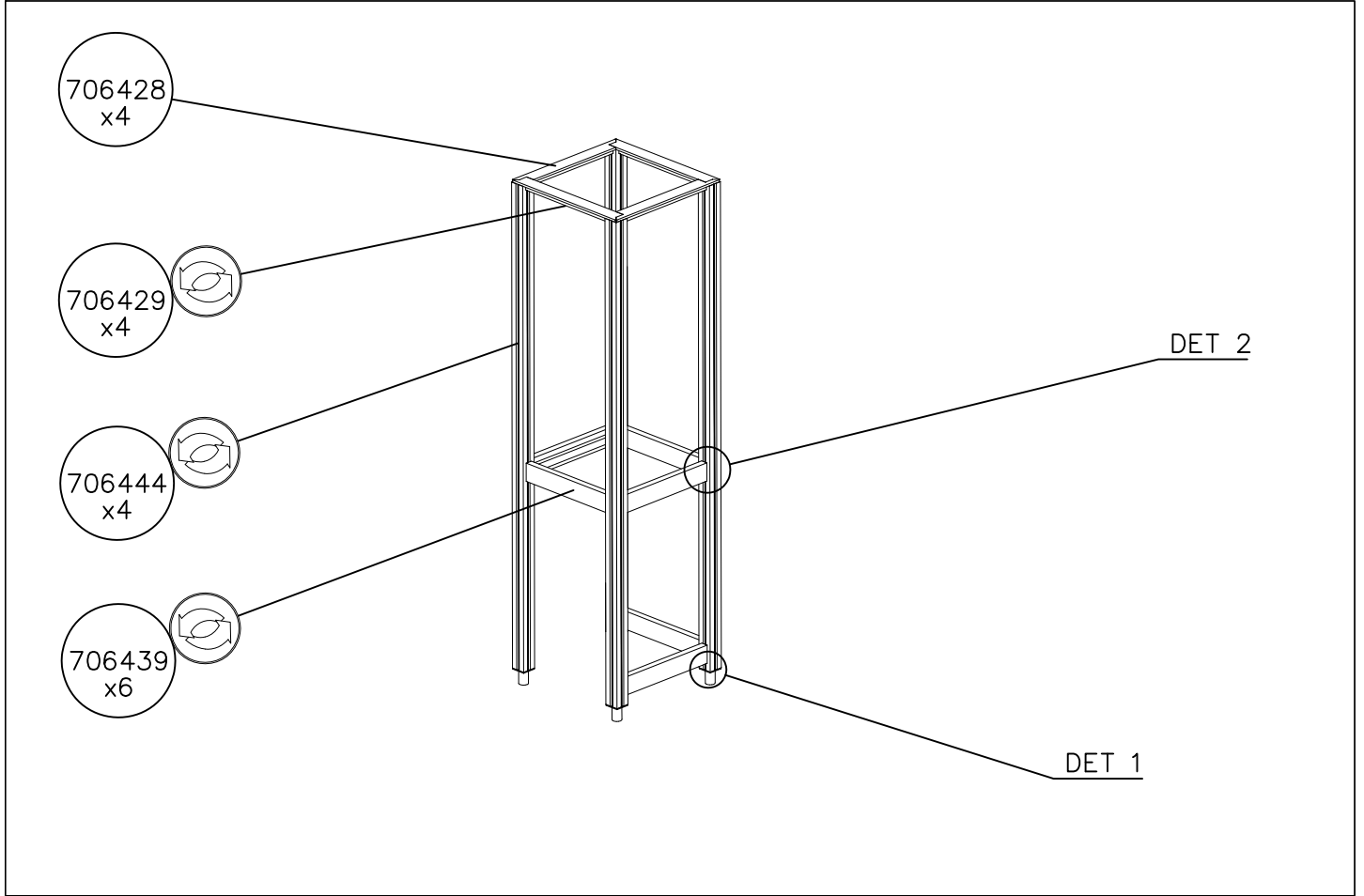

DET 1

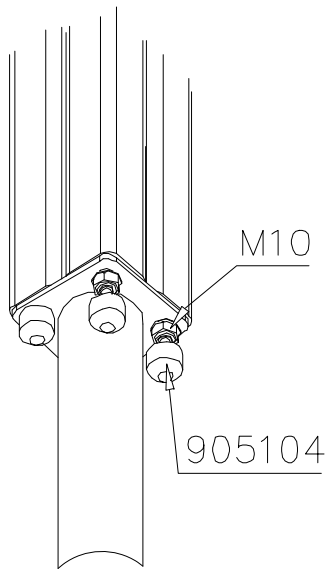

DET 2

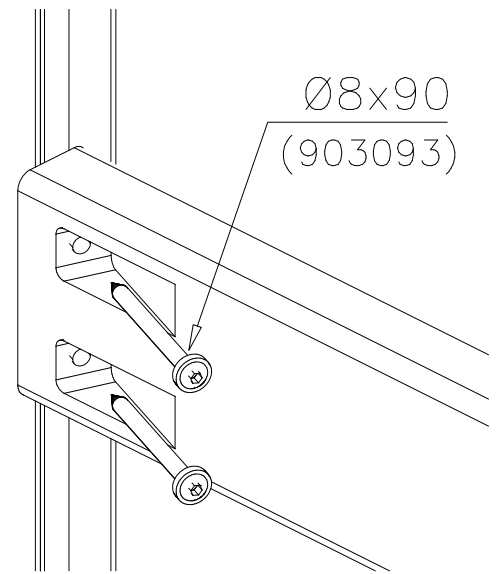

DET 3

DET 4

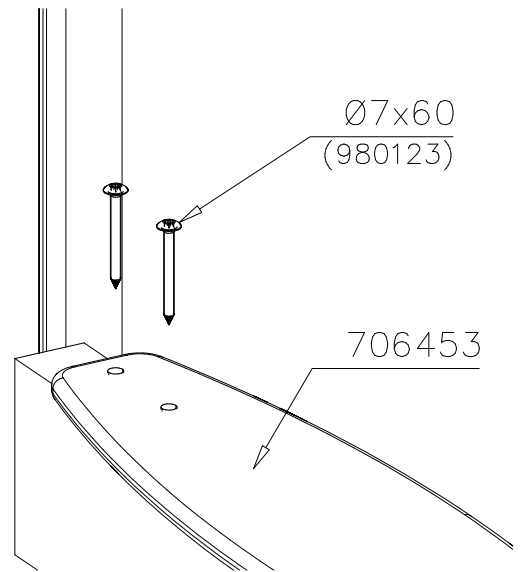

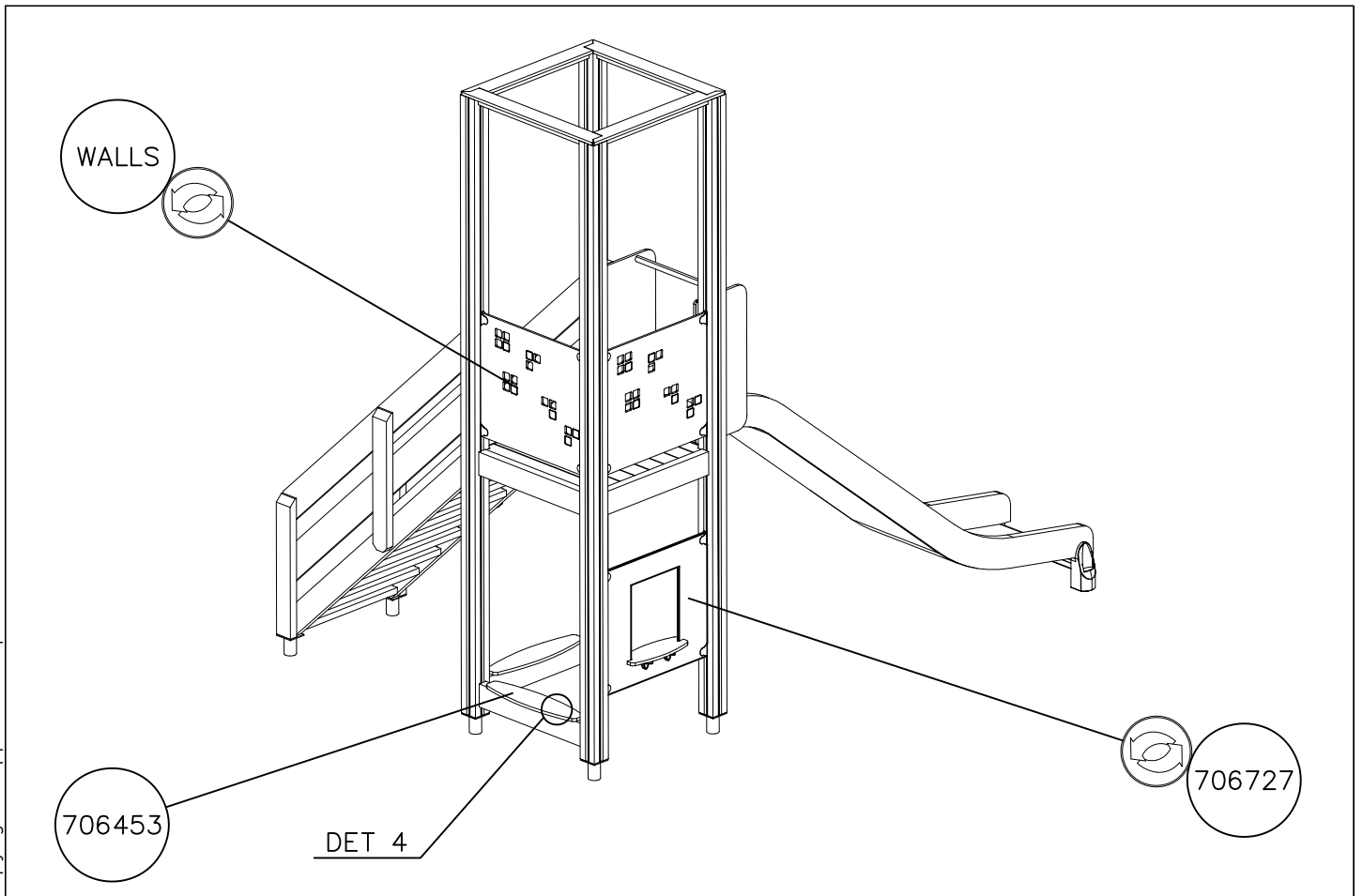
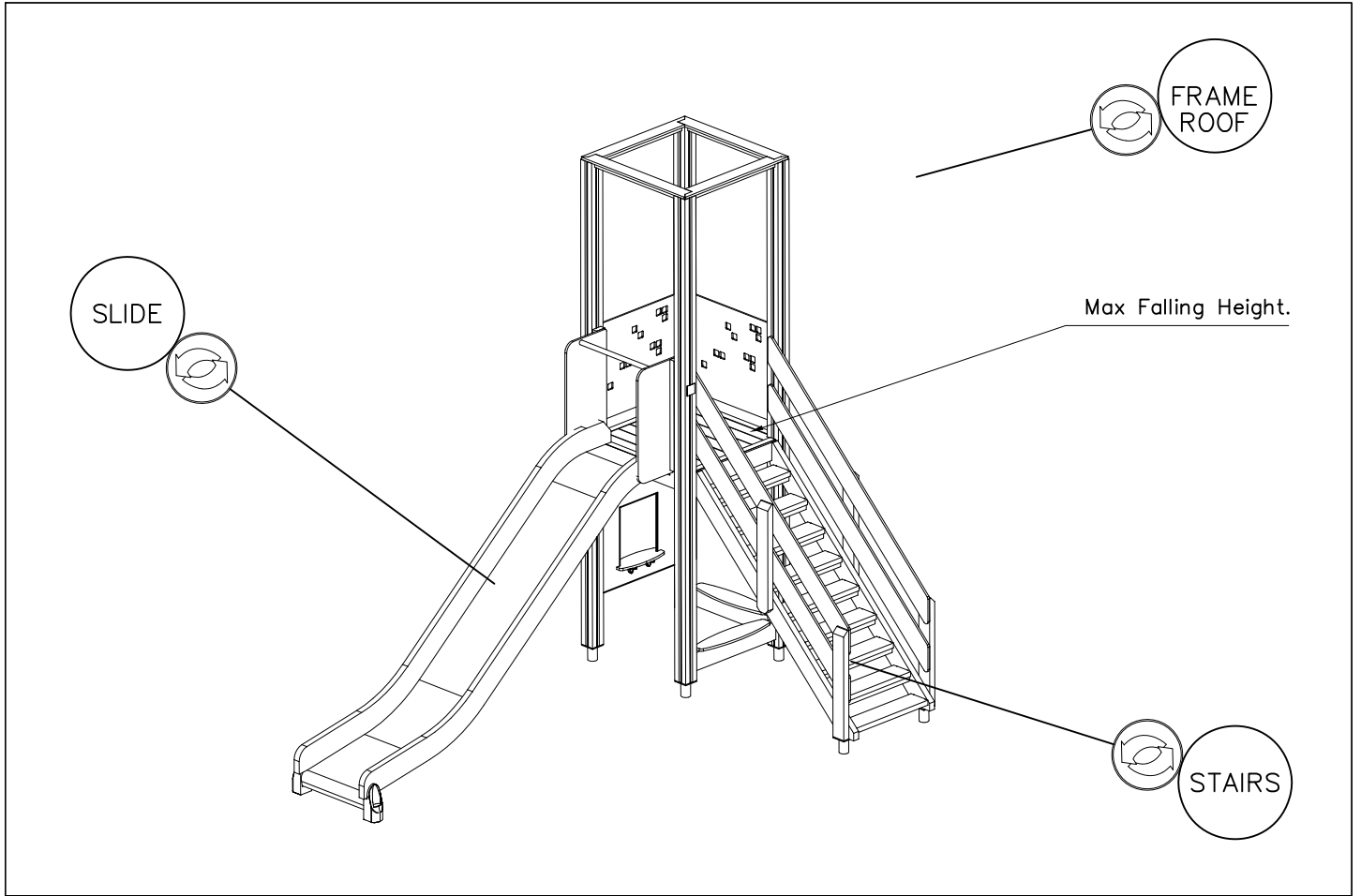

1. Tarkista tuoteosaluettelon ja osiin merkittyjen tuotenumeroiden avulla, että kaikki osat sisältyvät toimitukseen.
2. Valitse välineelle paikka ottaen huomioon valmistajan asennusohjeessa ilmoittamat turvaetäisyydet. Valitessasi välineen asennussuuntaa, huomioi mahdollinen altistuminen voimakkaalle auringonpaisteelle tai tuulelle. Tasoita alue ja tee ohjeen mukaiset perustustyöt. Varmista, että perustusosien alapuolinen maa on **tiivistetty riittävästi**. Tarvittaessa pohjamaa tulee vaihtaa murskeeseen tai vastaavaan kantavaan maainekseen. Iskua vaimentavan pintamateriaalin vahvuus määräytyy laskentakaavan perusteella, joka esitetään perustusohjeen lisäsivulla.
3. Välineen rungon pystystysohje esitetään sivulla 6. Yksityiskohtaiset kuvat asennuksesta on koottu erillisille ohjesivuille, joissa ne on ryhmitelty kiinnitystavan mukaan. Runkoon kiinnitettävistä komponenteista on erilliset moduuliohjeet. Noudata valmistajan asennusohjeessa ilmoittamia mitoituksia.
4. Tarkasta, että väline on suorassa ja perustukseltaan tukeva. Syväperusteisissa välineissä on suoritettava **riittävä maan tiivistäminen** kaivantojen täytön yhteydessä.
5. Tee käyttöönottotarkastus ennen välineen käyttöönottoa toimitukseen sisältyvän pöytäkirjan mukaisesti. Pöytäkirja tulee dokumentoida. Muista, että pääsy välineeseen tulee estää, kunnes se on valmis, turvallinen ja kaikki asennustarvikkeet on viety pois.

1. Kontrollera stycklistan och delarna i förpackningen med hjälp av produktnumren.
2. När du väljer platsen för utrustningen bör du beakta de säkerhetsavstånd som tillverkaren meddelat i monteringsanvisningarna. När du väljer monteringsriktning måste du beakta eventuell exponering för solsken eller vind. Jämna ut underlaget och utför grundarbetet i enlighet med instruktionerna. Säkra att marken under fundamentet är tillräckligt komprimerad. Vid behov kan man ersätta jorden med krossad sten eller motsvarande bärande jordmaterial. Styrkan på det slagdämpande ytmaterialet bestäms med hjälp av beräkningsformeln som presenteras på fundamentinstruktionernas tilläggsida.
3. Monteringsanvisningarna till utrustningens stomme finns på sidan 6. Detaljerade bilder av installationen har samlats på separata instruktionssidor, där de har grupperats enligt monteringsmetod. Det finns specifika modulanvisningar till de komponenter som ska sättas fast i stommen. Följ de dimensioner som tillverkaren gett i monteringsanvisningarna.
4. Kontrollera att utrustningen står rakt och stabilt. För utrustningar med djupt fundament måste man komprimera jorden ordentligt när man fyller igen groparna.
5. Innan utrustningen tas i bruk ska en slutbesiktning i enlighet med protokollet i leveransen utföras. Protokollet måste dokumenteras. Kom ihåg att tillträde till utrustningen måste förhindras tills den är färdig monterad, säker och alla monteringsstillbehör avlägsnats.

1. Use the parts list and the markings on the components to make sure that you have all of the necessary parts.
2. Choose a location for the product, taking into account the safety margins specified in the mounting instructions. When deciding on the orientation of the product, pay attention to potential sun and wind loads. Level the ground and prepare the foundations as instructed. Make sure that the ground underneath the foundations is solidly packed. If necessary, replace soil with wood chips or some other sturdy material. The thickness of the safety surfacing should be calculated using the formula supplied with the mounting instructions.
3. Assemble the frame of the product in accordance with the instructions on page 6. Detailed instructions for the different mounting alternatives are shown in the supplement. Separate instructions are provided for the modular components that will be attached to the frame. Please follow the stated measurements carefully.
4. Make sure that the product is mounted straight and firmly into the ground. Remember to pack the soil carefully when refilling the excavation around deep-mounted structures.
5. Inspect the installation thoroughly using the checklist provided. Document the completed checklist carefully. Remember to stop children from using the product until it has been fully built and safety-tested and all mounting equipment has been cleared away.

1. Überprüfen Sie die Lieferung auf Vollständigkeit, indem Sie das Teileverzeichnis mit der Lieferung abgleichen.
2. Wählen Sie einen Standort für das Gerät und berücksichtigen Sie die vom Hersteller in der Installationsanleitung genannten Sicherheitsabstände. Bei der Ausrichtung des Gerätes beachten Sie den möglichen Einfluss von starker Sonneneinstrahlung oder Wind. Ebenen Sie den Bereich und führen Sie die Fundamentarbeiten nach der Anleitung durch. Stellen Sie sicher, dass der Boden unter den Fundamentteilen ausreichend verdichtet ist. Wenn nötig, muss das Untergrundmaterial durch Split oder ein anderes tragfähiges Material ausgetauscht werden. Die Stärke des stoßdämpfenden Oberflächenmaterials wird auf Grundlage einer Formel berechnet, die im Anhang der Anleitung für die Fundamente dargestellt ist.
3. Die Aufbauanleitung für den Rahmen des Gerätes finden Sie auf Seite 6. Detaillierte Bilder der Installation sind auf gesonderten Anleitungsseiten zusammengestellt, auf denen sie nach ihrer Befestigungsweise geordnet sind. Für die am Geräterahmen befestigten Komponenten gibt es besondere Modulanleitungen. Halten Sie die in der Installationsanleitung vom Hersteller genannten Maße ein.
4. Überprüfen Sie, dass das Gerät in Waage steht und sicher am Boden verankert ist. Bei Geräten mit Tiefenfundamenten muss der Boden beim Auffüllen des Aushubs ausreichend verdichtet oder betoniert werden.
5. Führen Sie eine Inbetriebnahmeüberprüfung entsprechend des im Lieferumfang enthaltenen Protokolls durch, bevor das Gerät benutzt wird. Das Protokoll muss aktenkundig dokumentiert werden. Denken Sie daran, dass der Zugang zum Gerät verhindert werden muss, bis es fertig und sicher ist und alle Installationswerkzeuge entfernt sind.

1. Vérifier à l'aide de la liste des pièces et des numéros de produit marqués sur les pièces que la livraison comprend toutes les pièces nécessaires.
2. Choisir un bon emplacement pour l'équipement, compte tenu des distances de sécurité indiquées par le fabricant dans les instructions de montage. Tenir compte de l'exposition éventuelle aux forts rayons de soleil ou au vent lors du choix du sens de montage de l'équipement. Egaliser la surface de l'emplacement choisi et effectuer les travaux de fondation conformément aux instructions. S'assurer que le sol sous les pièces de fondation a été suffisamment compacté. Si besoin est, le sol de fondation doit être remplacé par des pierres concassées ou un matériau portant similaire. L'épaisseur du matériau de surface anti-choc est calculée selon la formule indiquée à la page supplémentaire des instructions de fondation.
3. Les instructions d'érection de l'ossature de l'équipement sont indiquées à la page 6. Les images détaillées du montage sont adjointes aux pages d'instruction séparées où elles sont groupées selon le mode de fixation. Des instructions modulaires séparées sont données pour les composants à fixer sur l'ossature. Respecter les mesures données par le fabricant dans les instructions de montage.
4. Vérifier que l'équipement est droit et que sa fondation est solide. Dans le cas des équipements dont la fondation se trouve sous le sol, le sol doit être suffisamment compacté lors du remplissage des trous.
5. Effectuer un contrôle de mise en service conforme au procès-verbal compris dans la livraison avant la mise en service de l'équipement. Ce procès-verbal doit être documenté. Ne pas oublier d'empêcher l'accès à l'équipement jusqu'à ce que celui-ci soit prêt et sûr et que tous les outils de montage aient été enlevés.

												
<p>$h < 600$</p> <p>Without movement and therefore without Impact Area</p>	<p>Totally hard surfaces.</p> <p>Note. Lappset does <u>not recommend</u> totally hard surfaces at all.</p>	<p>E.g. concrete or asphalt</p> 										
<p>$h < 600$</p> <p>With movement e.g. rocking</p>	<p>Materials with very limited impact attenuating properties.</p>	<p>E.g. wood</p> 										
<p>$h < 1000$</p>	<p>Materials with significant impact attenuating properties.</p>	<p>fine gravel 0–8 mm</p>  <p>grass</p>  <p>unsorted sand</p> 										
<p>$h < 3000$</p>	<p>Loose fill material</p> <p>E.g. sand/gravel 0,25...8 mm D60/D10<3,0 Woodchips 5...30 mm bark 20...80 mm</p>	 <table data-bbox="1021 1691 1332 1792"> <tr> <td>\underline{S}</td> <td>\underline{h}</td> </tr> <tr> <td>30 cm</td> <td>< 2,0 m</td> </tr> <tr> <td>40 cm</td> <td>< 3,0 m</td> </tr> </table>	\underline{S}	\underline{h}	30 cm	< 2,0 m	40 cm	< 3,0 m				
\underline{S}	\underline{h}											
30 cm	< 2,0 m											
40 cm	< 3,0 m											
	<p>Syntethic granulates</p> <table data-bbox="406 1892 758 2060"> <tr> <td>\underline{S}</td> <td>\underline{h}</td> </tr> <tr> <td>40 mm</td> <td>~> 1,2...1,3 m</td> </tr> <tr> <td>50 mm</td> <td>~> 1,5...1,7 m</td> </tr> <tr> <td>60 mm</td> <td>~> 1,8...2,0 m</td> </tr> <tr> <td>70 mm</td> <td>~> 2,1...2,5 m</td> </tr> </table> <p>Note. For accurate values, see manufacturer's instructions.</p>	\underline{S}	\underline{h}	40 mm	~> 1,2...1,3 m	50 mm	~> 1,5...1,7 m	60 mm	~> 1,8...2,0 m	70 mm	~> 2,1...2,5 m	
\underline{S}	\underline{h}											
40 mm	~> 1,2...1,3 m											
50 mm	~> 1,5...1,7 m											
60 mm	~> 1,8...2,0 m											
70 mm	~> 2,1...2,5 m											

REMOVE SAFETY SURFACE/SAND/GRAVEL
TO CHECK FOUNDATION

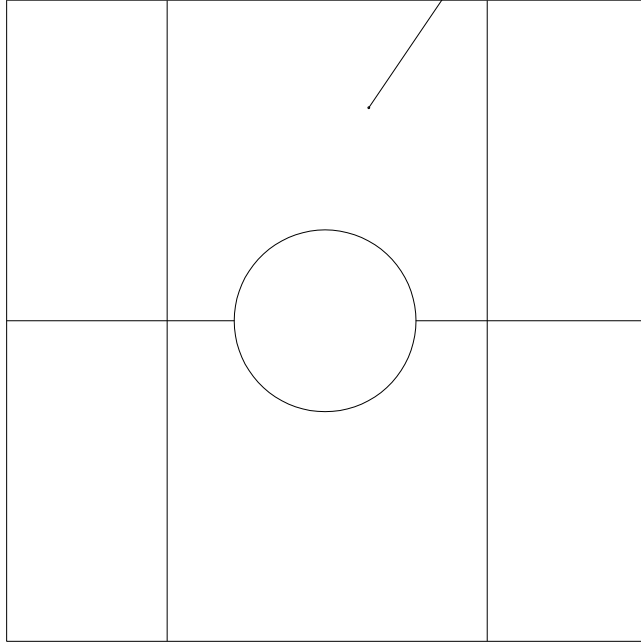

REMOVE SAFETY SURFACE/SAND/GRAVEL
TO CHECK FOUNDATION



LAPPSET®
DEEP FOUNDATION

FOOT

DATE: 13.3.2014

4A



LAPPSET®
BETON FOUNDATION

FOOT

DATE: 27.10.2015

1(1)

② 905104	PCS		PCS
	4		
 M10	PCS		PCS



905104

LAPPSET® DEEP FOUNDATION

FOOT

DATE: 15.5.2018

1(1)



①	909511	PCS	②	909519	PCS
		1			1
	90x90x650			50x380x380	

③	909637	PCS	④	909638	PCS
		4			8
	M10			Ø20/10.5	

⑤	909639	PCS	⑥	905104	PCS
		4			4
	M10x25			M10	

OPTION FOOT

①	911155	PCS			PCS
		1			
	90x90x650				

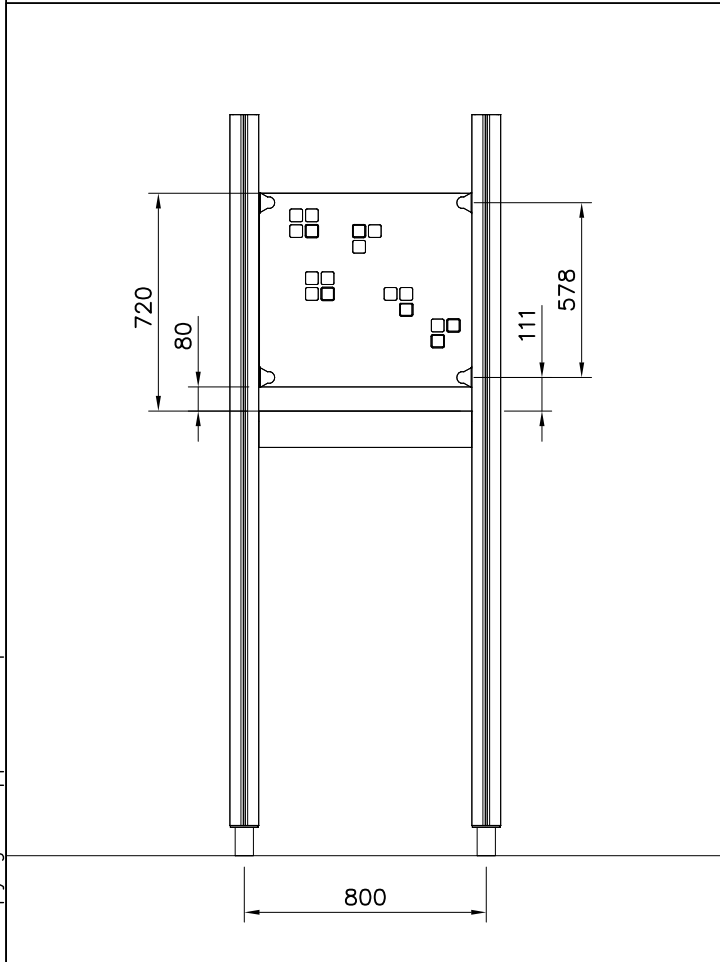
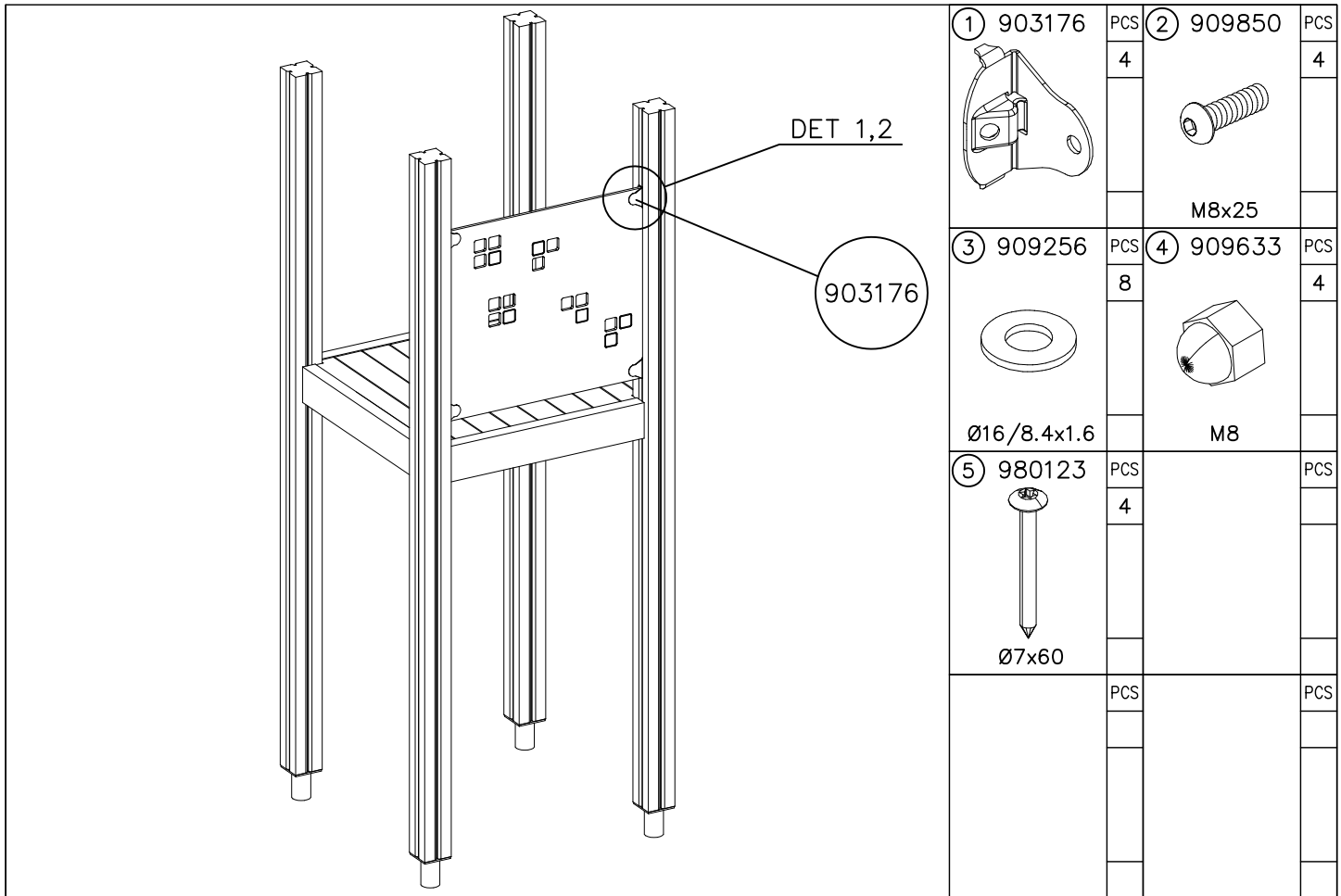

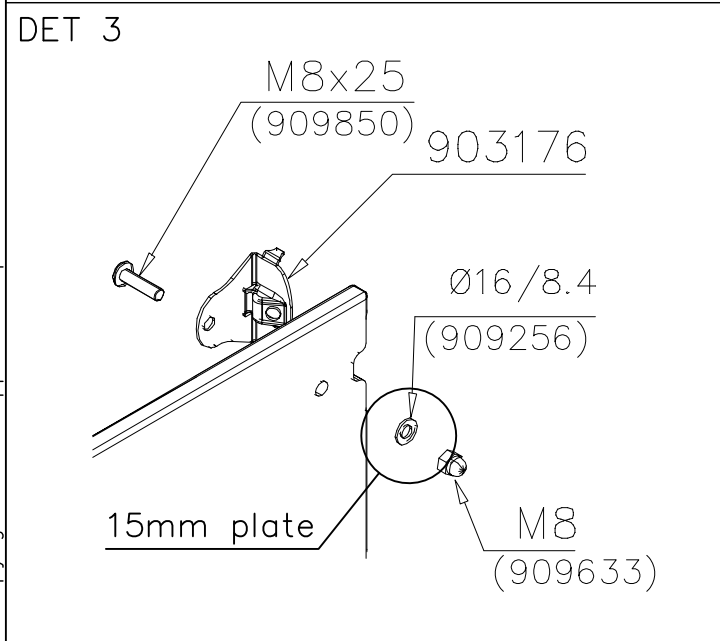
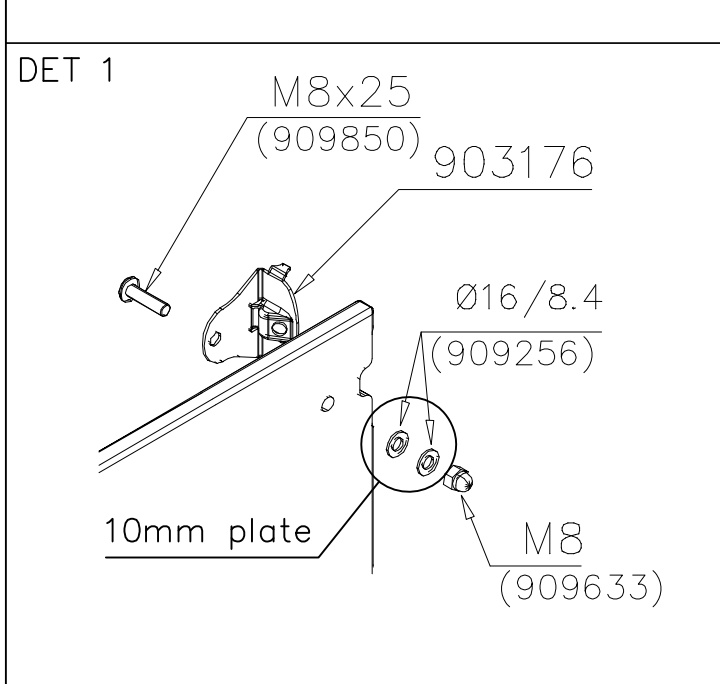
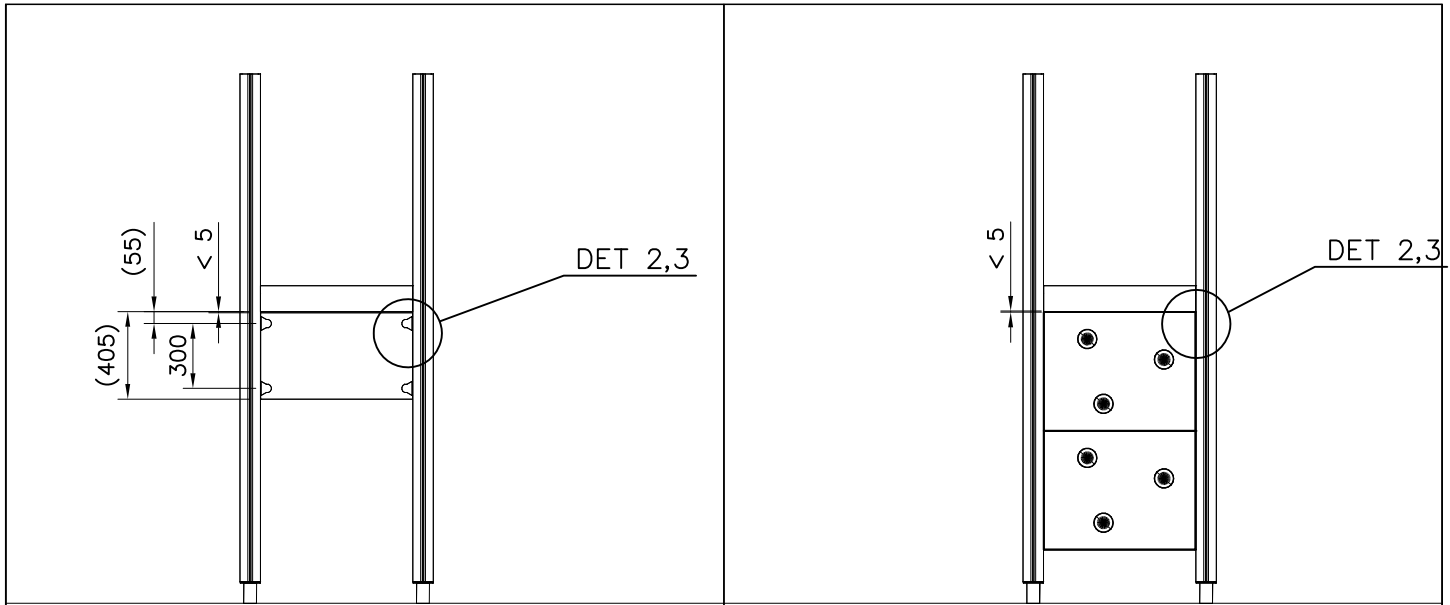

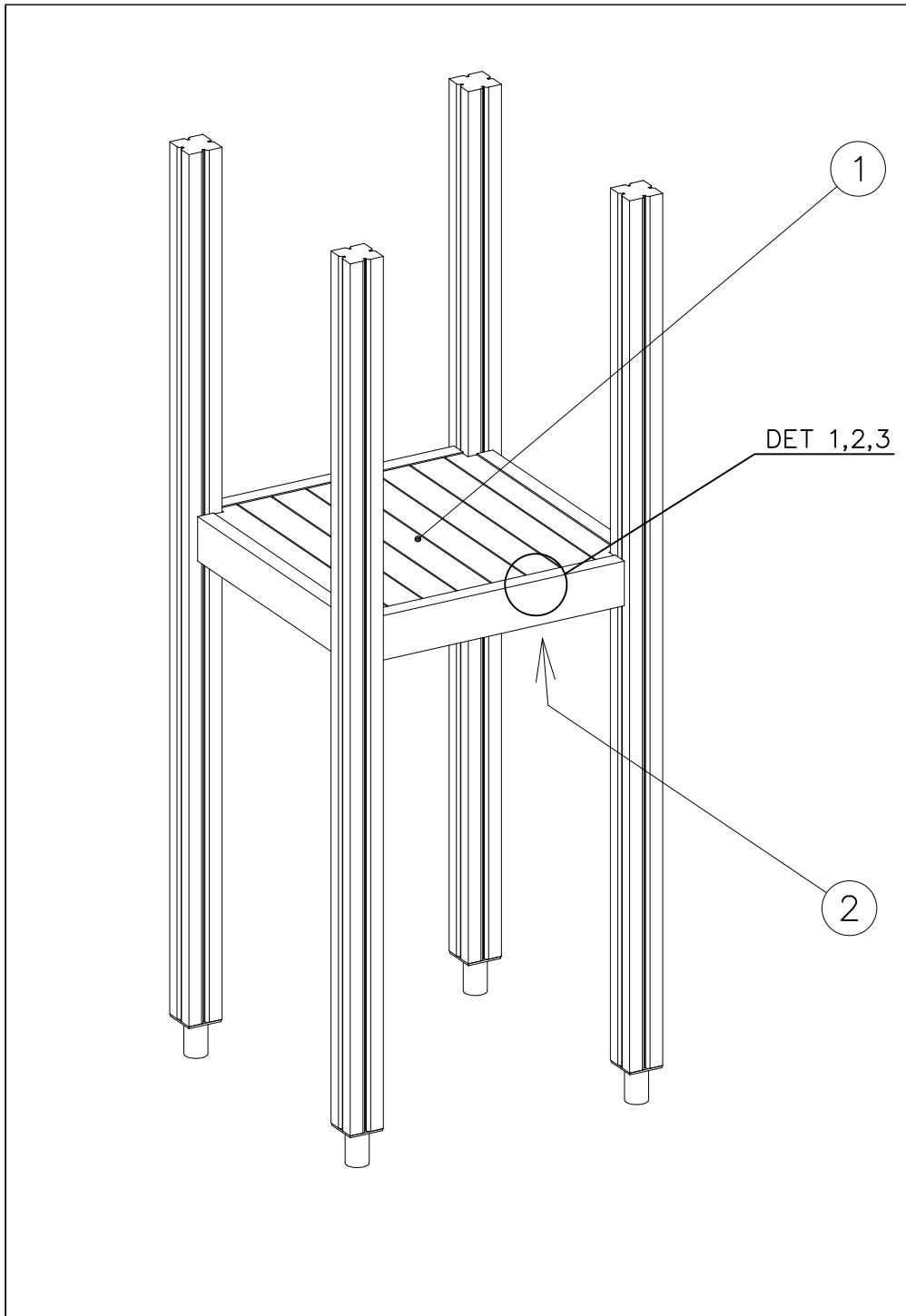

① 008986	PCS	② 706443	PCS
	1		2
750x750		32x45x702	
③ 900240	PCS	④ 980101	PCS
	6		8
Ø8x70		Ø4.5x70	
	PCS		PCS
	PCS		PCS
	PCS		PCS

DET 1



DET 2

Naulanauha kannatinlistan puolelle.
Nail list to the bottom.



DET 3

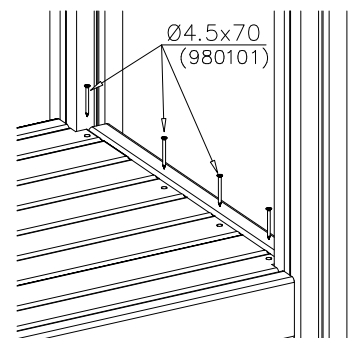

1. The product is available in a choice of colours, components and mounting alternatives.

Please specify your preferences when placing your order. Choose from the following:

Posts and beams: available in three different colours

Walls: available in slatted wood or solid HPL panels in different colours

Roofs: choose between a ridge roof and a hip roof

Foundations: choose between underground anchoring and surface mounting

The roofs, walls and mounting components pictured in the mounting instructions may differ from your order. Alternative components are marked with the **SwitchIt** symbol.



2. Use the parts list and the markings on the components to make sure that you have all of the necessary parts.
3. Choose a location for the product, taking into account the safety margins specified in the mounting instructions. When deciding on the orientation of the product, pay attention to potential sun and wind loads. Level the ground and prepare the foundations as instructed. Make sure that the ground underneath the foundations is solidly packed. If necessary, replace soil with wood chips or some other sturdy material. The thickness of the safety surfacing should be calculated using the formula supplied with the mounting instructions.
4. Assemble the frame of the product in accordance with the instructions on page 6. Detailed instructions for the different mounting alternatives are shown in the supplement. Separate instructions are provided for the modular components that will be attached to the frame. Please follow the stated measurements carefully.
5. Make sure that the product is mounted straight and firmly into the ground. Remember to pack the soil carefully when refilling the excavation around deep-mounted structures.
6. Inspect the installation thoroughly using the checklist provided. Document the completed checklist carefully. Remember to stop children from using the product until it has been fully built and safety-tested and all mounting equipment has been cleared away.

1. Asennettava väline sisältää vaihtoehtoja värien, komponenttien ja perustustavan suhteen.

Vaihtoehdot valitaan tilauksen yhteydessä. Näihin kuuluvat seuraavat osat:

Tolpat ja puomit: Kolme eri väri vaihtoehtoa
Seinät: Vaihtoehtoina eriväriset puusäle- ja levyseinät
Katot: Vaihtoehtoina harja- tai aumakatto
Perustukset: Vaihtoehtoina syvä- ja pintaperustus

Asennusohjeen kuvissa voivat katot, seinät ja perustusosat poiketa toimituksen sisällöstä. Ohjeessa nämä vaihtoehtoiset osat on merkitty **Switch It**-merkillä.



2. Tarkasta tuoteosaluettelon ja osiin merkittyjen tuotenumeroitten avulla, että kaikki osat sisältyvät toimitukseen.
3. Valitse välineelle paikka ottaen huomioon valmistajan asennusohjeessa ilmoittamat turvaetäisyydet. Valitessasi välineen asennussuuntaa, huomioi mahdollinen altistuminen voimakkaalle auringonpaisteelle tai tuulelle. Tasoita alue ja tee ohjeen mukaiset perustustyöt. Varmista, että perustusosien alapuolinen maa on **tiivistetty riittävästi**. Tarvittaessa pohjamaa tulee vaihtaa murskeeseen tai vastaavaan kantavaan maa-ainekseen. Iskua vaimentavan pintamateriaalin vahvuus määräytyy laskentakaavan perusteella, joka esitetään perustusohjeen lisäsivulla.
4. Välineen rungon pystytysohje esitetään sivulla 6. Yksityiskohtaiset kuvat asennuksesta on koottu erillisille ohjesivuille, joissa ne on ryhmitelty kiinnitystavan mukaan. Runkoon kiinnitettävistä komponenteista on erilliset moduuliohjeet. Noudata valmistajan asennusohjeessa ilmoittamia mitoituksia.
5. Tarkasta, että väline on suorassa ja perustukseltaan tukeva. Syväperusteisissa välineissä on suoritettava **riittävä maan tiivistäminen** kaivantojen täytön yhteydessä.
6. Tee käyttöönottotarkastus ennen välineen käyttöönottoa toimitukseen sisältyvän pöytäkirjan mukaisesti. Pöytäkirja tulee dokumentoida. Muista, että pääsy välineeseen tulee estää, kunnes se on valmis, turvallinen ja kaikki asennustarvikkeet on viety pois.

1. Man kan välja mellan olika färger, komponenter och fundament på lekplatsutrustningen.

Alternativen specificeras i samband med beställningen. Till dessa hör följande delar:

Stolpar och bommar: tre olika färger

Väggar: väggar i olika färger av träpaneler eller hpl-skivor

Tak: sadel- eller dubbelbrutet tak

Grundkonstruktion: djup- eller ytfundament

På bilderna i monteringsanvisningarna kan tak, väggar och fundament skilja sig från leveransens innehåll. I instruktionerna har dessa alternativa delar märkts med märket **Switch It**



2. Kontrollera stycklistan och delarna i förpackningen med hjälp av produktnumren.
3. När du väljer platsen för utrustningen bör du beakta de säkerhetsavstånd som tillverkaren meddelat i monteringsanvisningarna. När du väljer monteringsriktning måste du beakta eventuell exponering för solsken eller vind. Jämna ut underlaget och utför grundarbetet i enlighet med instruktionerna. Säkra att marken under fundamentet är tillräckligt komprimerad. Vid behov kan man ersätta jorden med krossad sten eller motsvarande bärande jordmaterial. Styrkan på det slagdämpande ytmaterialet bestäms med hjälp av beräkningsformeln som presenteras på fundamentinstruktionernas tilläggsida.
4. Monteringsanvisningarna till utrustningens stomme finns på sidan 6. Detaljerade bilder av installationen har samlats på separata instruktionssidor, där de har grupperats enligt monteringsmetod. Det finns specifika modulanvisningar till de komponenter som ska sättas fast i stommen. Följ de dimensioner som tillverkaren gett i monteringsanvisningarna.
5. Kontrollera att utrustningen står rakt och stabilt. För utrustningar med djupt fundament måste man komprimera jorden ordentligt när man fyller igen groparna.
6. Innan utrustningen tas i bruk ska en slutbesiktning i enlighet med protokollet i leveransen utföras. Protokollet måste dokumenteras. Kom ihåg att tillträde till utrustningen måste förhindras tills den är färdig monterad, säker och alla monteringsstillbehör avlägsnats.

1. Das zu installierende Gerät enthält Alternativen in Bezug auf Farben, Komponenten und Fundament.

Die Alternativen werden bei der Bestellung ausgewählt. Hierzu zählen:

Pfosten und Balken: drei verschiedene Farbvarianten stehen zur Auswahl

Wände: verschiedenfarbige Holzlamellen- und HPL-Wandelemente stehen zur Auswahl

Dächer: Auswahl zwischen Pyramidendach oder Satteldach

Fundamente: Auswahl zwischen Tiefen- oder Oberflächenmontage

Die in der Installationsanleitung dargestellten Dächer, Wände und Fundamentteile können vom Inhalt der Lieferung abweichen. In der Anleitung werden diese Teile mit dem SwitchI- Zeichen gekennzeichnet.



2. Überprüfen Sie die Lieferung auf Vollständigkeit, indem Sie das Teileverzeichnis mit der Lieferung abgleichen.
3. Wählen Sie einen Standort für das Gerät und berücksichtigen Sie die vom Hersteller in der Installationsanleitung genannten Sicherheitsabstände. Bei der Ausrichtung des Gerätes beachten Sie den möglichen Einfluss von starker Sonneneinstrahlung oder Wind. Ebenen Sie den Bereich und führen Sie die Fundamentarbeiten nach Anleitung durch. Stellen Sie sicher, dass der Boden unter den Fundamentteilen ausreichend verdichtet ist. Wenn nötig, muss das Untergrundmaterial durch Split oder ein anderes tragfähiges Material ausgetauscht werden. Die Stärke des stoßdämpfenden Oberflächenmaterials wird auf Grundlage einer Formel berechnet, die im Anhang der Anleitung für die Fundamente dargestellt ist.
4. Die Aufbauanleitung für den Rahmen des Gerätes finden Sie auf Seite 6. Detaillierte Bilder der Installation sind auf gesonderten Anleitungsseiten zusammengestellt, auf denen sie nach ihrer Befestigungsweise geordnet sind. Für die am Geräterahmen befestigten Komponenten gibt es besondere Modulanleitungen. Halten Sie die in der Installationsanleitung vom Hersteller genannten Maße ein.
5. Überprüfen Sie, dass das Gerät in Waage steht und sicher am Boden verankert ist. Bei Geräten mit Tiefenfundamenten muss der Boden beim Auffüllen des Aushubs ausreichend verdichtet oder betoniert werden.
6. Führen Sie eine Inbetriebnahmeüberprüfung entsprechend des im Lieferumfang enthaltenen Protokolls durch, bevor das Gerät benutzt wird. Das Protokoll muss aktenkundig dokumentiert werden. Denken Sie daran, dass der Zugang zum Gerät verhindert werden muss, bis es fertig und sicher ist und alle Installationswerkzeuge entfernt sind.

1. L'équipement à monter comporte des choix de couleurs, de composants et de modes de fondation.

Les options sont choisies lors de la commande. Elles comprennent les composants suivants :

Poteaux et poutres : Trois couleurs optionnelles

Parois : Parois en lattes de bois et en plaques de diverses couleurs

Toits : Choix entre un toit à deux pentes ou un toit en croupe

Fondations : Choix entre une fondation sous le sol et en surface

Sur les images des instructions de montage, les toits, les parois et les pièces de la fondation peuvent être différents de ceux de la commande. Ces pièces optionnelles sont indiquées, dans les instructions, par la marque SwitchIt.



2. Vérifier à l'aide de la liste des pièces et des numéros de produit marqués sur les pièces que la livraison comprend toutes les pièces nécessaires.
3. Choisir le bon emplacement pour l'équipement, compte tenu des distances de sécurité indiquées par le fabricant dans les instructions de montage. Tenir compte de l'exposition éventuelle aux forts rayons de soleil ou au vent lors du choix du sens de montage de l'équipement. Egaliser la surface de l'emplacement choisi et effectuer les travaux de fondation conformément aux instructions. S'assurer que le sol sous les pièces de fondation a été suffisamment compacté. Si besoin est, le sol de fondation doit être remplacé par des pierres concassées ou un matériau portant similaire. L'épaisseur du matériau de surface anti-choc est calculée selon la formule indiquée à la page supplémentaire des instructions de fondation.
4. Les instructions d'érection de l'ossature de l'équipement sont indiquées à la page 6. Les images détaillées du montage sont adjointes aux pages d'instruction séparées où elles sont groupées selon le mode de fixation. Des instructions modulaires séparées sont données pour les composants à fixer sur l'ossature. Respecter les mesures données par le fabricant dans les instructions de montage.
5. Vérifier que l'équipement est droit et que sa fondation est solide. Dans le cas des équipements dont la fondation se trouve sous le sol, le sol doit être suffisamment compacté lors du remplissage des trous.
6. Effectuer un contrôle de mise en service conforme au procès-verbal compris dans la livraison avant la mise en service de l'équipement. Ce procès-verbal doit être documenté. Ne pas oublier d'empêcher l'accès à l'équipement jusqu'à ce que celui-ci soit prêt et sûr et que tous les outils de montage aient été enlevés.

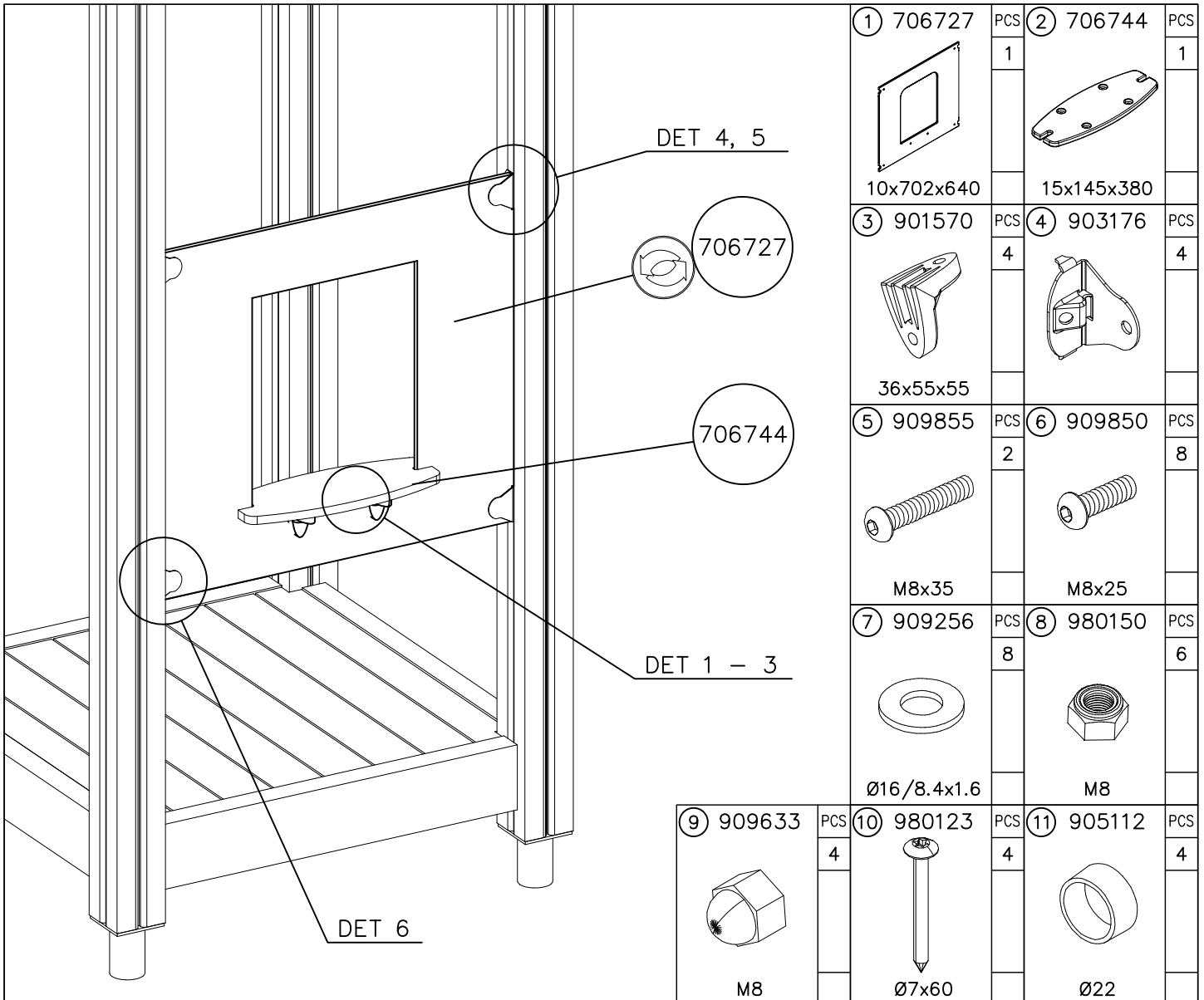

① 706727	PCS	② 706744	PCS
	1		1
10x702x640		15x145x380	
③ 901570	PCS	④ 903176	PCS
	4		4
36x55x55			
⑤ 909855	PCS	⑥ 909850	PCS
	2		8
M8x35		M8x25	
⑦ 909256	PCS	⑧ 980150	PCS
	8		6
Ø16/8.4x1.6		M8	
⑨ 909633	PCS	⑩ 980123	PCS
	4		4
M8		Ø7x60	
		⑪ 905112	PCS
			4
		Ø22	

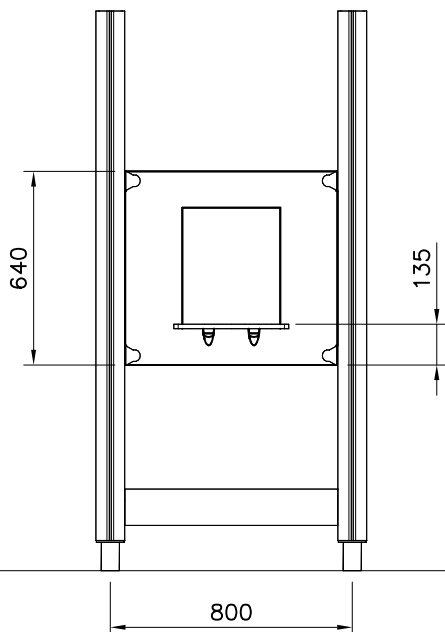

WALL OPTIONS

706727	706727-701	BLUE
	706727-702	YELLOW
	706727-703	LIME
	706727-704	DARK GRAY
	706727-705	LIGHT GRAY
	706727-706	RED
	706727-707	GREEN
	706727-708	FUXIA

WALL OPTIONS

706744	706744	DARK GRAY
15x145x380		

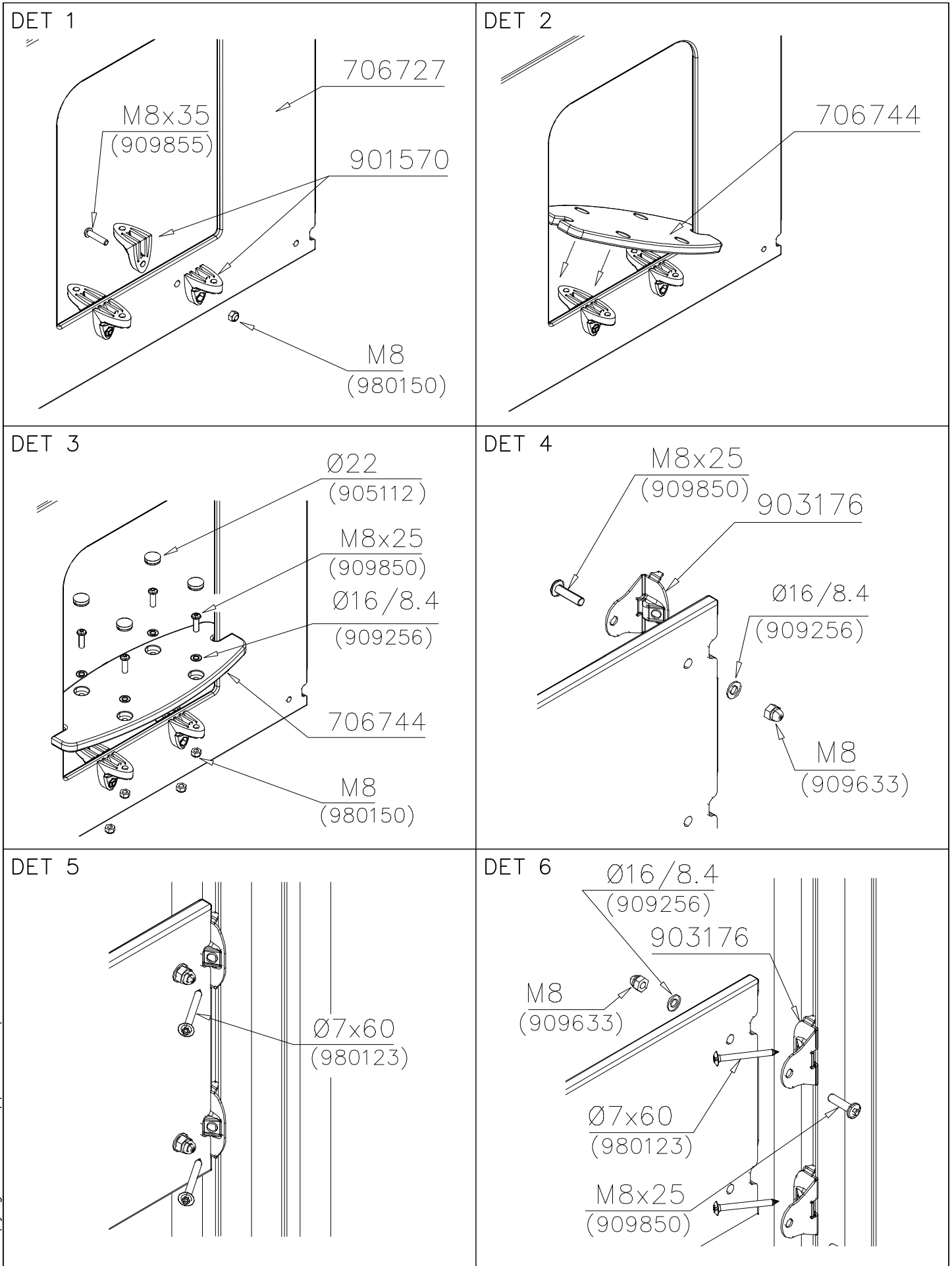

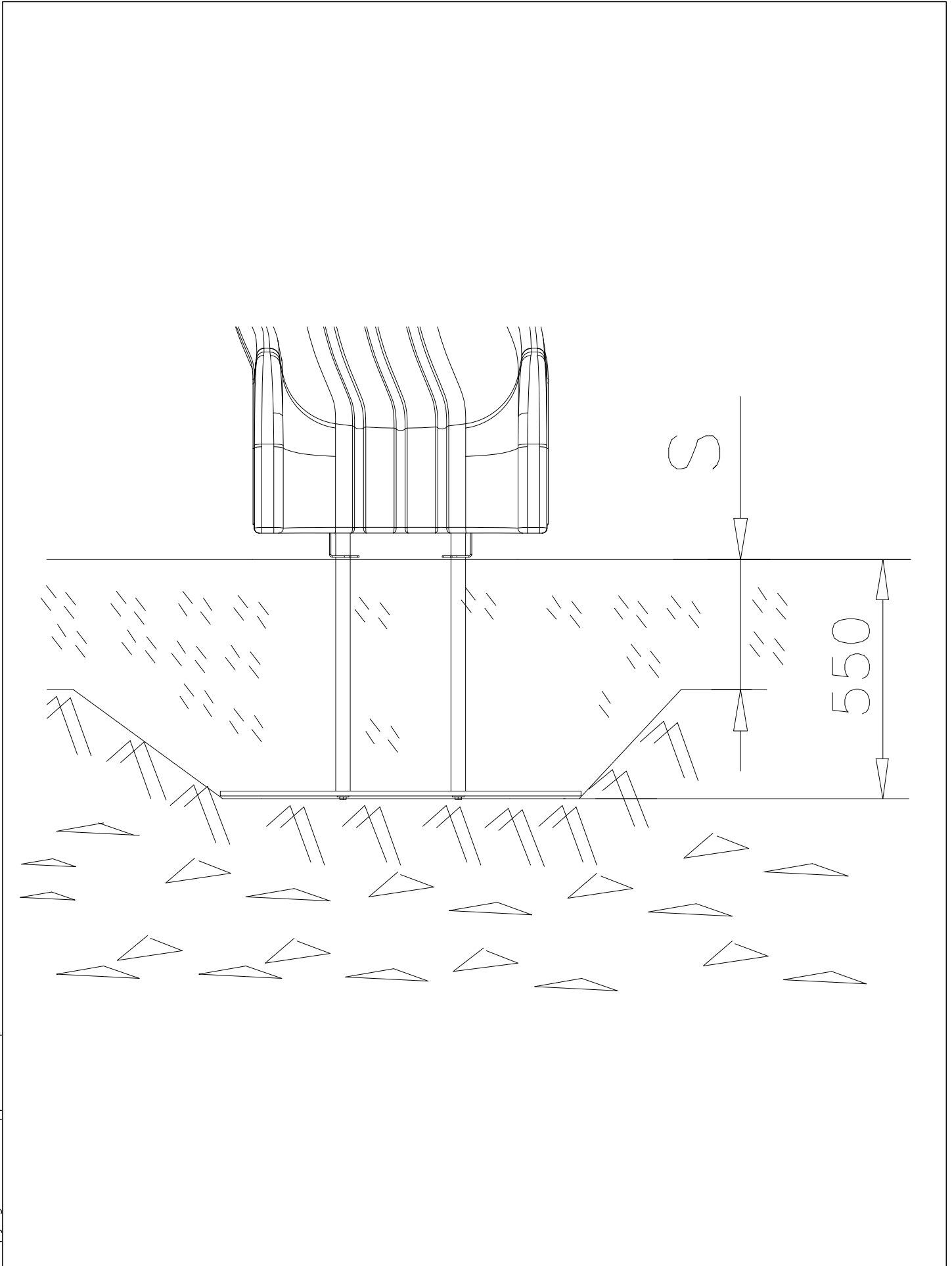

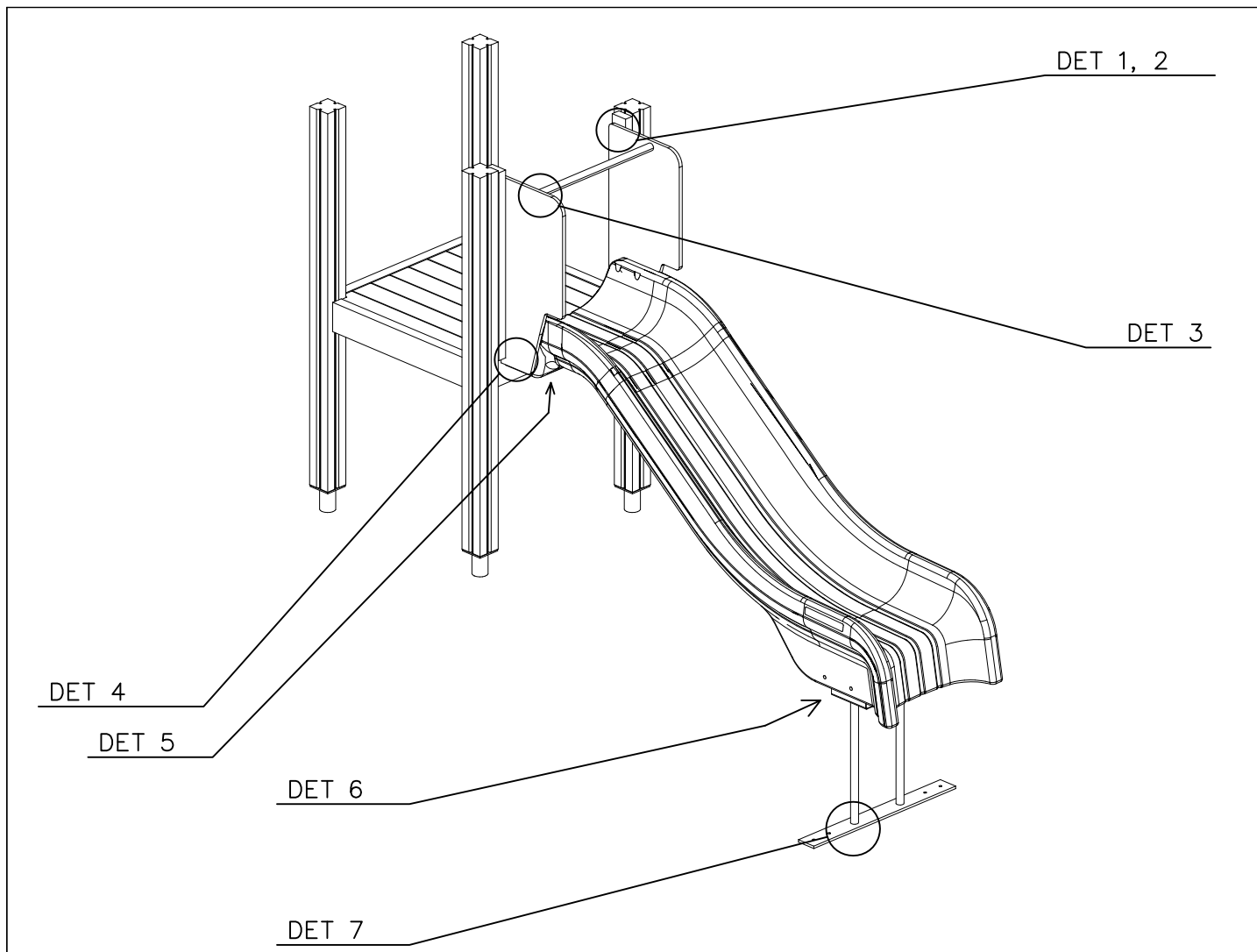

SLIDE OPTIONS

+1470

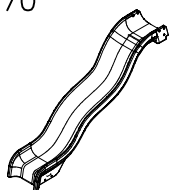

904451 GRAY
 904847 YELLOW

+870

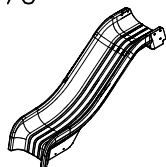

905833 GRAY
 905834 YELLOW

WALL OPTIONS

RIGHT

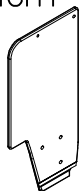





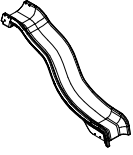
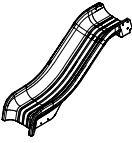

706560-701 BLUE
 706560-702 YELLOW
 706560-703 LIME
 706560-704 DRARK GRAY
 706560-705 LIGHT GRAY
 706560-706 RED
 706560-707 GREEN
 706560-708 FUXIA

LEFT

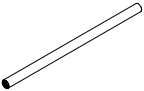
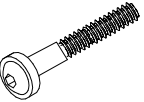
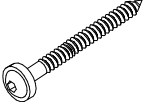
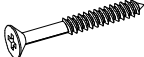
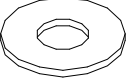
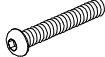
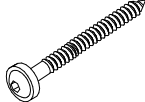

706561-701 BLUE
 706561-702 YELLOW
 706561-703 LIME
 706561-704 DRARK GRAY
 706561-705 LIGHT GRAY
 706561-706 RED
 706561-707 GREEN
 706561-708 FUXIA

○ SLIDE  +1470	PCS 1	○ SLIDE  +870	PCS 1	○ 706560  RIGHT	PCS 1	○ 706561  LEFT	PCS 1	○ 706505  35x70x730	PCS 2	○ 901868  Ø34x598	PCS 1
① 909876  M8x40	PCS 2	② 903093  Ø8x90	PCS 2	③ 980100  Ø5x60	PCS 12	④ 980152  Ø24/8.4	PCS 9	⑤ 909852  M8x30	PCS 6	⑥ 900240  Ø8x70	PCS 3
⑦ 999561  10g	PCS 1										

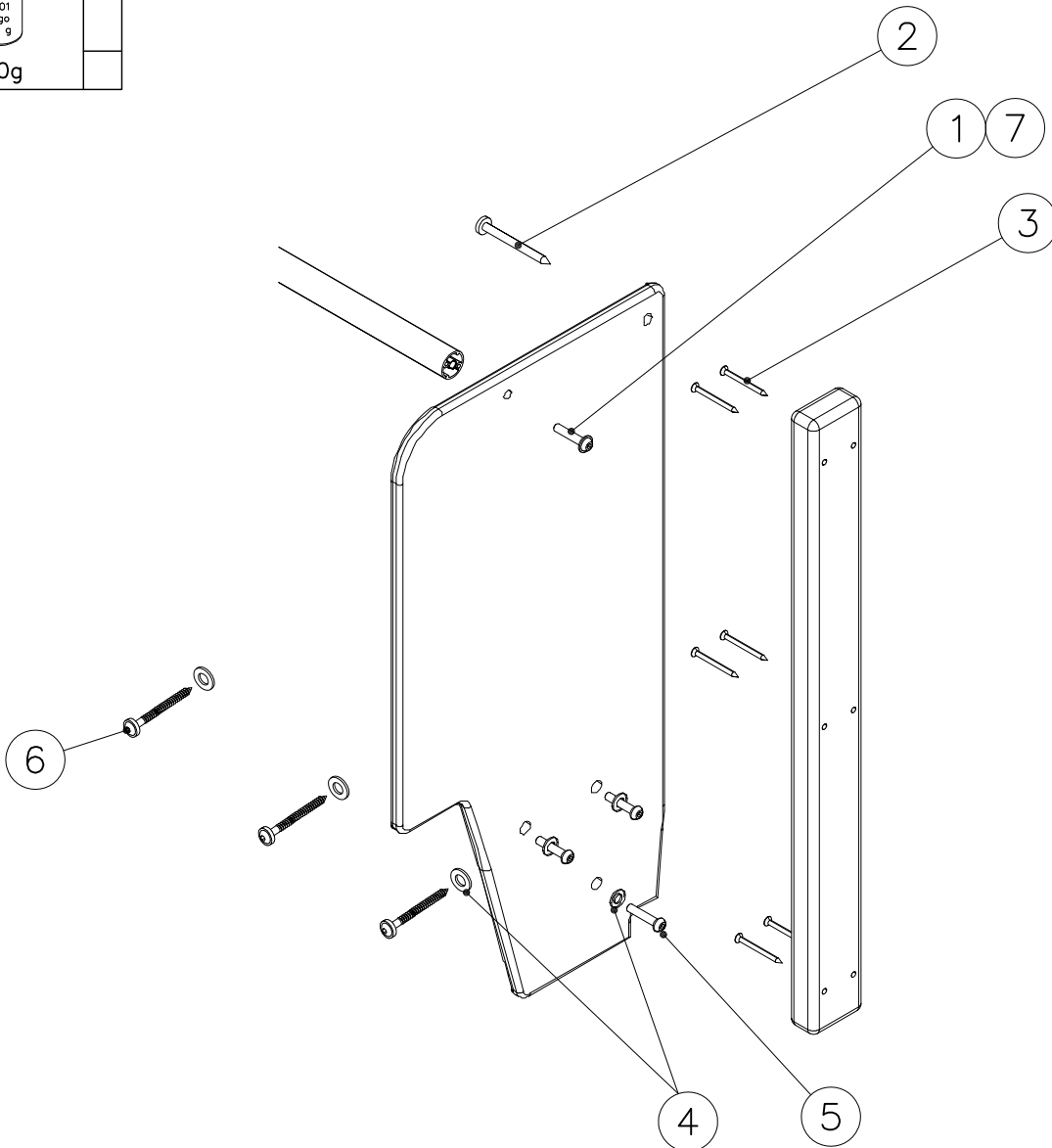

DET 1

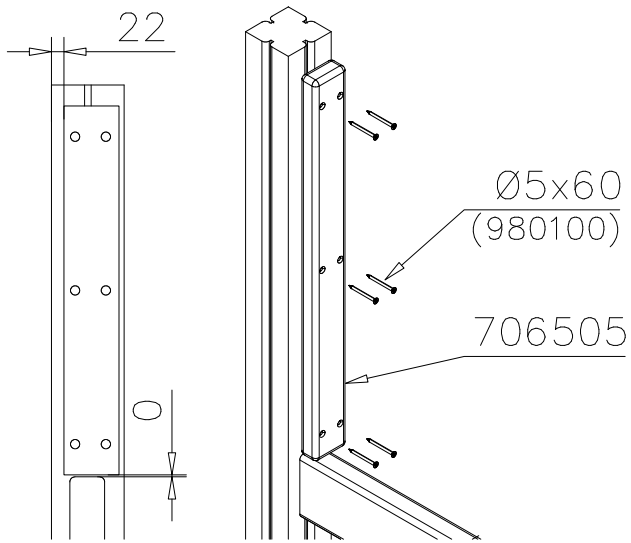

DET 2

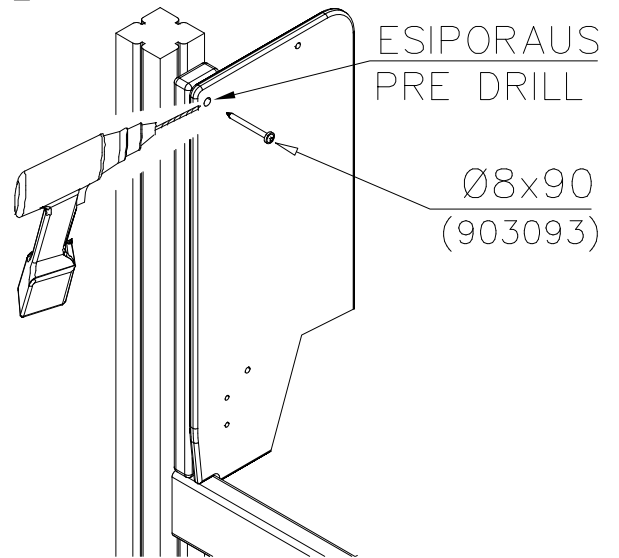

DET 3

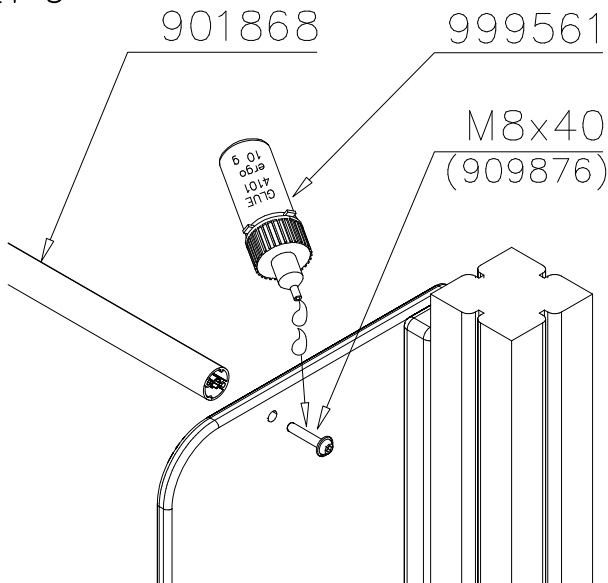

DET 4

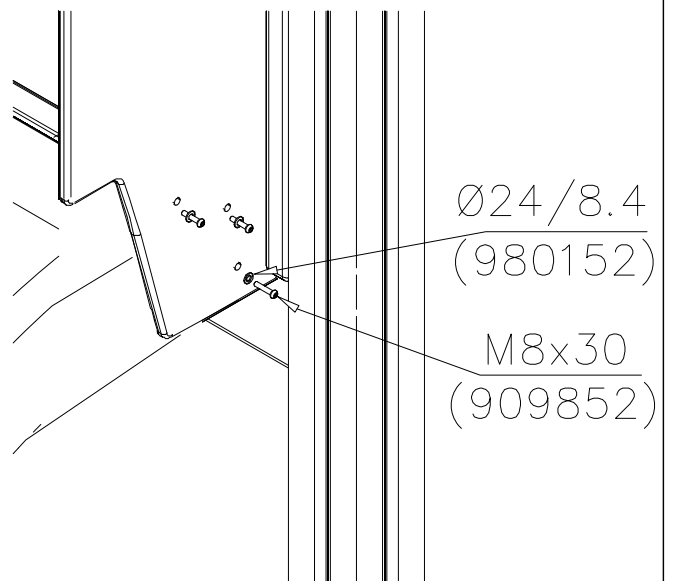

DET 5

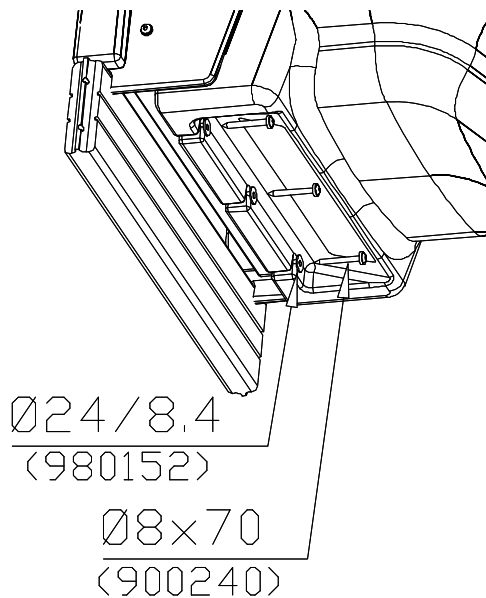





LAPPSET

DEEP FOUNDATION

SLIDE PLASTIC

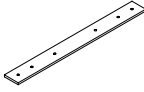
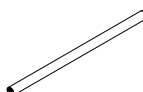
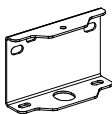
3.11.2017

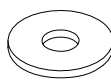
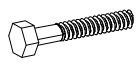
4(5)

○ 707133	PCS 1	○ 901868	PCS 2	○ 908021	PCS 2	⑧ 909210	PCS 4	⑨ 980154	PCS 4	⑩ 905051	PCS 4
											
10x80x745		Ø30x598				M8x40		Ø24/13		Ø24/8.4	
⑪ 909142	PCS 4	⑫ 909644	PCS 4								
											
M12x70		M12									

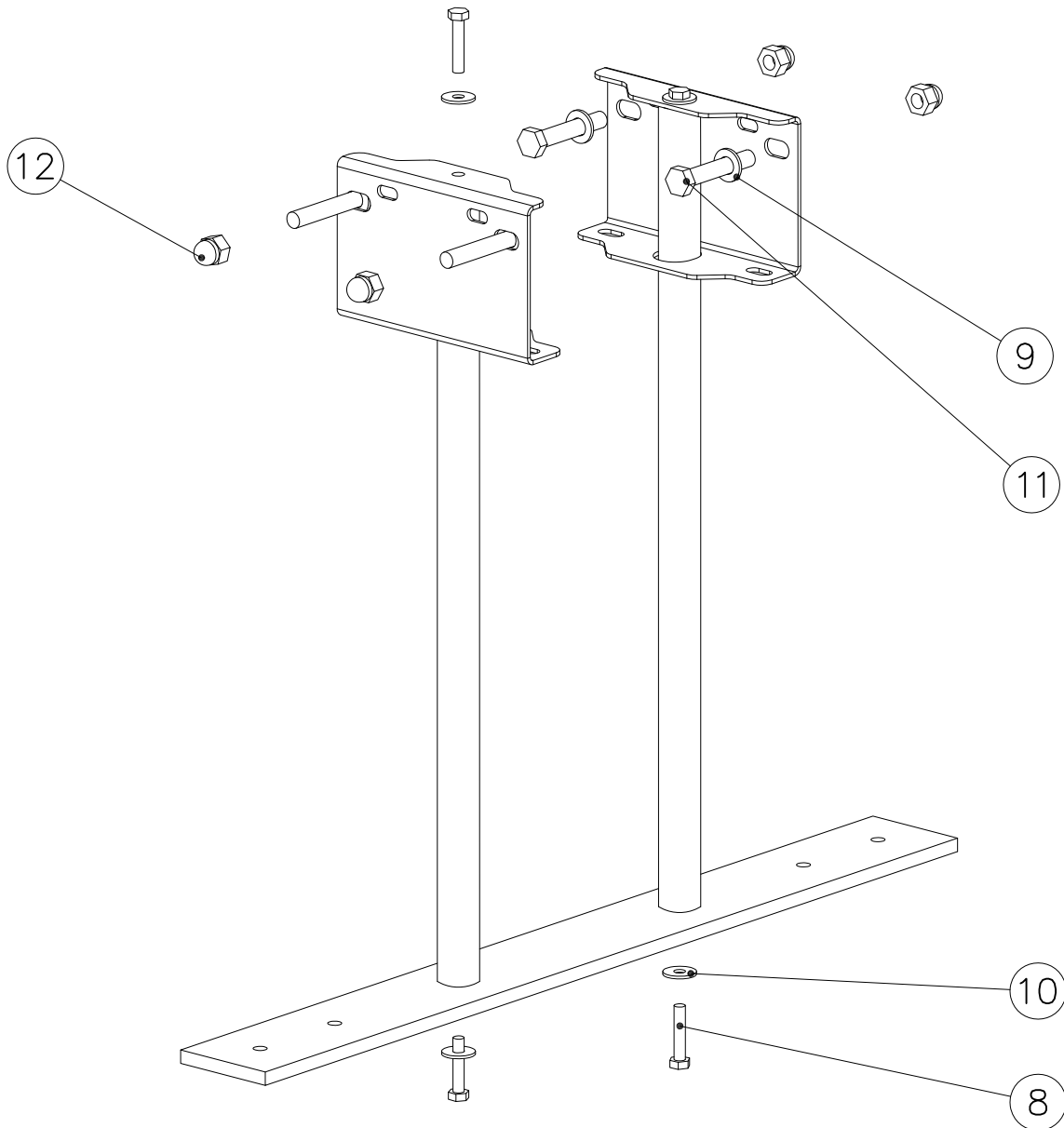

DET 6

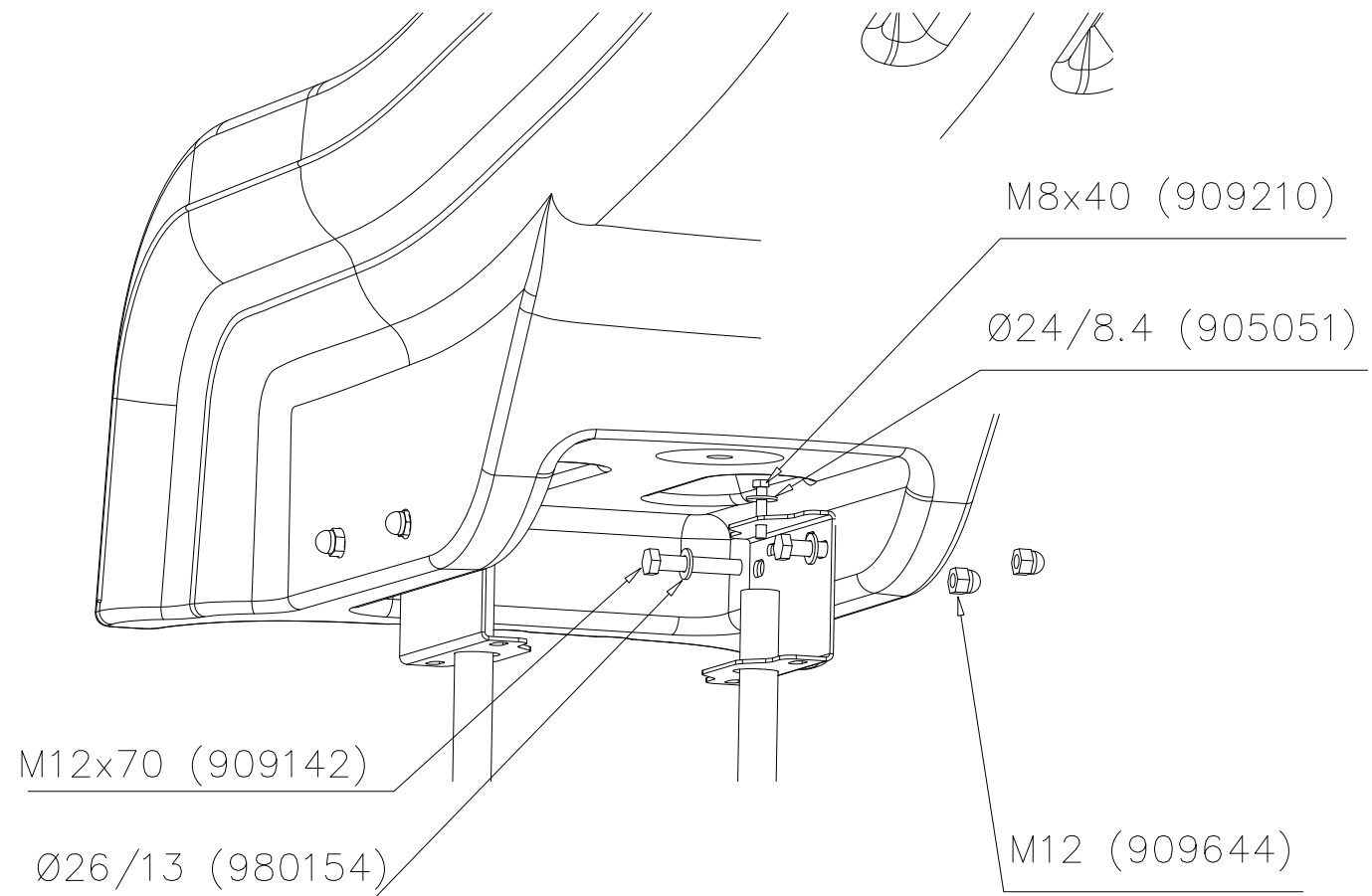

DET 7

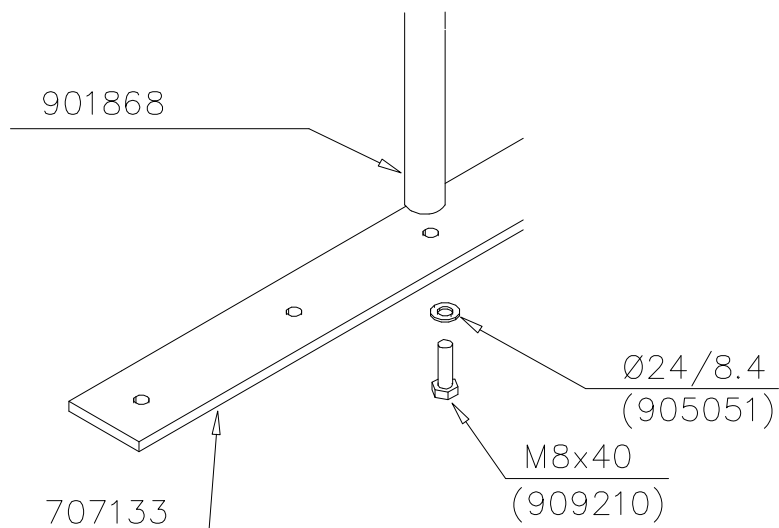

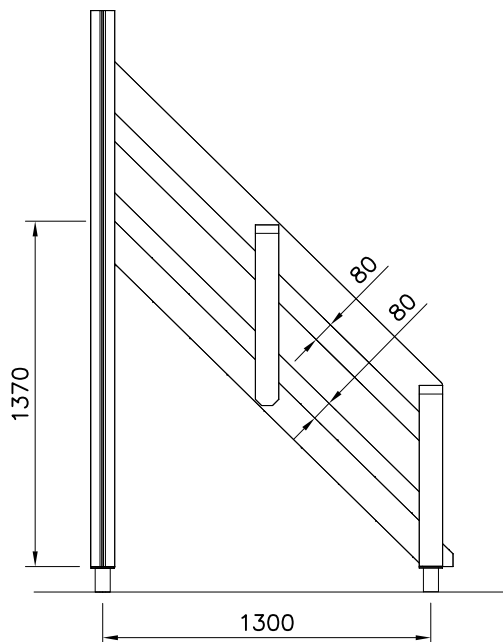
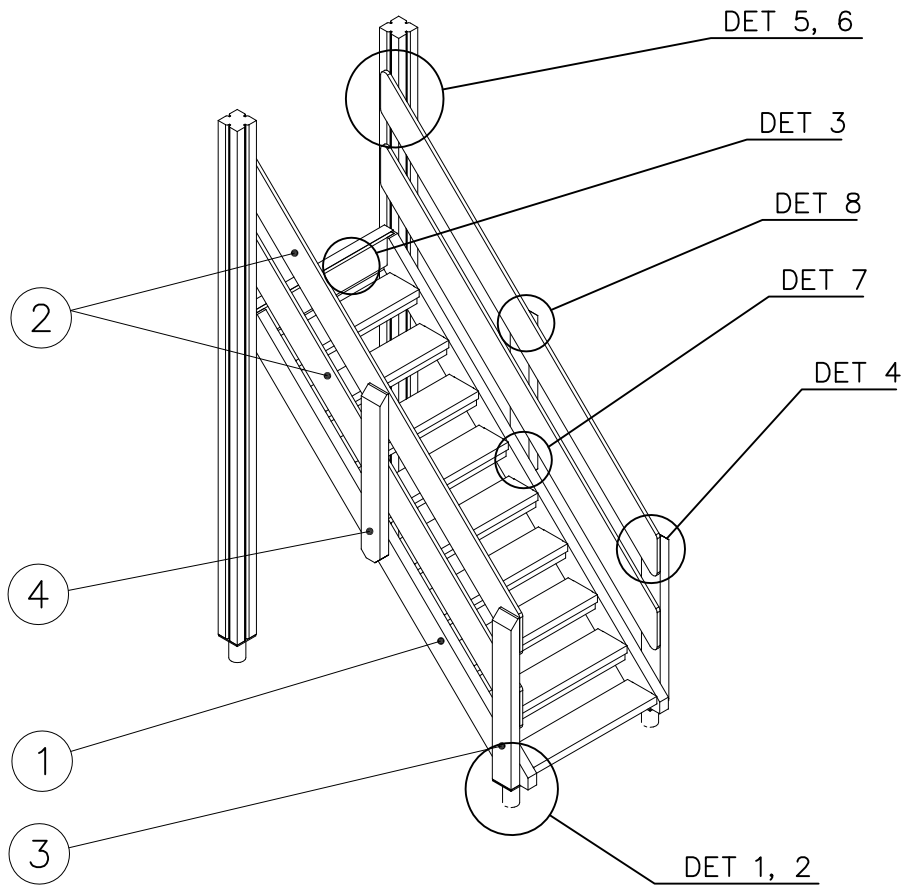

DET 1

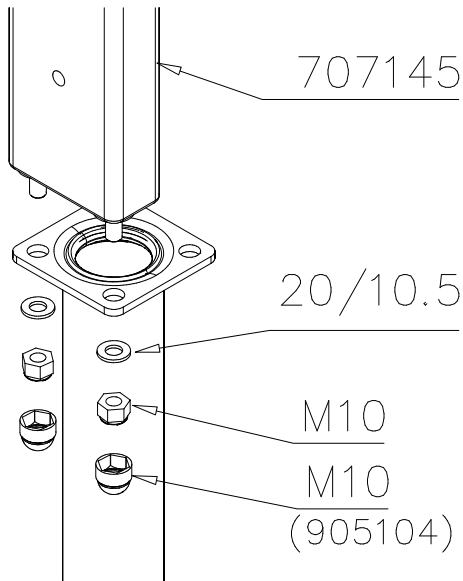

DET 2



DET 3

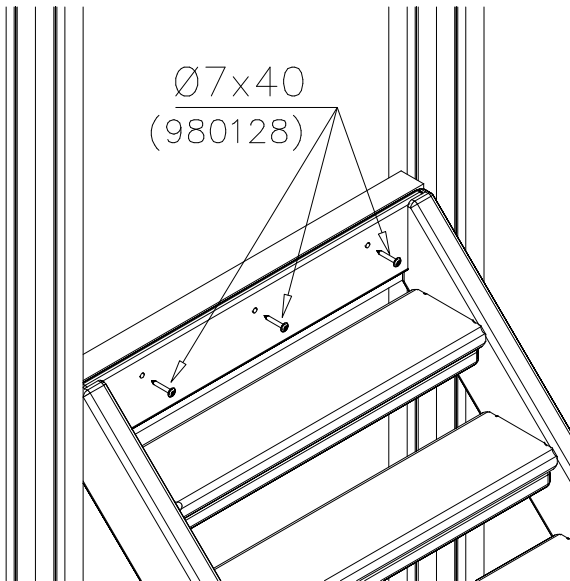

DET 4

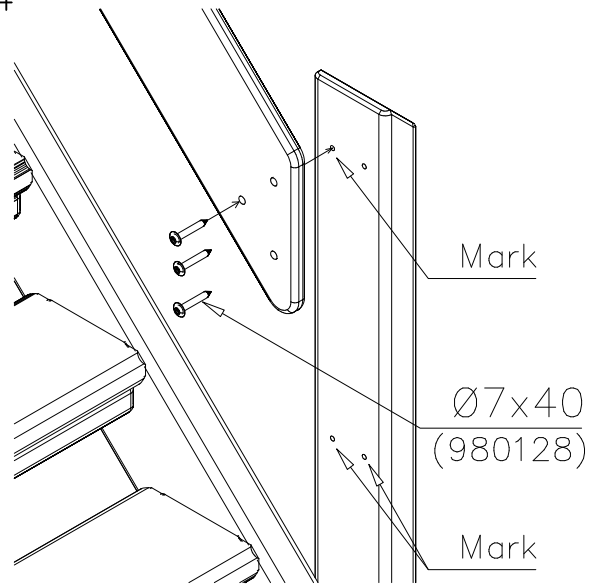

DET 5

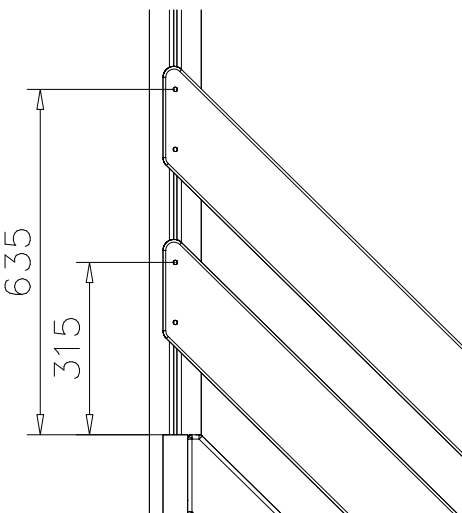

DET 6

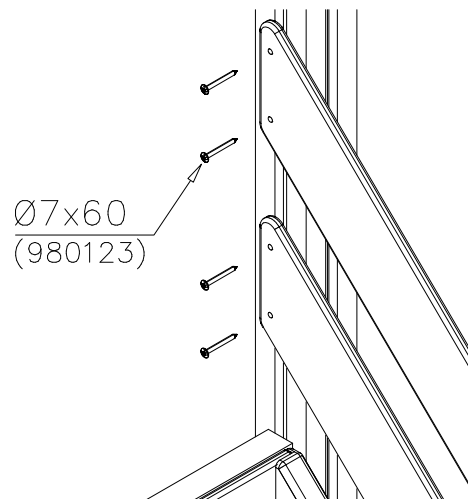

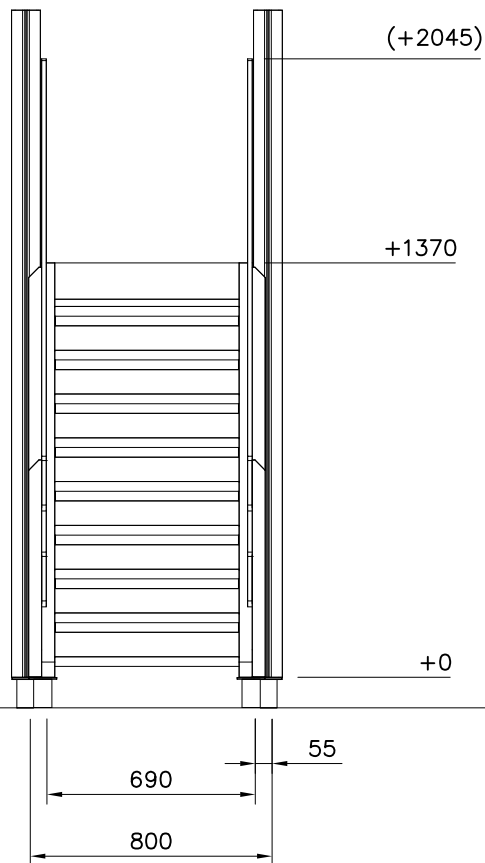
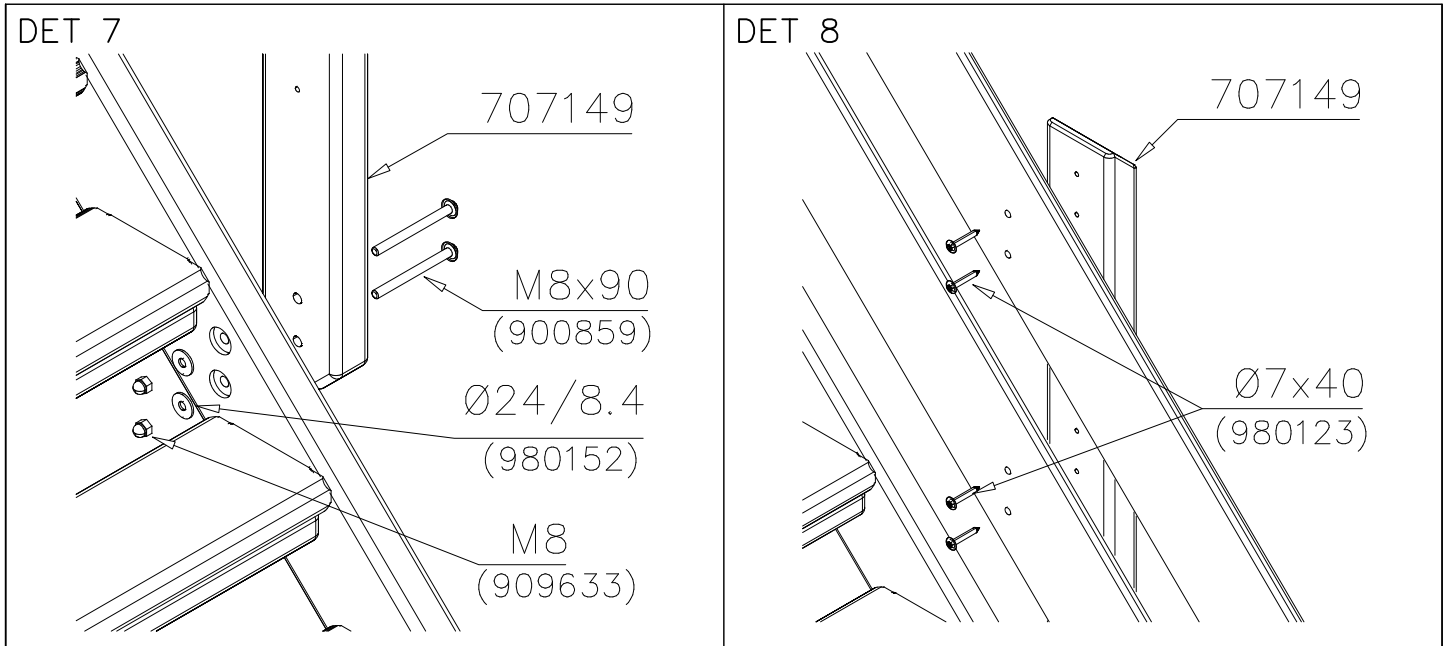



STAIRS OPTIONS +1470

707192 	707192-602 DARK BROWN 707192-603 LIGHT BROWN 707192-604 LIGHT GRAY
---	--









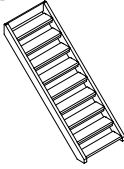

RAILING OPTIONS

RAILS 707152  15x145x2009	707152-701 BLUE 707152-702 YELLOW 707152-703 LIME 707152-704 DARK GRAY 707152-705 LIGHT GRAY 707152-706 RED	707152-707 GREEN 707152-708 FUXIA
---	--	--------------------------------------

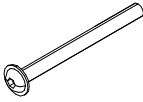
POST 707145  43x93x717	707145-602 DARK BROWN 707145-603 LIGHT BROWN 707145-604 LIGHT GRAY
---	--

POST OPTIONS

POST 707149  43x93x717	707149-602 DARK BROWN 707149-603 LIGHT BROWN 707149-604 LIGHT GRAY
--	--

① 707192  +1470	PCS 1	② 707152  15x145x2009	PCS 4	③ 707145  43x93x717	PCS 2	④ 707149  43x93x717	PCS 2	⑤ 900859  M8x90	PCS 6	⑥ 905104  M10	PCS 4
⑦ 909633  M8	PCS 6	⑧ 980123  Ø7x60	PCS 8	⑨ 980128  Ø7x40	PCS 23	⑩ 980152  Ø24/8.4x2	PCS 6		PCS		PCS

**Tuotekyltti tulee tuotteen mukana yhdellä seuraavista tavoista:****1) Metallinen tuotekyltti ja kiinnitysruuvit**

- Kiinnitä tuotekyltti ruuveilla tolppaan noin 2 metrin korkeuteen kuvan 1 mukaisesti.

2) Tuotekylttitarra

- Puhdista maalattu metalli- tai vaneripinta pölystä ja kosteudesta. Liimaa tarra kuvan 2 mukaisesti.
- Huom. Älä kiinnitä tarraa karheapintaiseen laminaattiin tai maalattuun puuhun.

Vår produktmärkning levereras på ett av följande sätt:**1) Produktskylt i metall**

- Fäst skylten med de medföljande skruvarna

2) Självhäftande produktetikett

- Rengör den pulverlackerade metallytan eller laminatyten så att den blir fri från smuts och fukt. Fäst etiketten enligt fig. 2.
- Obs! Fäst ej etiketten på detaljer med skrovlig yta eller på målat trä.

Product label is delivered by one of following ways:**1) Metal product label and screws**

- Fasten the label with screws.

2) Label sticker

- Clean the painted metal or plywood surface from dirt and moisture. Fasten the sticker as shown in the figure 2.
- Note. Do not attach the sticker to rough surfaced laminate or painted wood.

La plaque d'informations produit est livrée sous l'une de ces 3 formes :**1) Plaque métallique et vis**

- Fixez la plaque à l'aide des vis.

2) Etiquette autocollante

- Avant de coller l'étiquette, nettoyez le composant métallique peint ou la plaque de contreplaqué, de toute saleté. La surface doit être sèche (voir image 2).
- Attention, ne pas coller l'étiquette sur une surface lamellé-collée irrégulière ou sur du bois peint.

Die Auslieferung des Produktaufklebers erfolgt auf eine dieser Arten:**1) Produkt-Schild aus Metall incl. Schrauben**

- Die Befestigung des Schildes erfolgt mittels der Schrauben.

2) Aufkleber

- Entfernen Sie zunächst Schmutz und Feuchtigkeit vom lackierten Metall bzw. von der Holzoberfläche und bringen Sie den Aufkleber wie im Bild oben rechts beschrieben auf den gesäuberten Untergrund auf.
- Beachten Sie: Bringen Sie den Aufkleber nicht auf raues laminiertes oder lackiertes Holz an.