

LAPPSET®

THEME

ASENNUSOHJE
MONTERINGSANSVISNING
INSTALLATION INSTRUCTION
AUFBAUANLEITUNG
NOTICE D'INSTALLATION







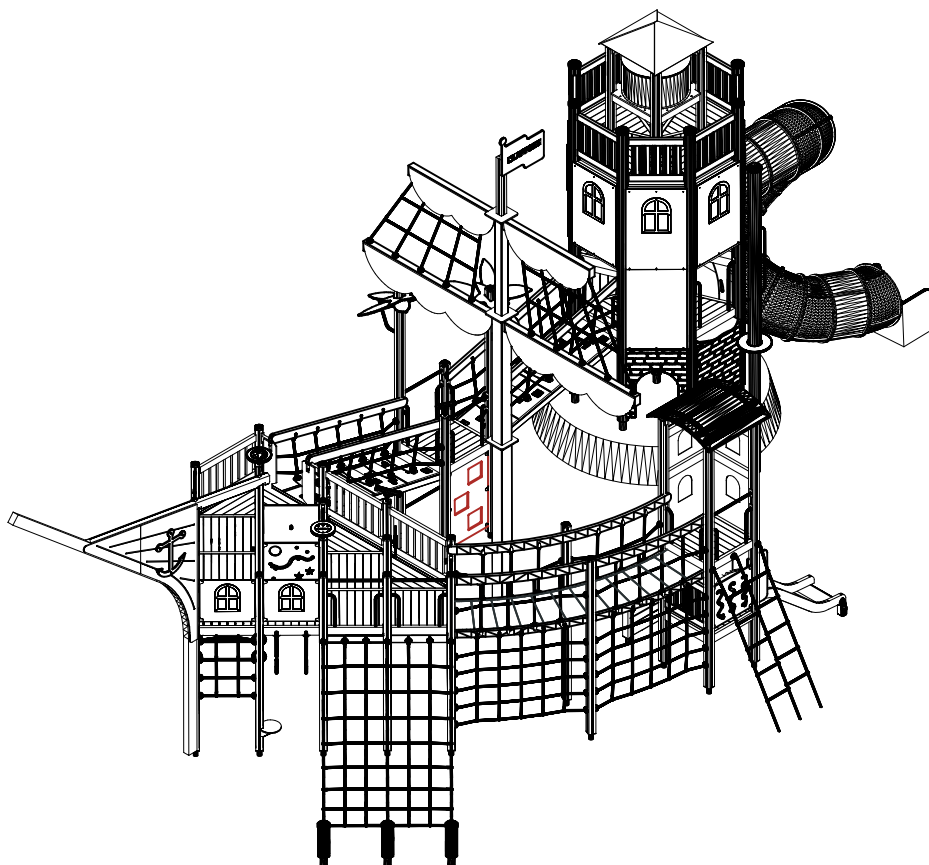



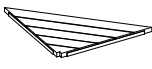
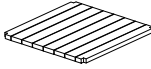
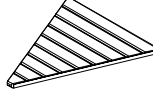

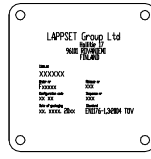
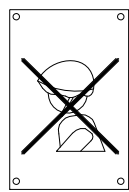
DATE: 25.10.2018

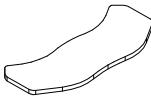
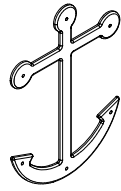
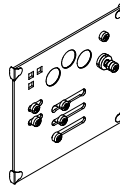
Q12946

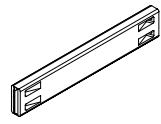
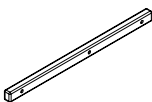
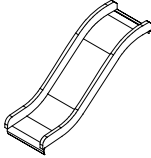
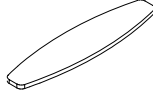

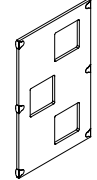
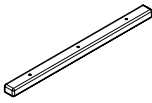
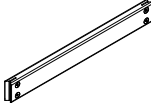
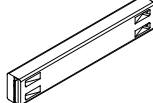
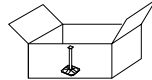
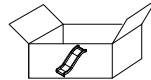
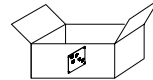
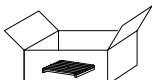
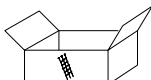
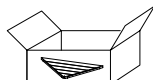
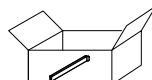
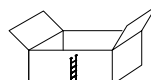
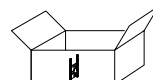
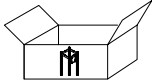
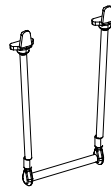
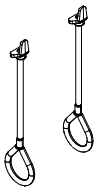
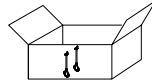
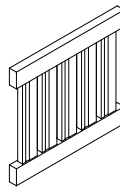
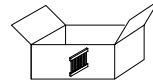
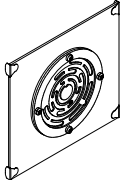
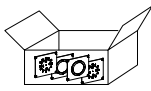
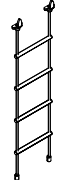







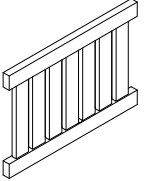
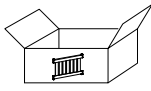
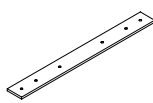

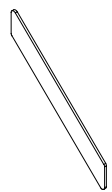
INCLUDES PRODUCTS WHICH
NEED EXPERT KNOWLEDGE OF
CONSTRUCTION TECHNIQUE!

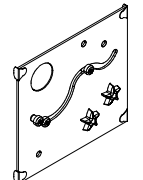
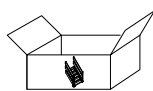
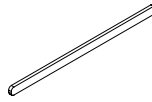
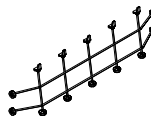
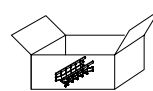

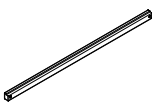
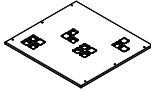
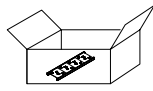
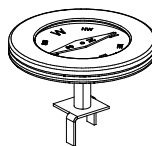
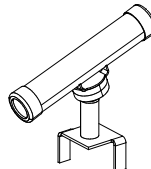
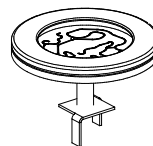
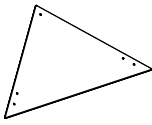
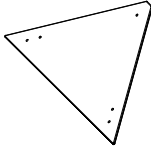
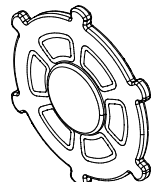
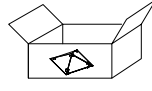
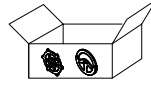
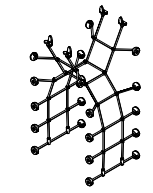
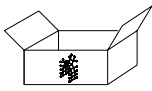
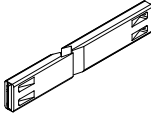
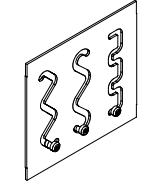

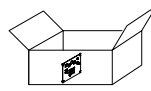
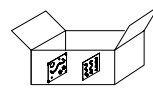

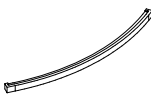
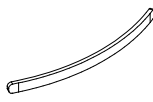
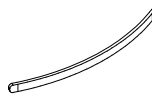
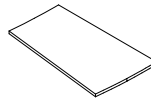
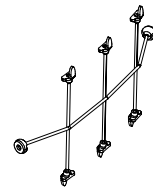
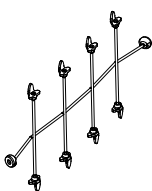
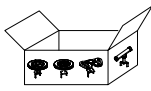
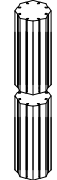
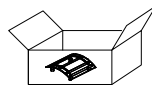
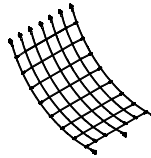





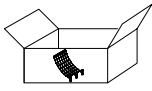
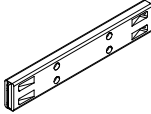
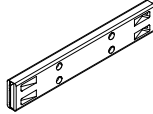

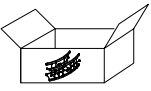
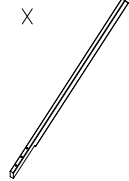
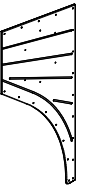
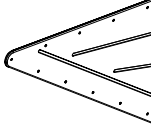
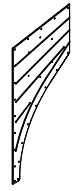
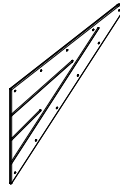
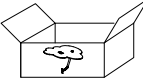
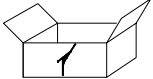
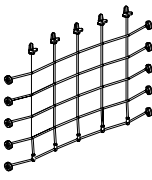
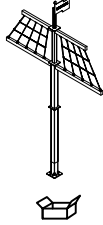
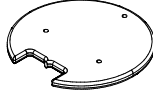
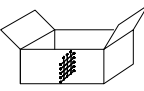
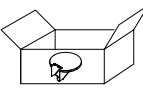
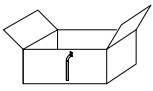
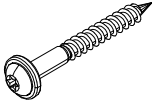
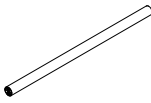
DATE: 26.9.2018

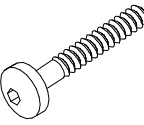
008985	PCS 4	008986	PCS 11	700400	PCS 19	701401	PCS 5	702286	PCS 1	702339	PCS 1
											
32x714x714		750x750				L 1250		65x65		118x78	
703703	PCS 1	703767	PCS 1	704868-605	PCS 2	705705-706	PCS 1	706371-701	PCS 2	706439	PCS 82
											
						10x640x702		15x345x750		L 704	
706443	PCS 41	706452	PCS 1	706453	PCS 10	706484	PCS 2	706505	PCS 2	706507-706	PCS 1
											
32x45x702		600x780x1470		15x145x600		93x93x2150		35x70x730			
706508	PCS 12	706510	PCS 4	706512	PCS 4	706531	PCS 32	706533	PCS 1	706534	PCS 5
											
32x45x650		45x120x1030		70x120x704							
706535	PCS 11	706536	PCS 1	706537	PCS 4	706538	PCS 4	706546	PCS 1	706558	PCS 1
											
706559	PCS 1	706600-305	PCS 1	706735-305	PCS 4	706742	PCS 4	706746-607	PCS 9	706748	PCS 9
											
								45x640x701			
706766-701	PCS 1	706778	PCS 1	706780-305	PCS 1	706788	PCS 6	706790	PCS 1	706810	PCS 19
											
						93x93x3700		93x93x3500		93x93x2650	

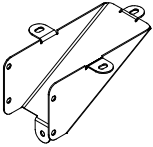
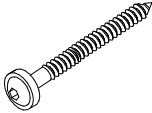
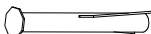
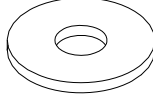
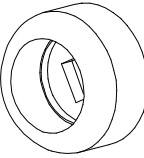
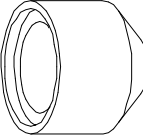
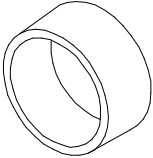

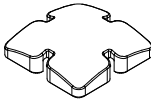
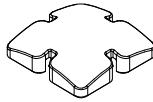
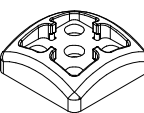
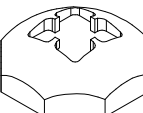
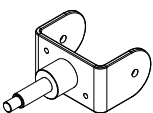

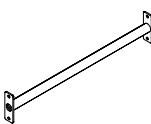

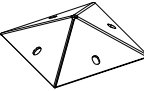
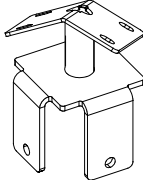
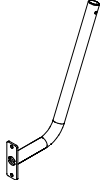



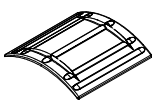
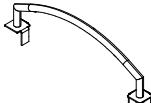
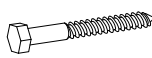
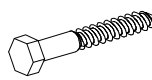
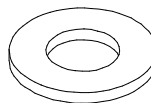
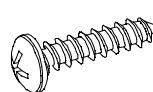

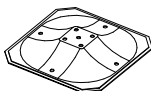
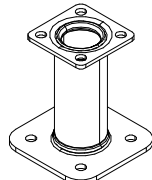
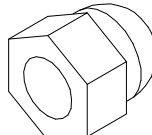
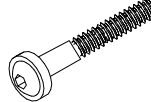

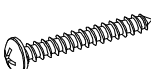

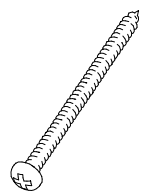
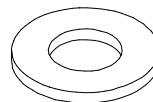

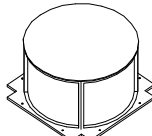

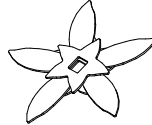

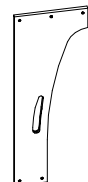
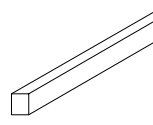
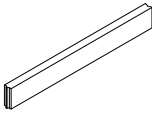
DATE: 26.9.2018

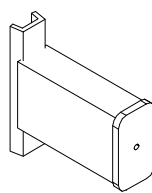
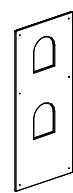
706997  45x640x984	PCS 3	706999 	PCS 3	707133  10x80x745	PCS 1	707145  43x93x717	PCS 2	707146-701  15x145x1153	PCS 4	707154  93x93x900	PCS 1
707191  +870	PCS 1	707209-701  10x640x702	PCS 1	707224 	PCS 1	707255-603  45x120x2480	PCS 4	707260-305  2375x600	PCS 4	707268  	PCS 2
707271  70x95x2480	PCS 4	707272-701  15x630x590	PCS 8	707284 	PCS 2	707303-701 	PCS 1	707304 	PCS 2	707305-703 	PCS 1
707316-704 	PCS 2	707317-704 	PCS 2	707320-702 	PCS 1	707329 	PCS 1	707333 	PCS 1	707341-305  1520x705	PCS 1
707349 	PCS 1	707374  L 1504	PCS 1	707386-706  10x640x702	PCS 1	707393-305  +1970	PCS 1	707449 	PCS 1	707450 	PCS 2
707518-603 	PCS 1	707519-603 	PCS 1	707520-603 	PCS 1	707521-603 	PCS 1	707522-701 X 	PCS 12	707525-305 	PCS 2
707528-305 	PCS 2	707585 	PCS 4	707597-603  140x140x450	PCS 3	707623 	PCS 1	707630-305  1600x2810	PCS 1	707634-603  90x145x3233	PCS 1

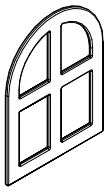
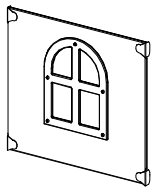
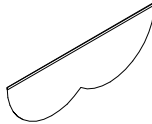
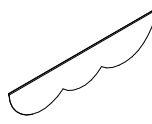
DATE: 26.9.2018

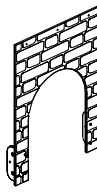
707635  1 1	707637  4 45x120x704	707637-602  2 45x120x704	707643  1 125x793x3700	707644  1 1	707646 X  1 90x145x4073
707657  1 15x2239x1000	707658  1 15x1000x721	707660  1 15x2239x1000	707661  1 15x1000x721	707665  2 2	707685  1 1
707686-305  2 1350x1240	707694  1 1	707696-704  2 2 15x265x275	707699  2 2	707729  2 2	707732  24 24
900240  225 225 Ø8x70	901868  3 3 Ø34x598	901879  2 2	901899  72 72 M8x45	901902  4 4 30.7x60.9x100	902086  2 2 148x172x254
903093  520 520 Ø8x90	903112  12 12 L 750	905051  111 111 Ø24/8.4	905083  16 16 Ø32	905104  96 96 M10	905112  16 16 Ø22
905125  8 8 Ø10.7	905138  20 20 GRAY	905139  11 11 69x69x20	905196  20 20 GRAY	905197  11 11 147x147x56.5	905879  1 1
907688-216  2 2	907694-216  10 10 L 704	907701-216  22 22	908187-216  1 1	908188-216  4 4	908207-216  2 2 336x392x40

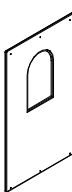
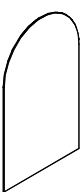
DATE: 26.9.2018

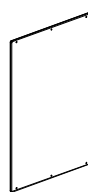
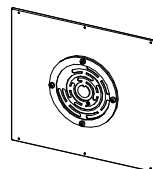
908251  1100x1100x215	PCS 1	908330-216 	PCS 2	909217  8x70	PCS 111	909235  Ø8x60	PCS 14	909256  Ø16/8.4x1.6	PCS 4	909506  Ø3.5x13	PCS 4
909511  90x90x650	PCS 32	909519 	PCS 34	909531  130x130x150	PCS 4	909633  M8	PCS 10	909867  M8x70	PCS 4	980101  Ø4.5x70	PCS 152
980108  Ø4x25	PCS 55	980114  Ø4x20	PCS 4	980123  Ø7x60	PCS 20	980128  Ø7x40	PCS 185	980131  Ø6x60	PCS 124	980151  Ø16/8,4	PCS 14
980160  M8	PCS 48	A10020-4 	PCS 1	A10320  	PCS 1	AG0275  	PCS 2	P02510 	PCS 2	P06520  45x95x778	PCS 37
P10068  45x120x970	PCS 37	P10089  32x45x750	PCS 38	P10496 	PCS 2	P10497 	PCS 2	P12998  15x702x1760	PCS 2	P12999 	PCS 4
P13000 	PCS 4	P13003  10x640x702	PCS 5	P13004 	PCS 2	P13005 	PCS 2	P13009 	PCS 4	P13011 	PCS 3
P13017  140x140x4400	PCS 9	P13019  15x775x1300	PCS 7	P13020 	PCS 7	P13021 	PCS 7	P13022  15x775x1240	PCS 5	P13023-706 	PCS 1

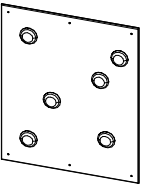
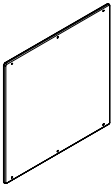
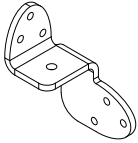
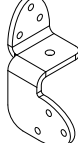
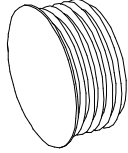
P13026 	PCS 1	P13027  15x775x765	PCS 2	901572 	PCS 1	901573 	PCS 1	905103 	PCS 2		PCS
	PCS		PCS		PCS		PCS		PCS		PCS
	PCS		PCS		PCS		PCS		PCS		PCS
	PCS		PCS		PCS		PCS		PCS		PCS
	PCS		PCS		PCS		PCS		PCS		PCS
	PCS		PCS		PCS		PCS		PCS		PCS
	PCS		PCS		PCS		PCS		PCS		PCS

- EN/AS Impact Area 116.2 m²
- Falling Space 122.7 m²
- Grid size = 1000mm

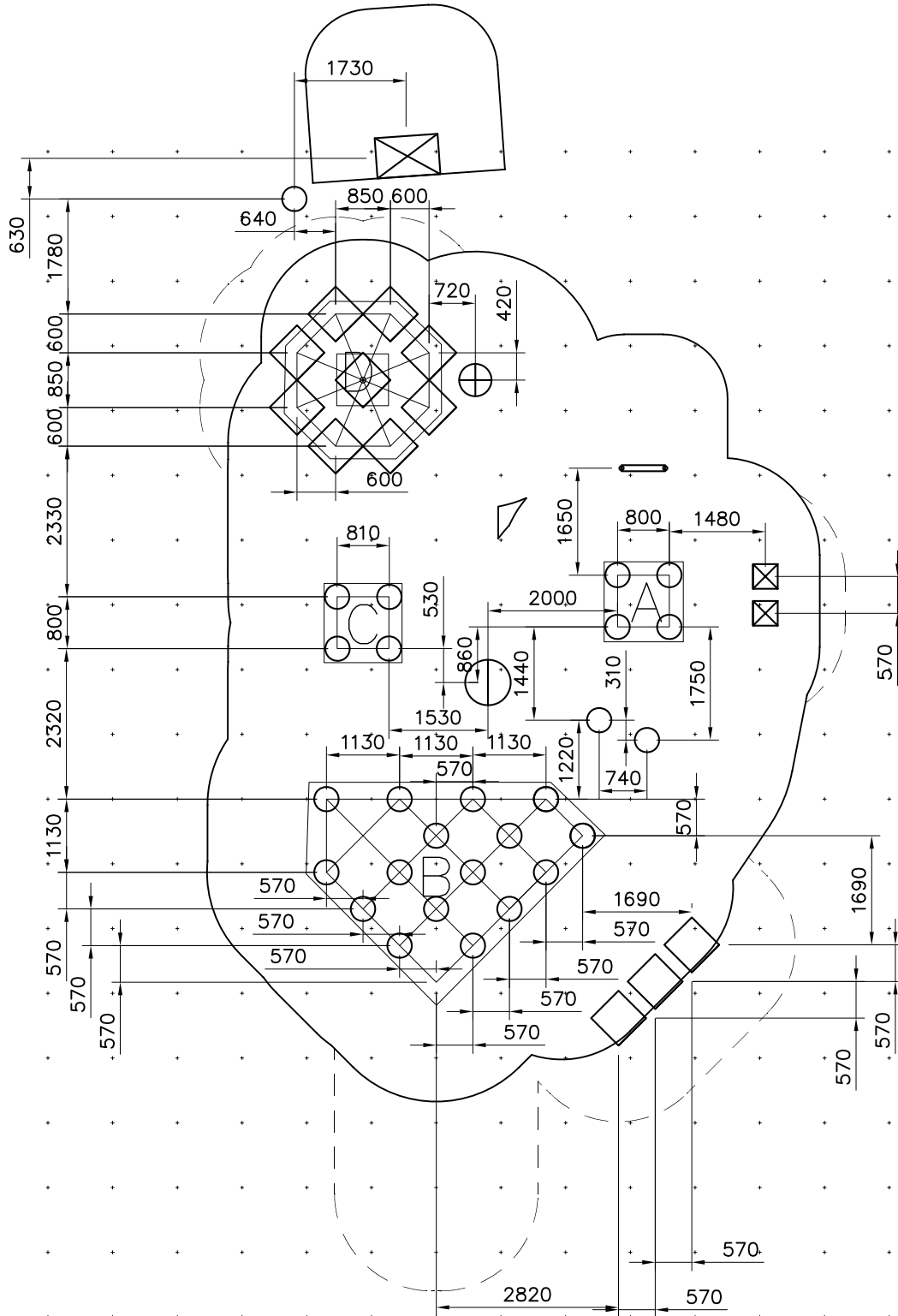

<p>M10 905104</p>	<p>100 S 600</p>	<p>S 600</p>
<p>(3x) Ø8 rebar rings Concrete 500x500x1000</p> <p>1000 1370 S</p>	<p>Ø7x40 901879</p> <p>Hoxl Slide sheet gap Liukupeltti rako.</p>	<p>M12x40 Ø24/13</p>
<p>Sand 0.2-2 mm/ Gravel 2-8 mm Concrete 500x500x200</p> <p>150 S 600</p>	<p>M10 905104 903112</p>	<p>Access- and maintenance panel. Asennus- ja huolto luukku.</p>
<p>M12 10x30 909545</p>	<p>100 S 600</p>	<p>300 S</p>

- EN/AS Impact Area 104.3 m²
- - - Falling Space 123.8 m²
Max Falling Height 1970 mm

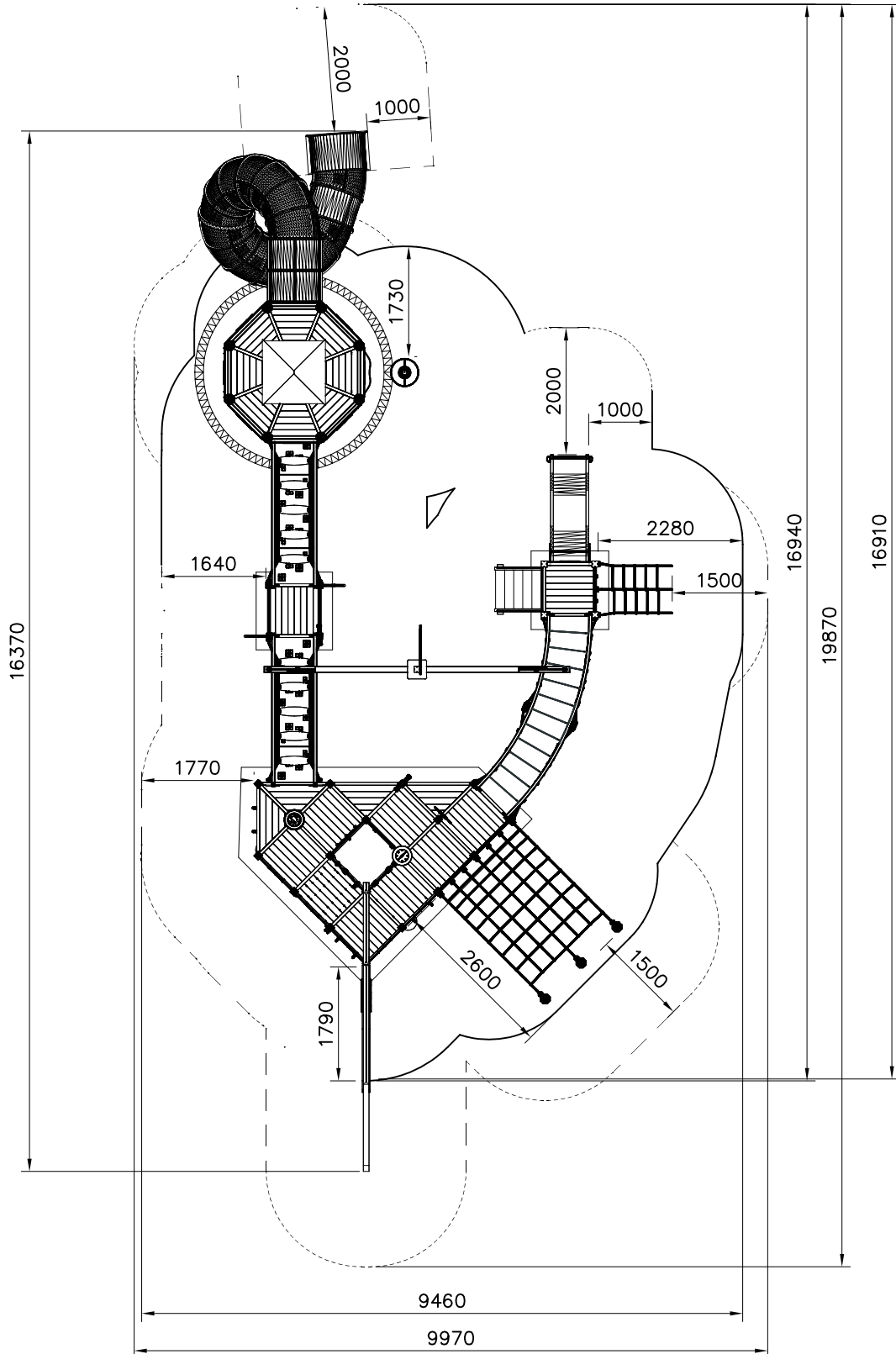
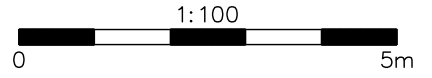

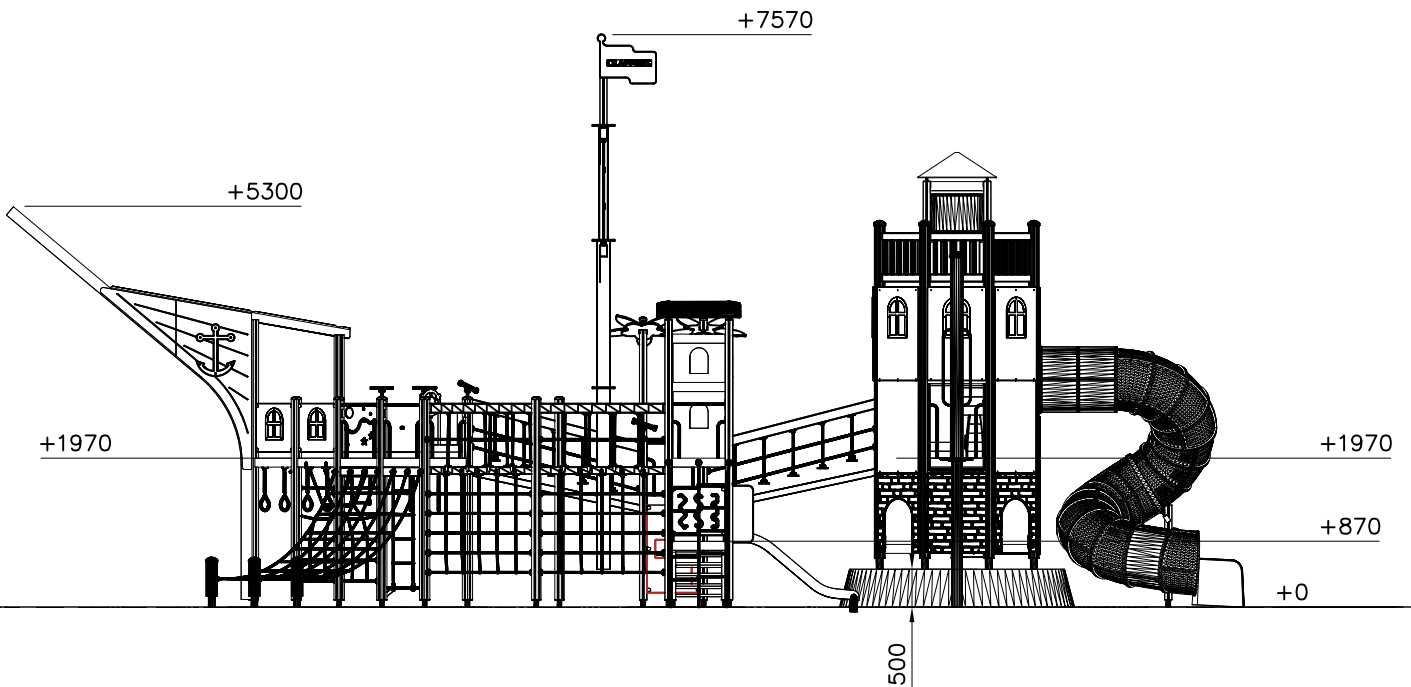
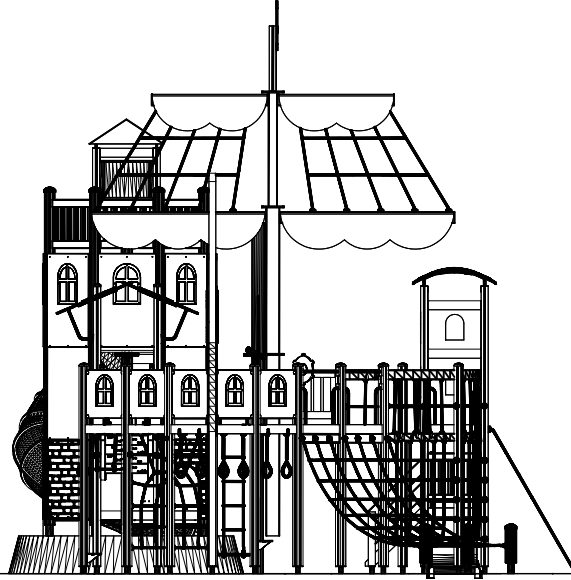

NOTICE!
Fasten the sails before mounting the mast! See DET 12.

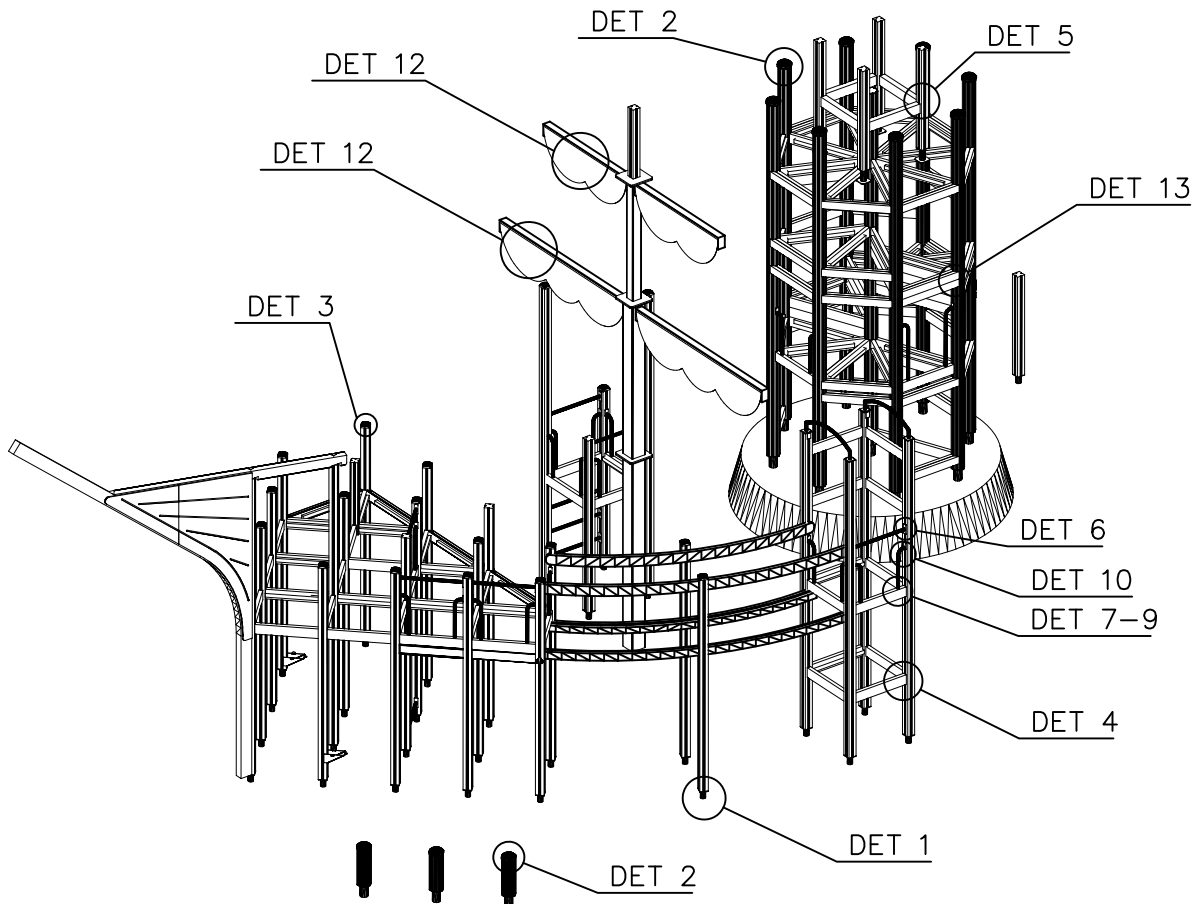
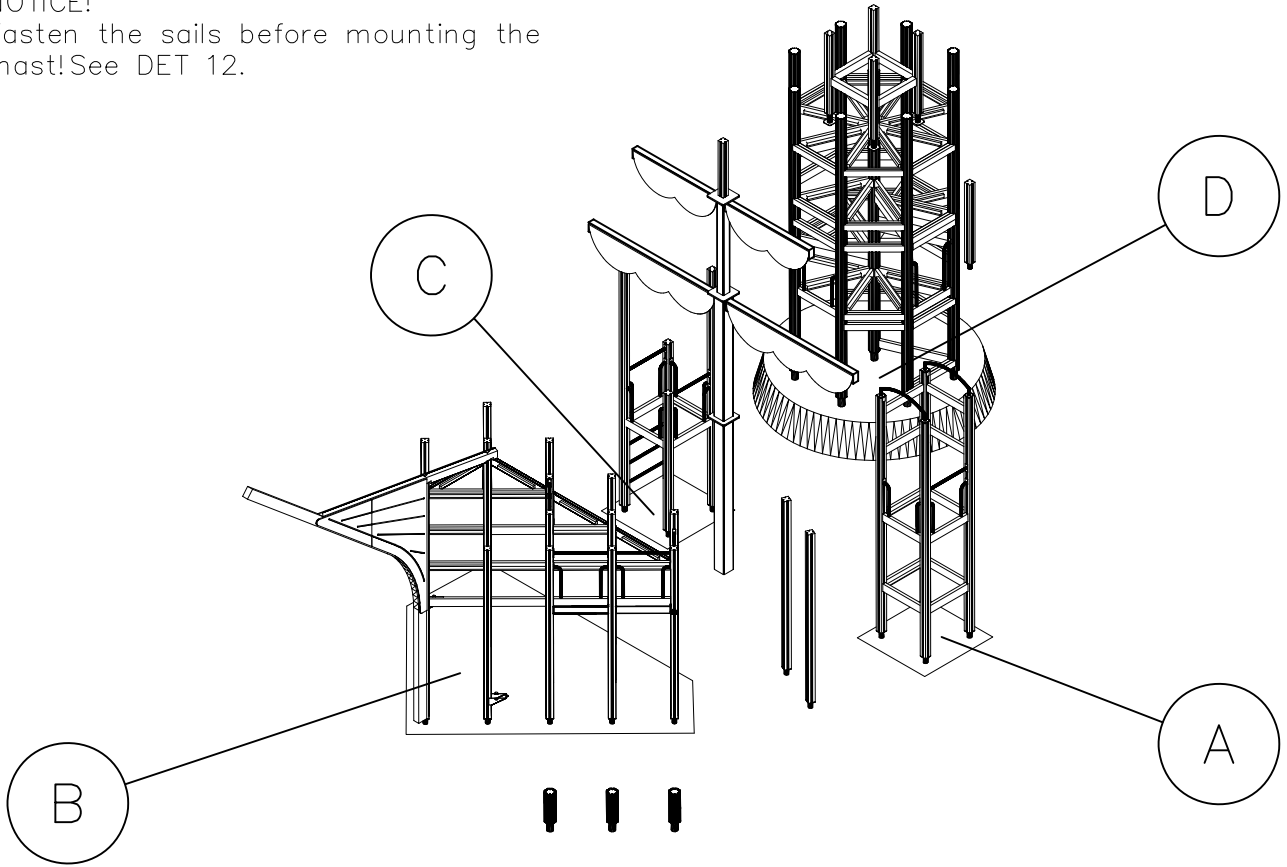

<p>DET 1</p>	<p>DET 2</p>	<p>DET 3</p>	<p>DET 4</p>
<p>DET 5</p>	<p>DET 6</p>	<p>DET 7</p>	<p>DET 8</p>
<p>DET 9</p>	<p>DET 10</p>	<p>DET 11</p>	<p>DET 12</p>
<p>DET 13</p>	<p>DET 14</p>	<p>DET 15</p>	<p>DET 16</p>
<p>DET 17</p>	<p>DET 18</p>	<p>DET 19</p>	<p>DET 20</p>

DET 18

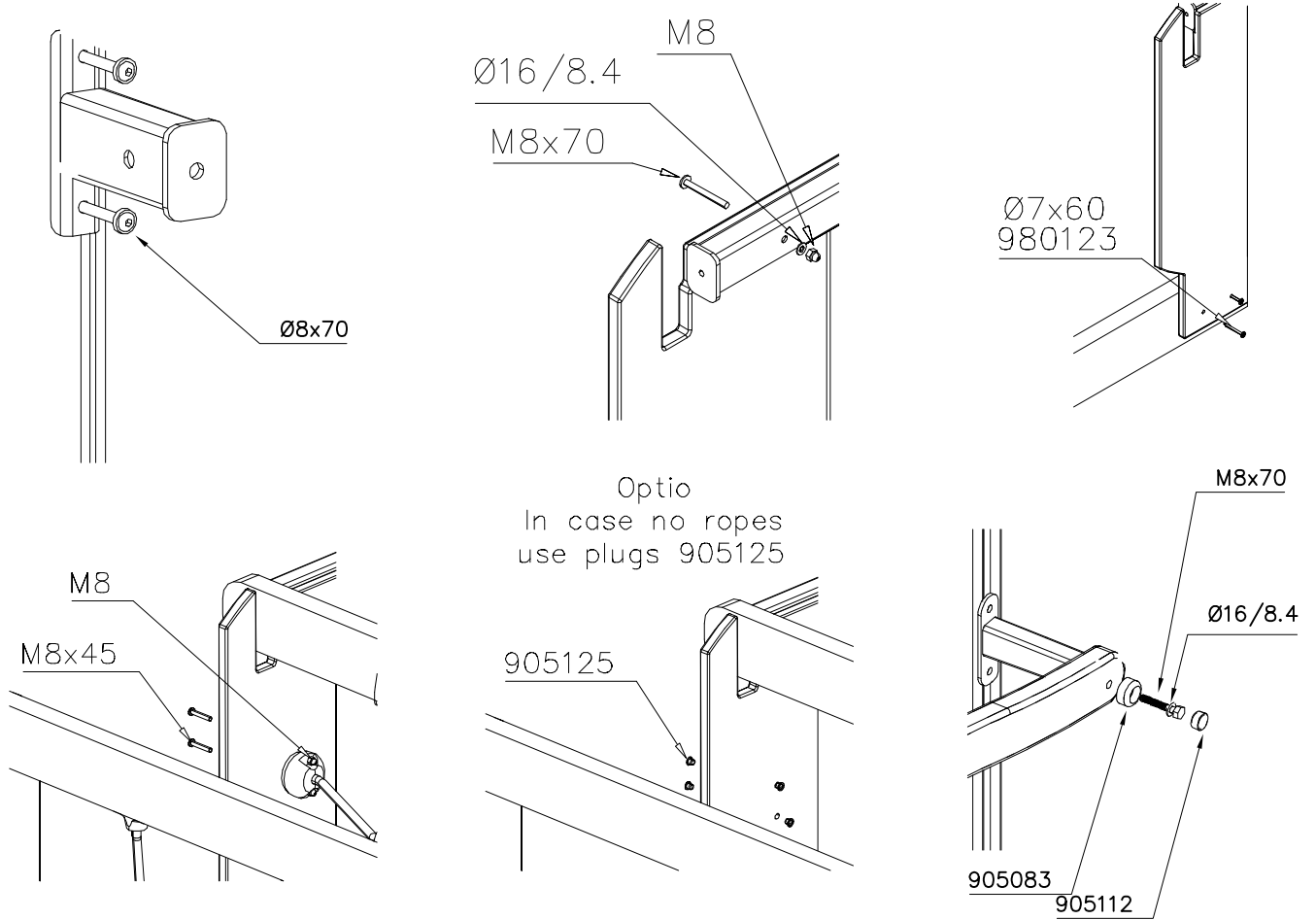

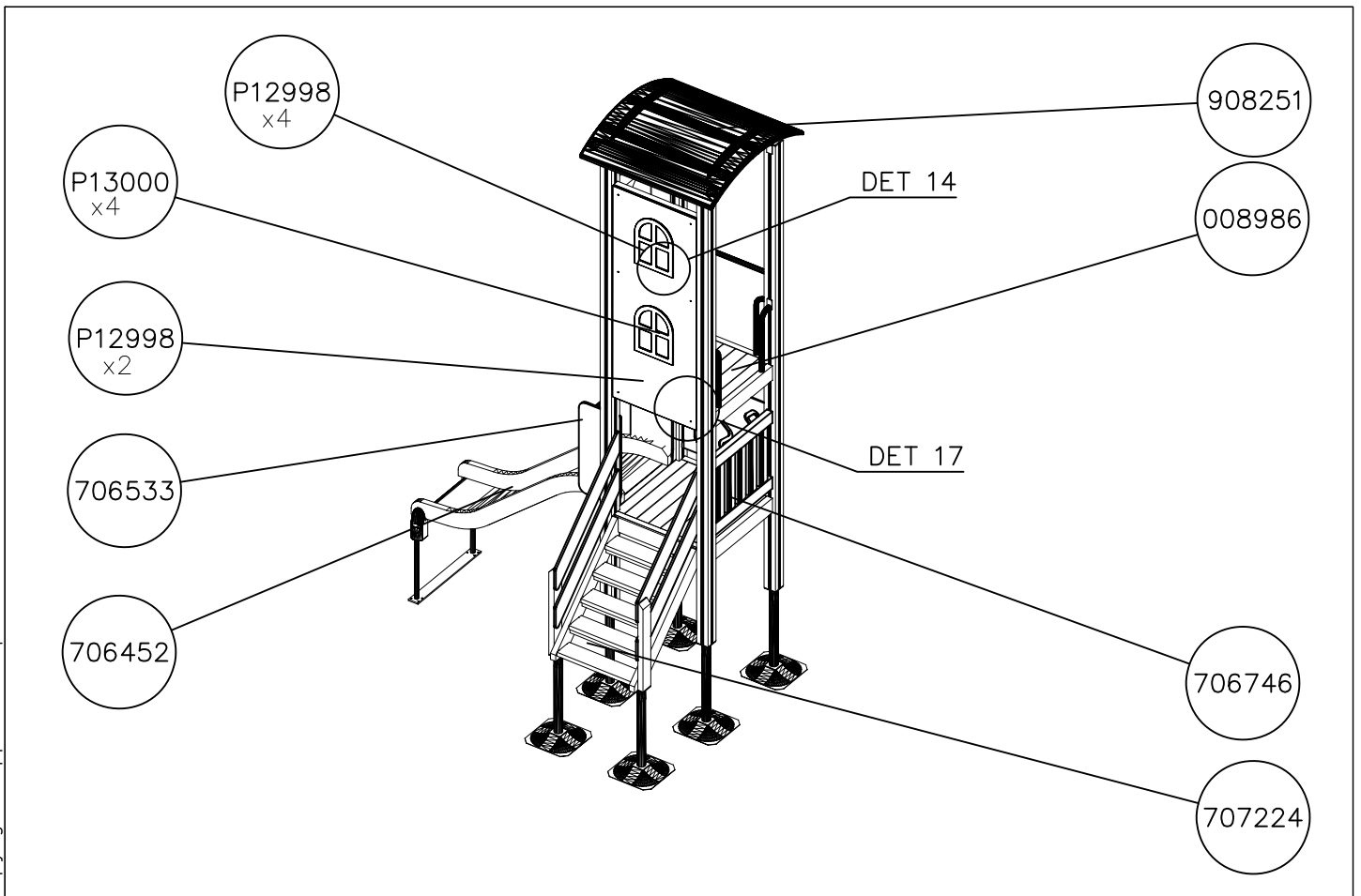
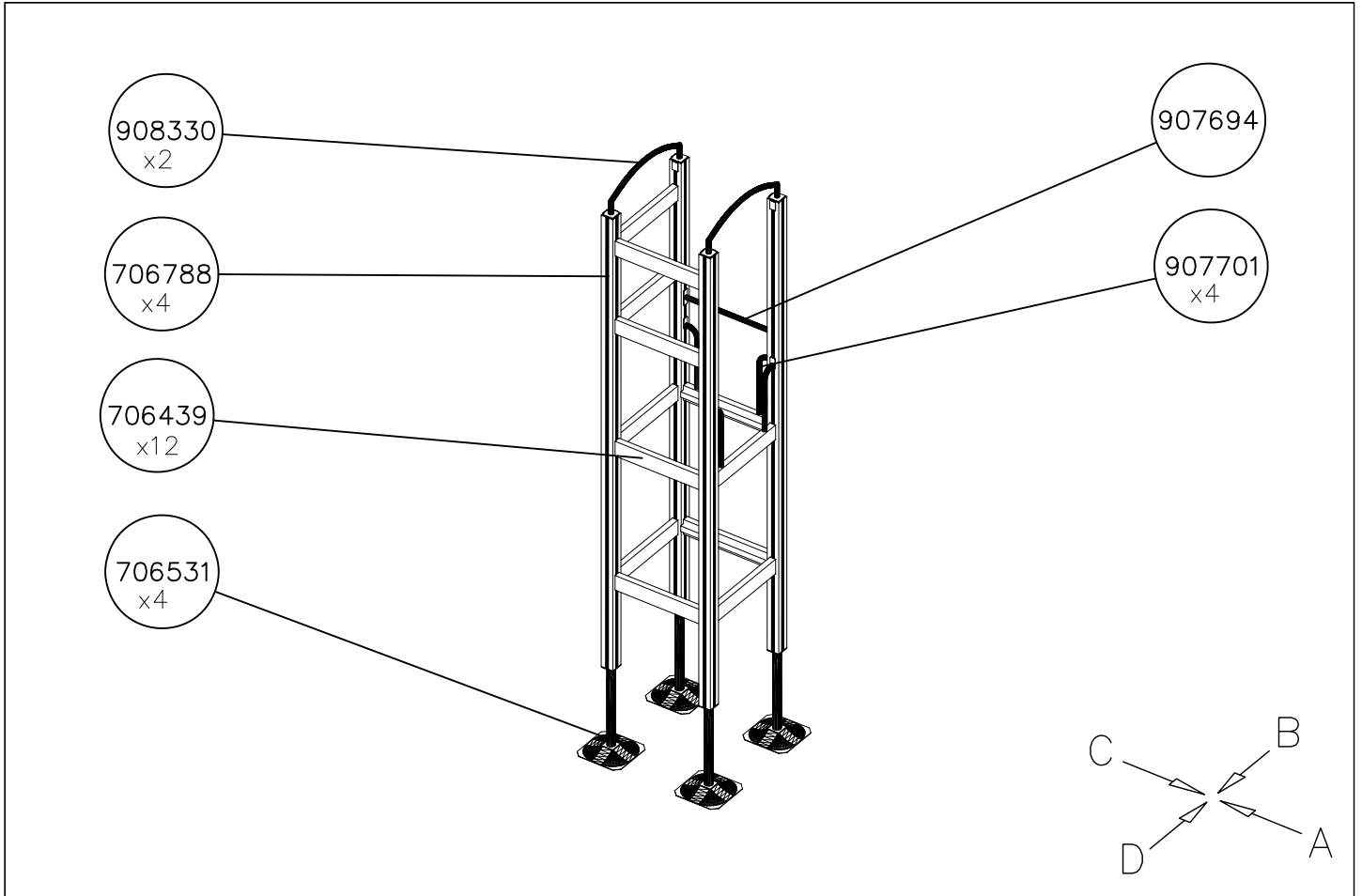

DATE: 25.10.2018

1:50

(A)

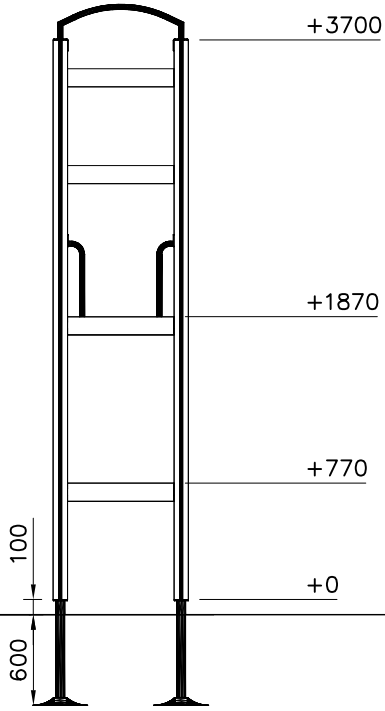

(B)

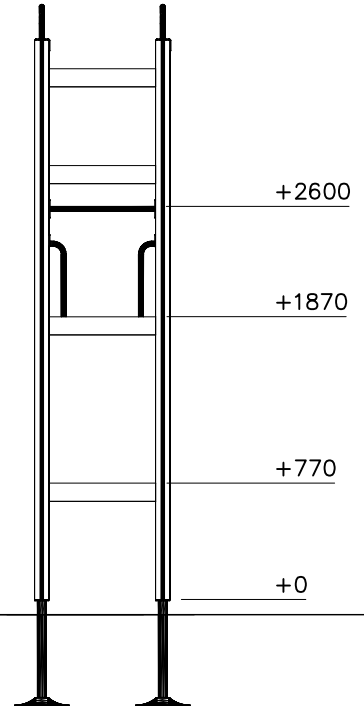

(C)

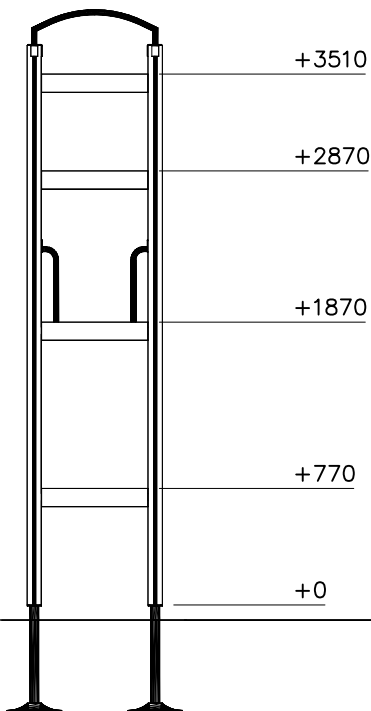

(D)

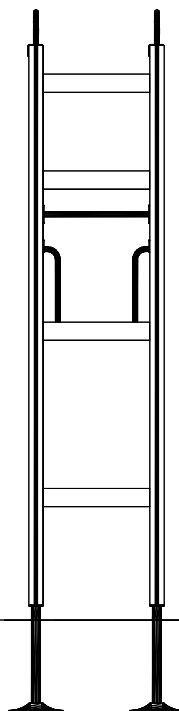

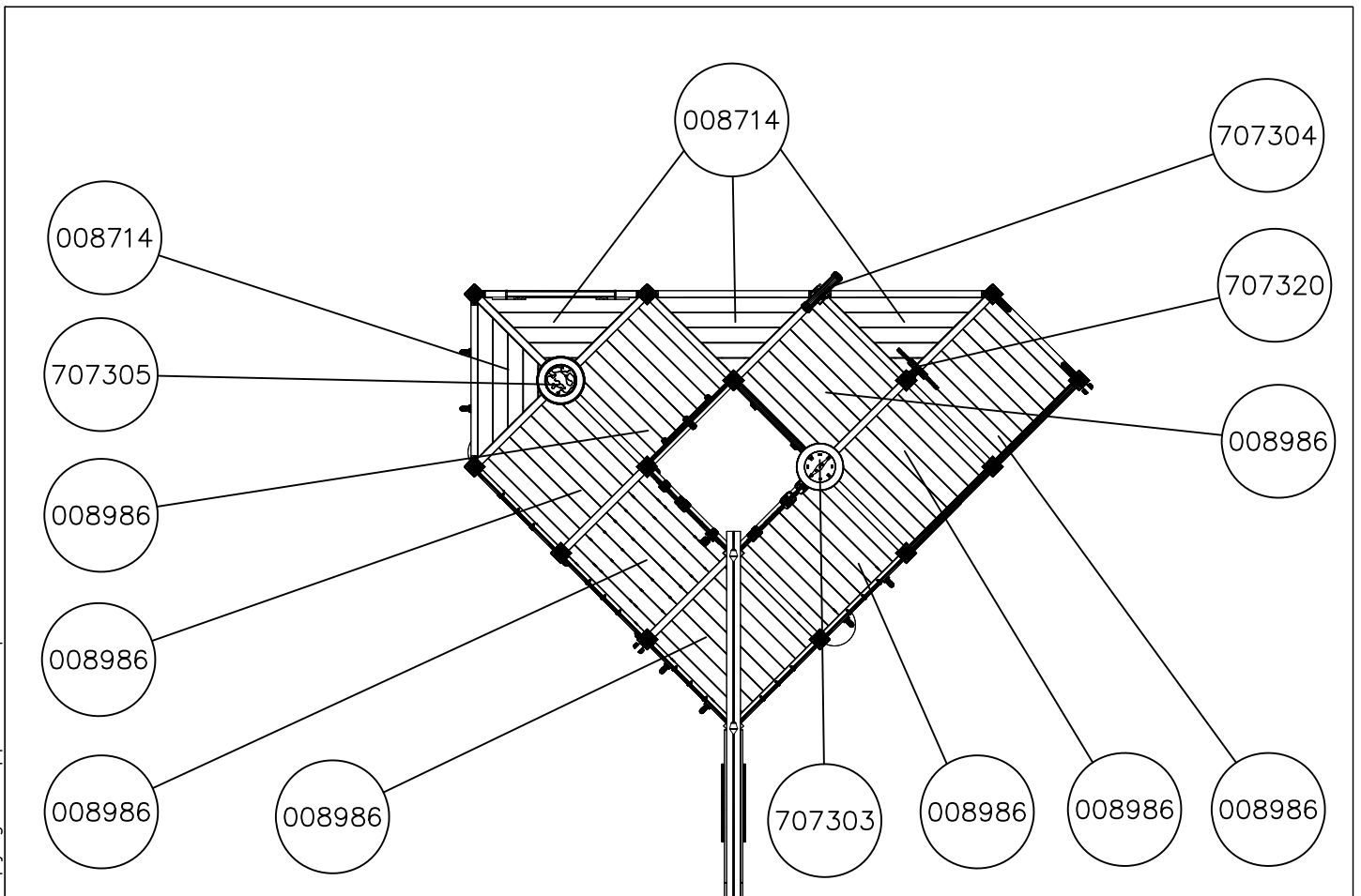
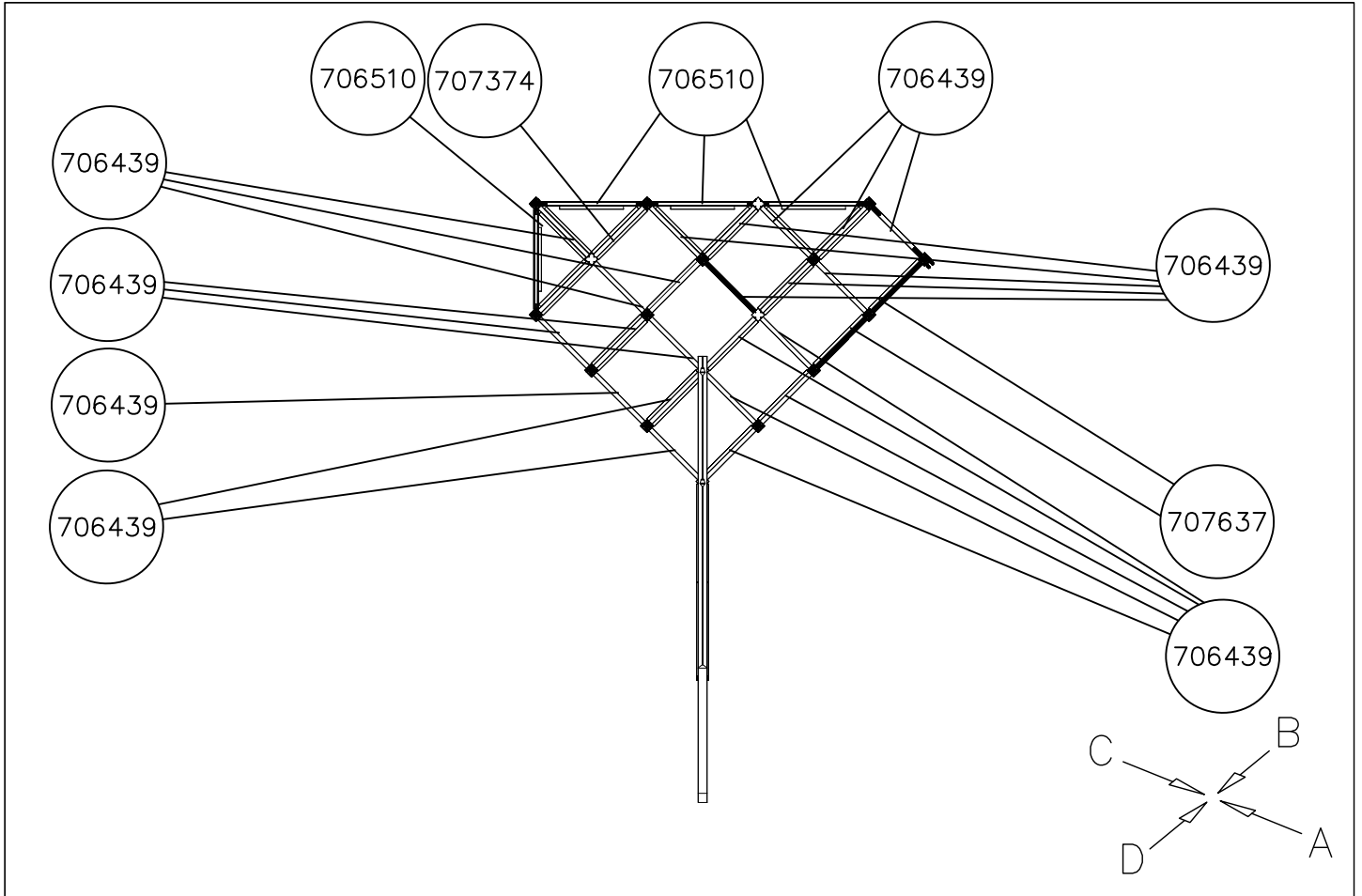

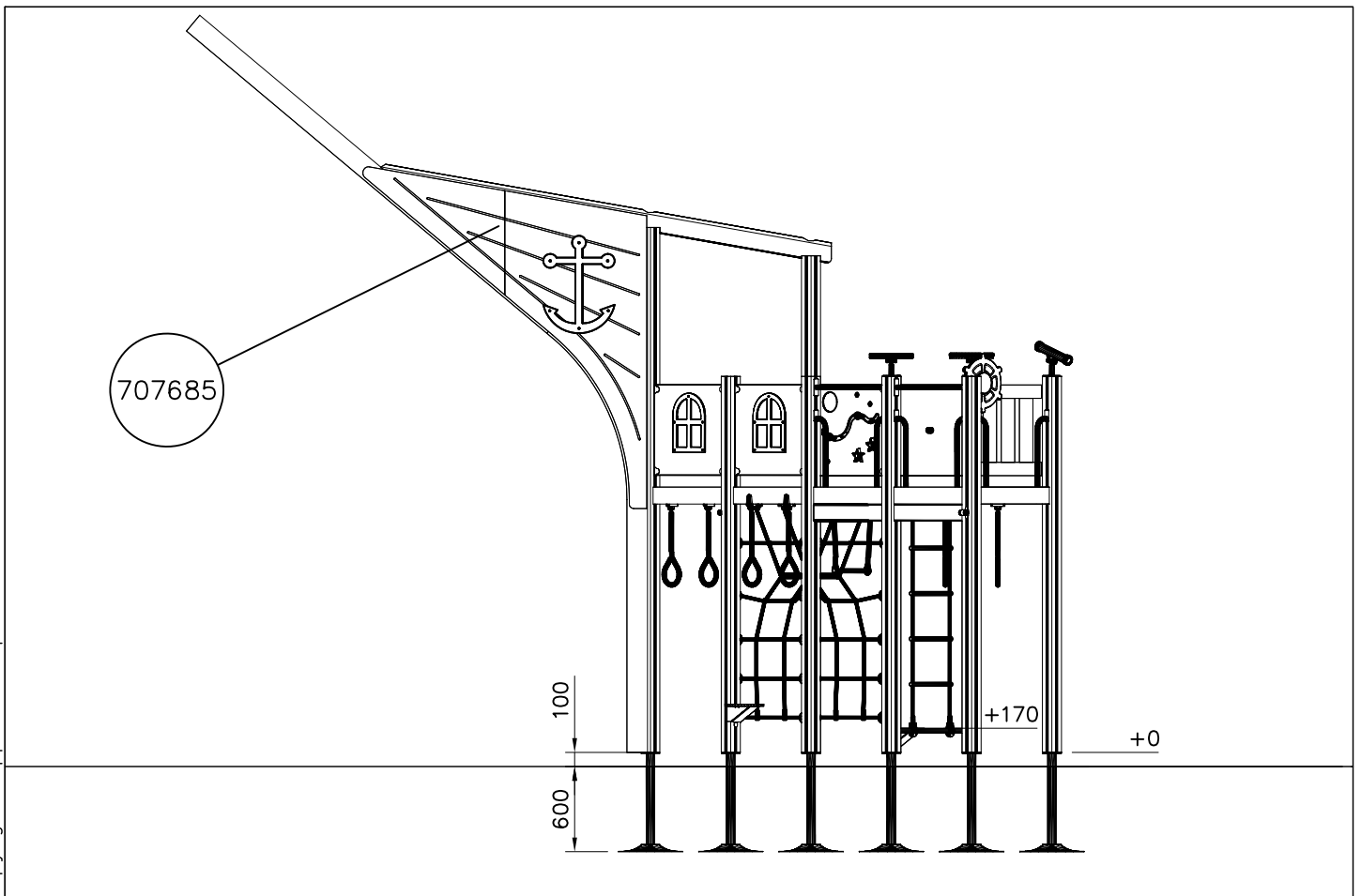
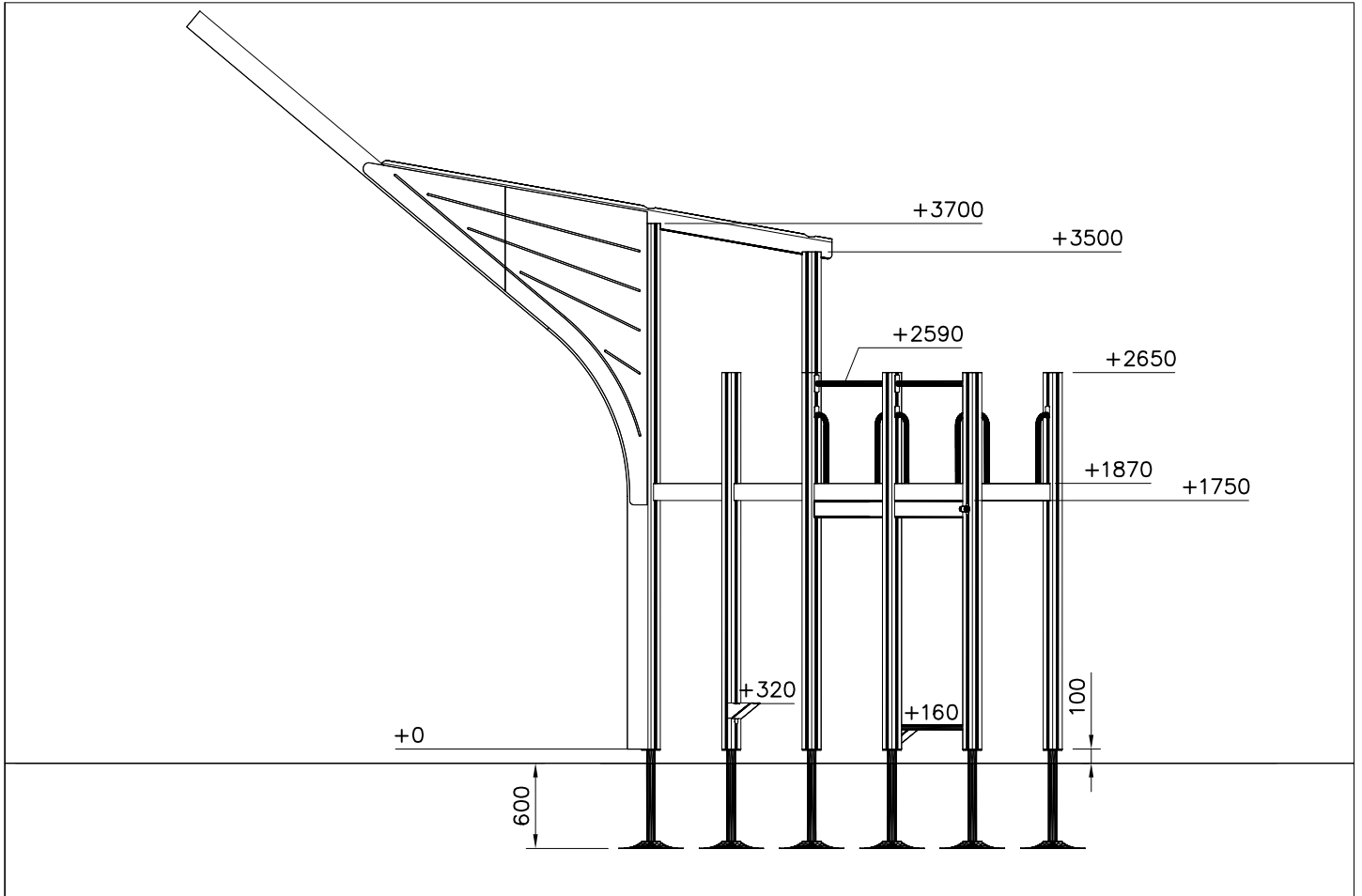

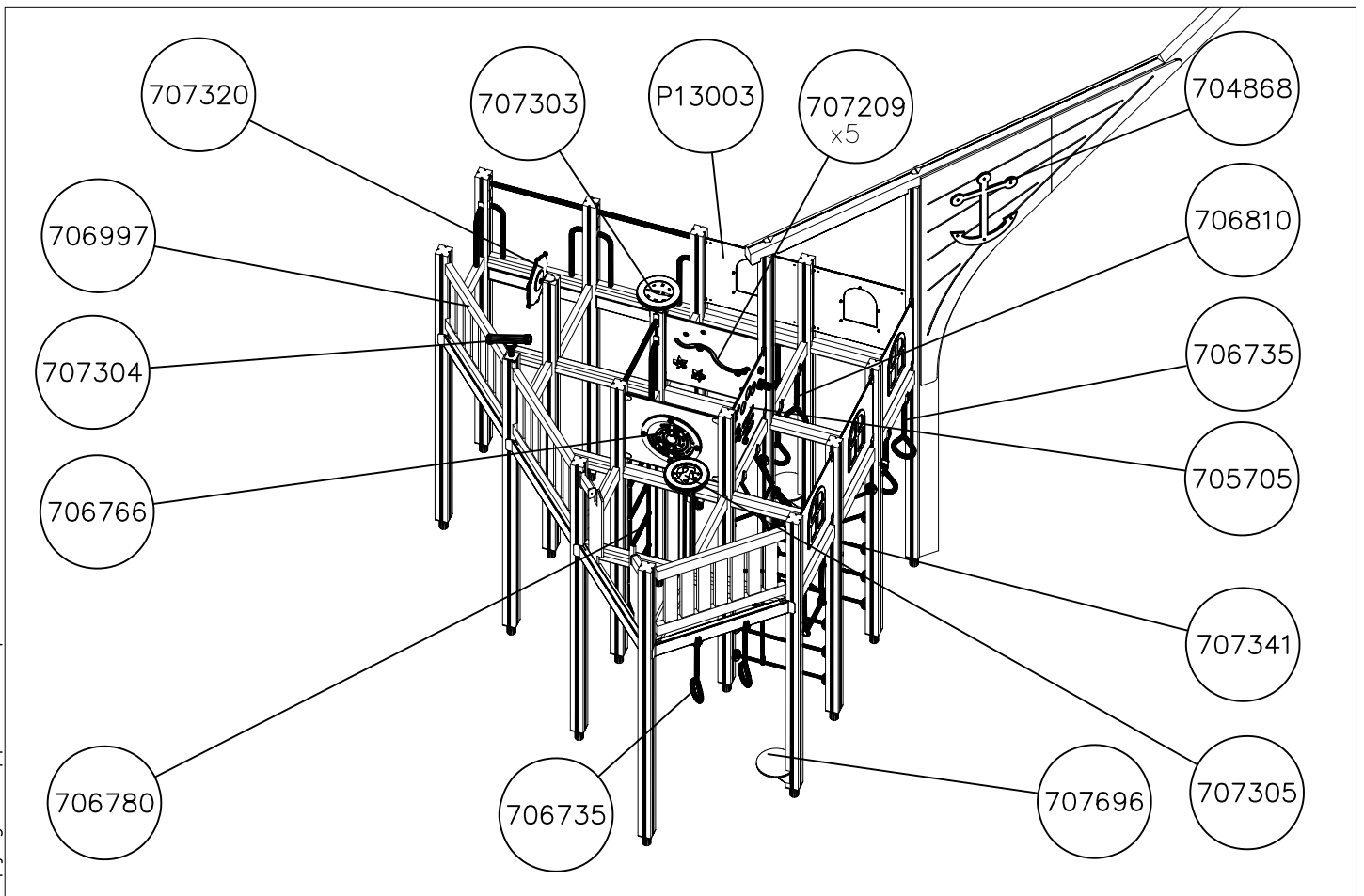
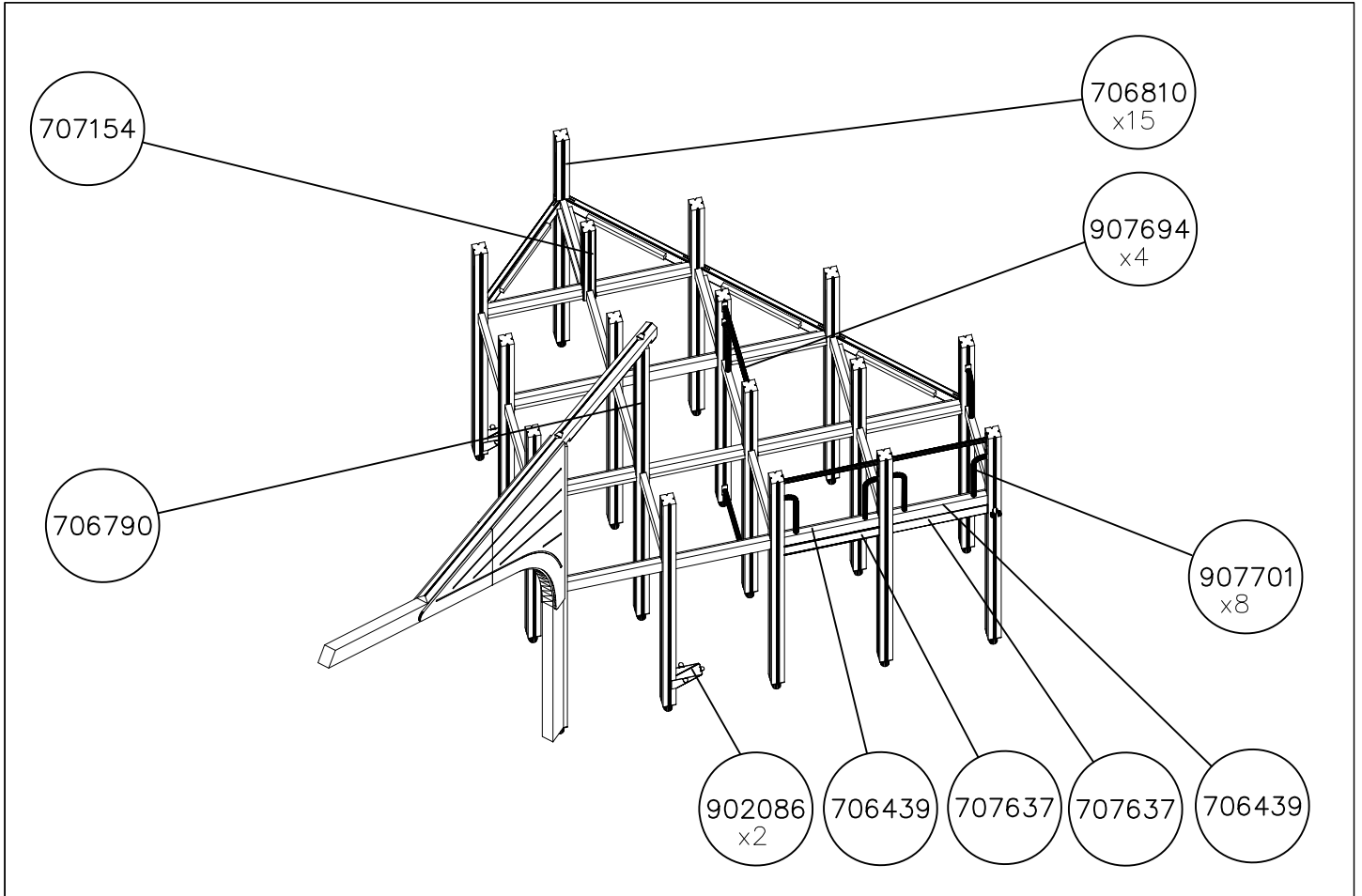

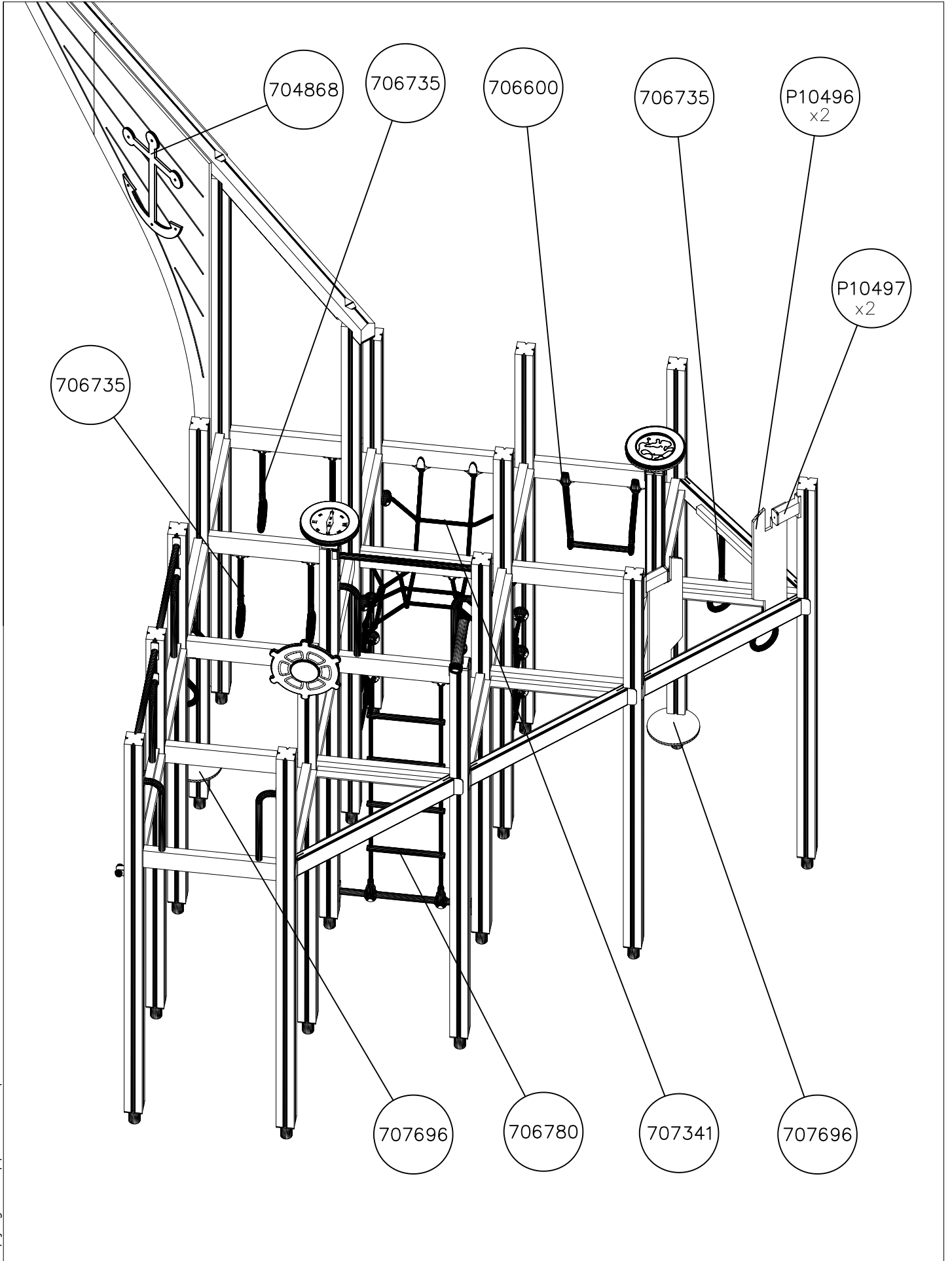

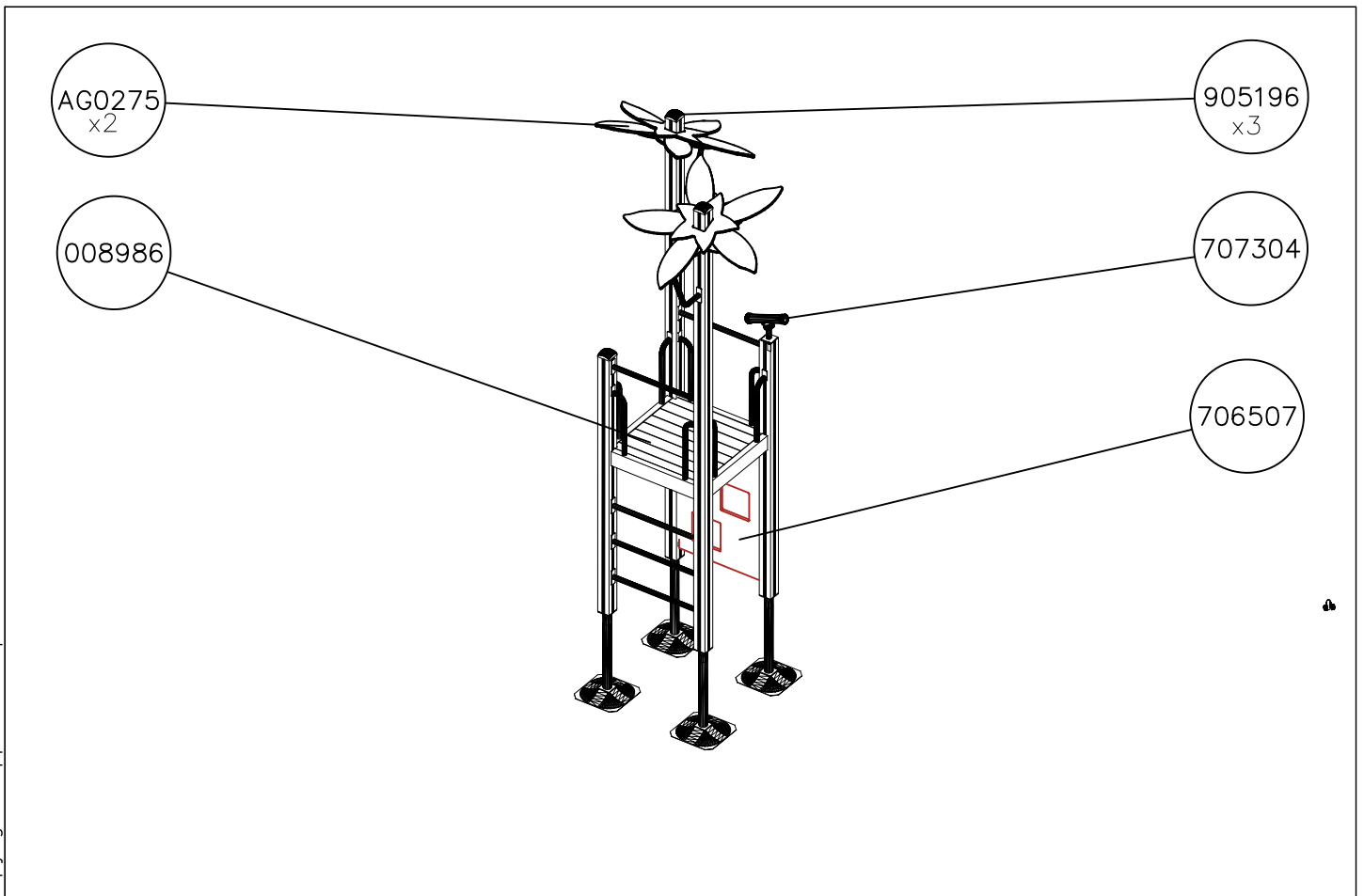
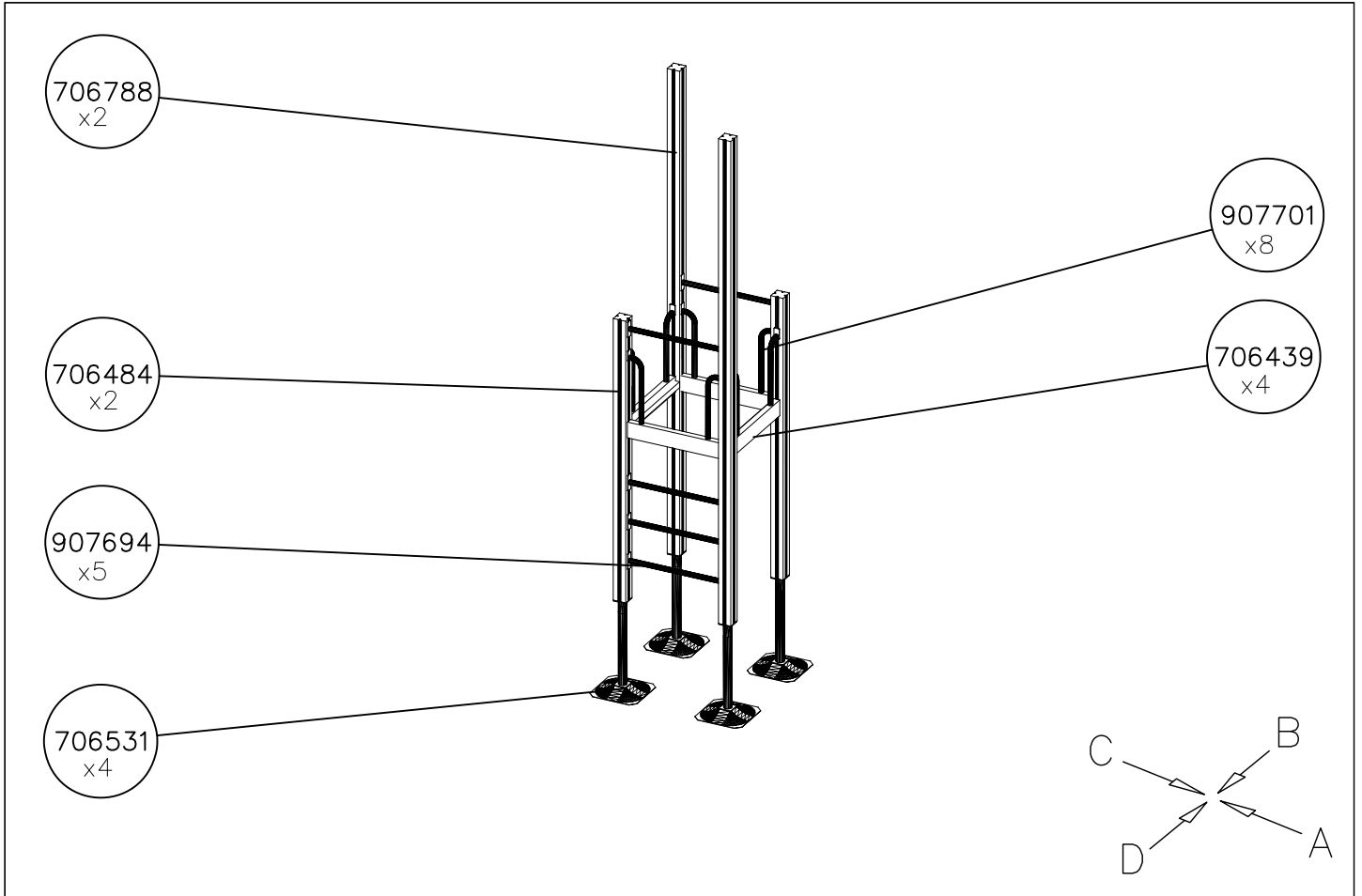

DATE: 25.10.2018

1:50

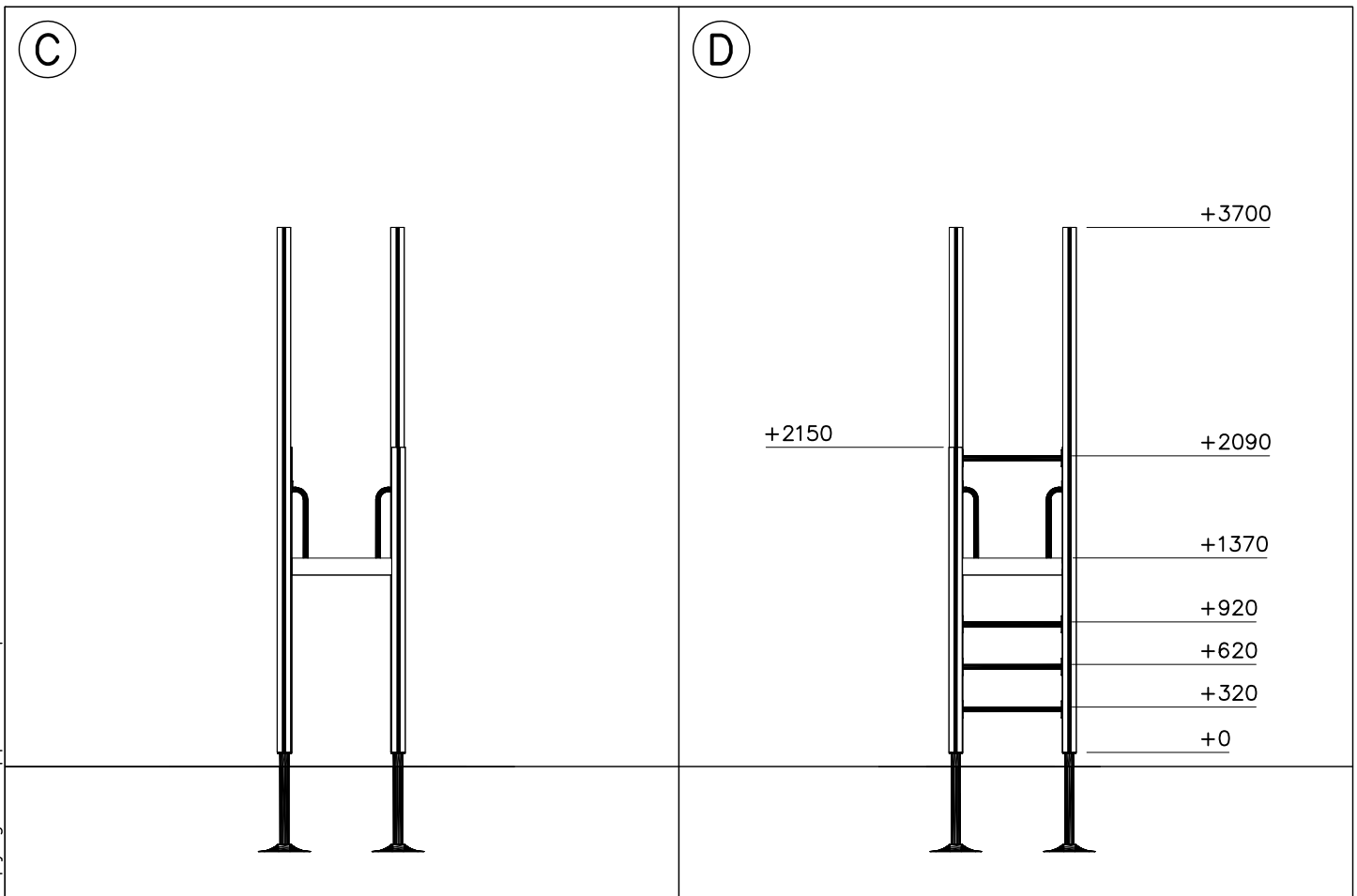
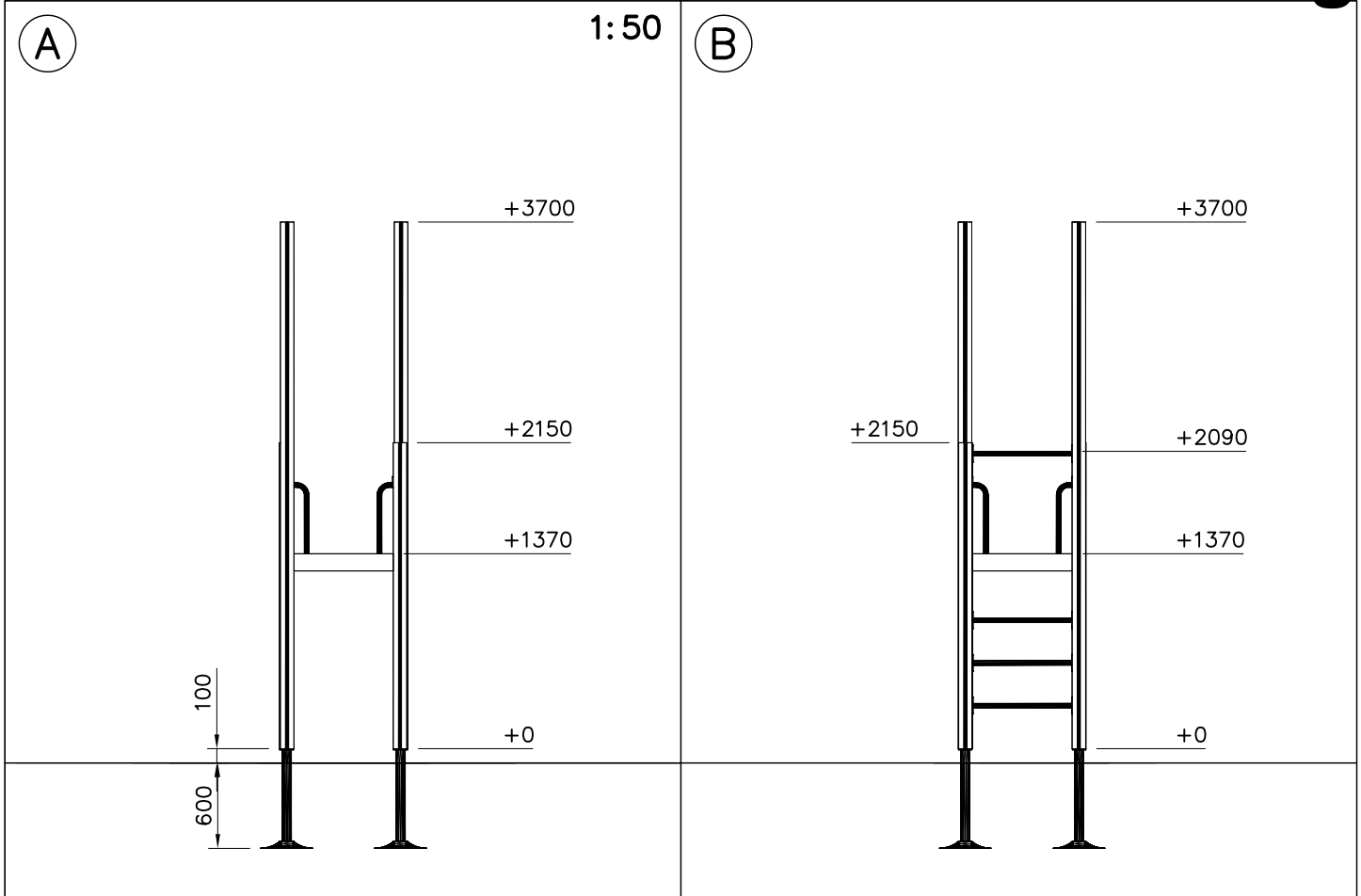

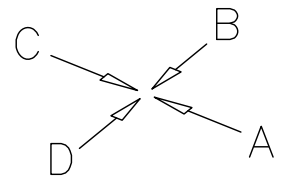
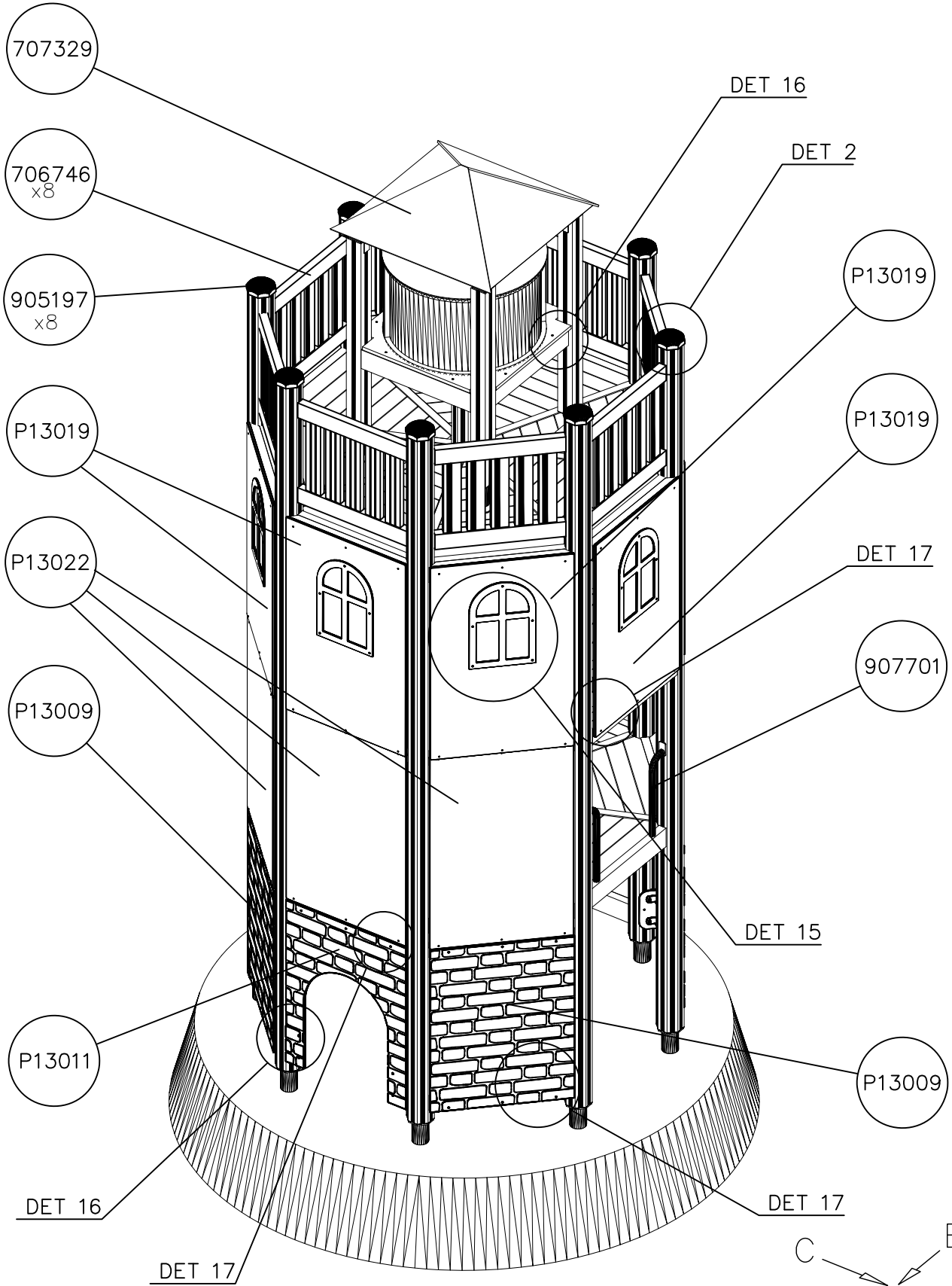

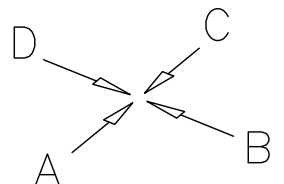
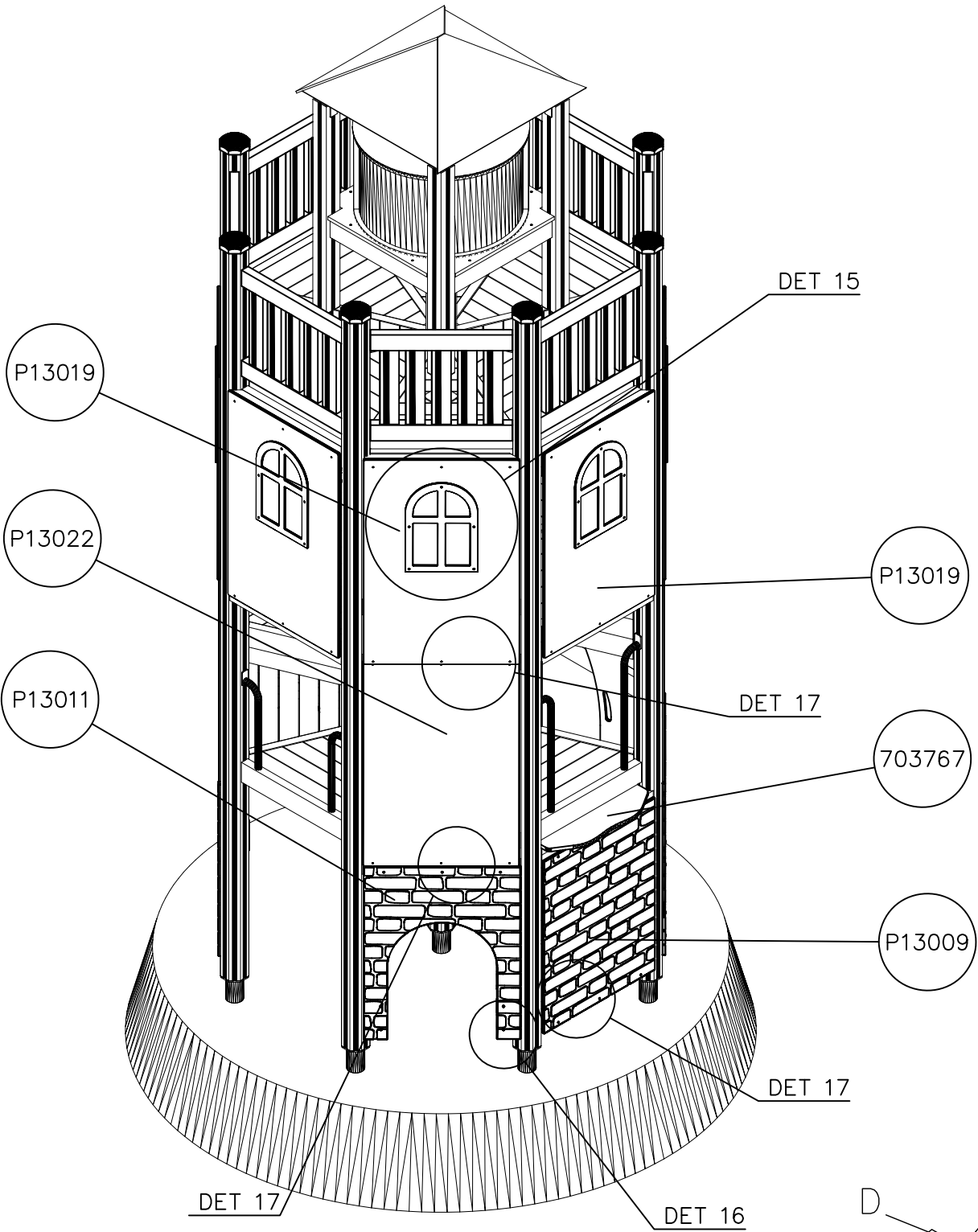

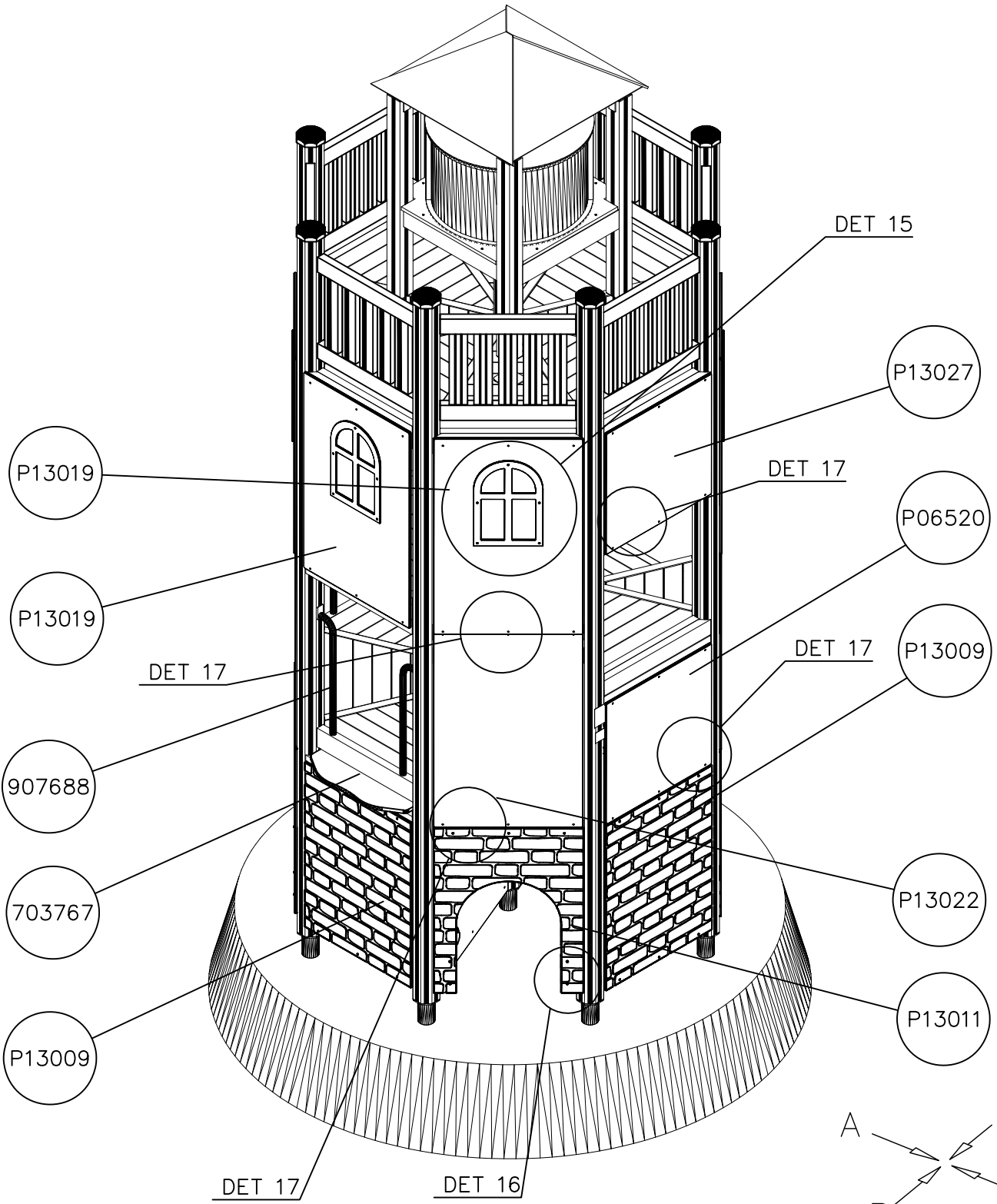

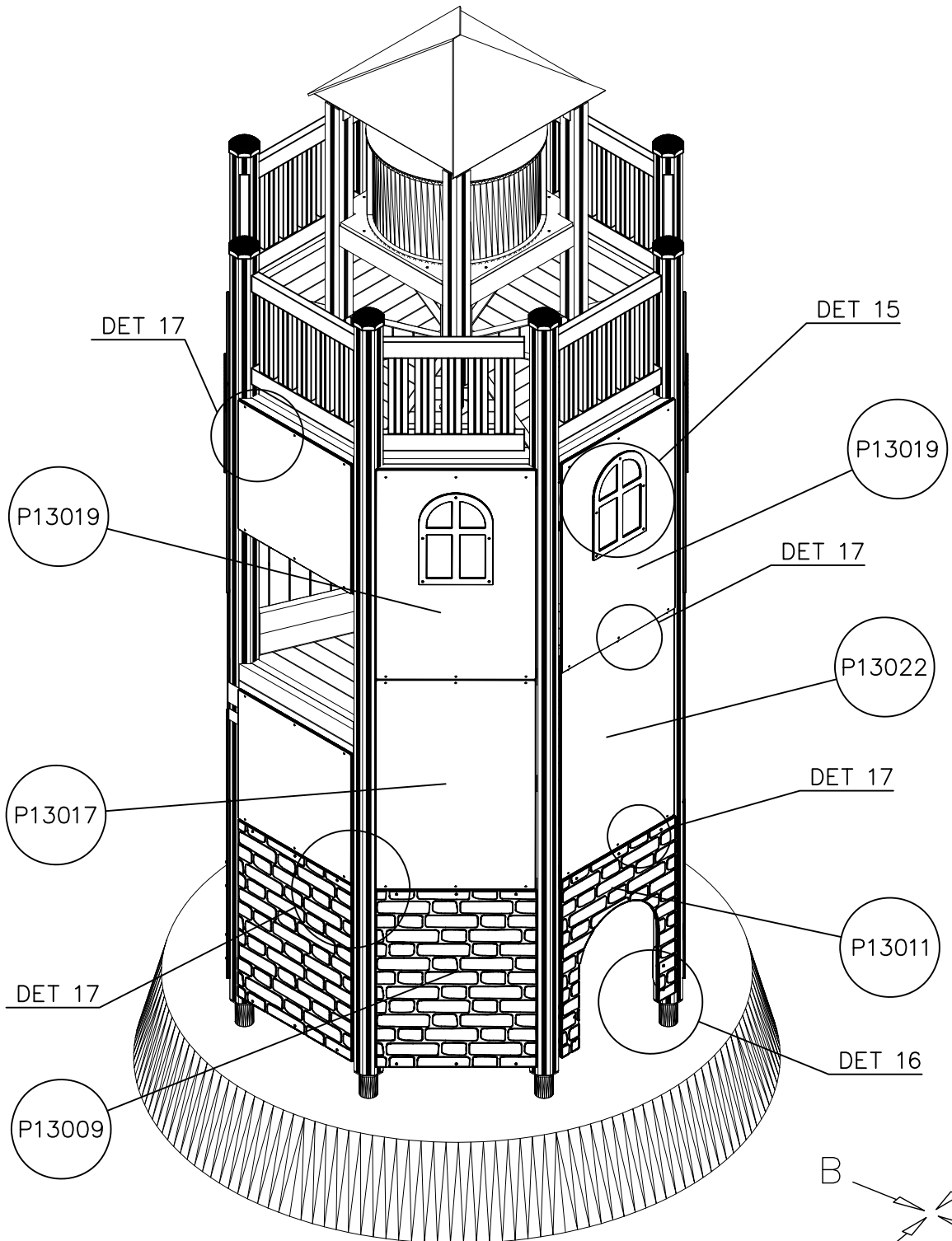

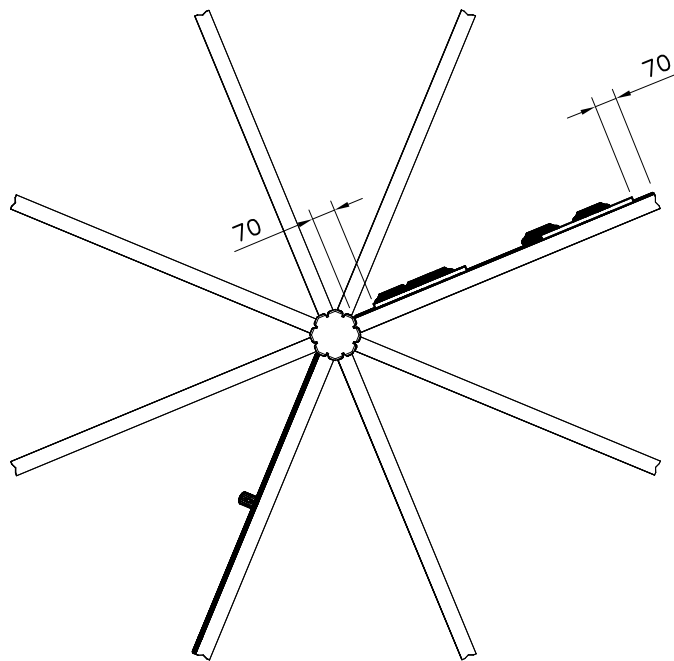
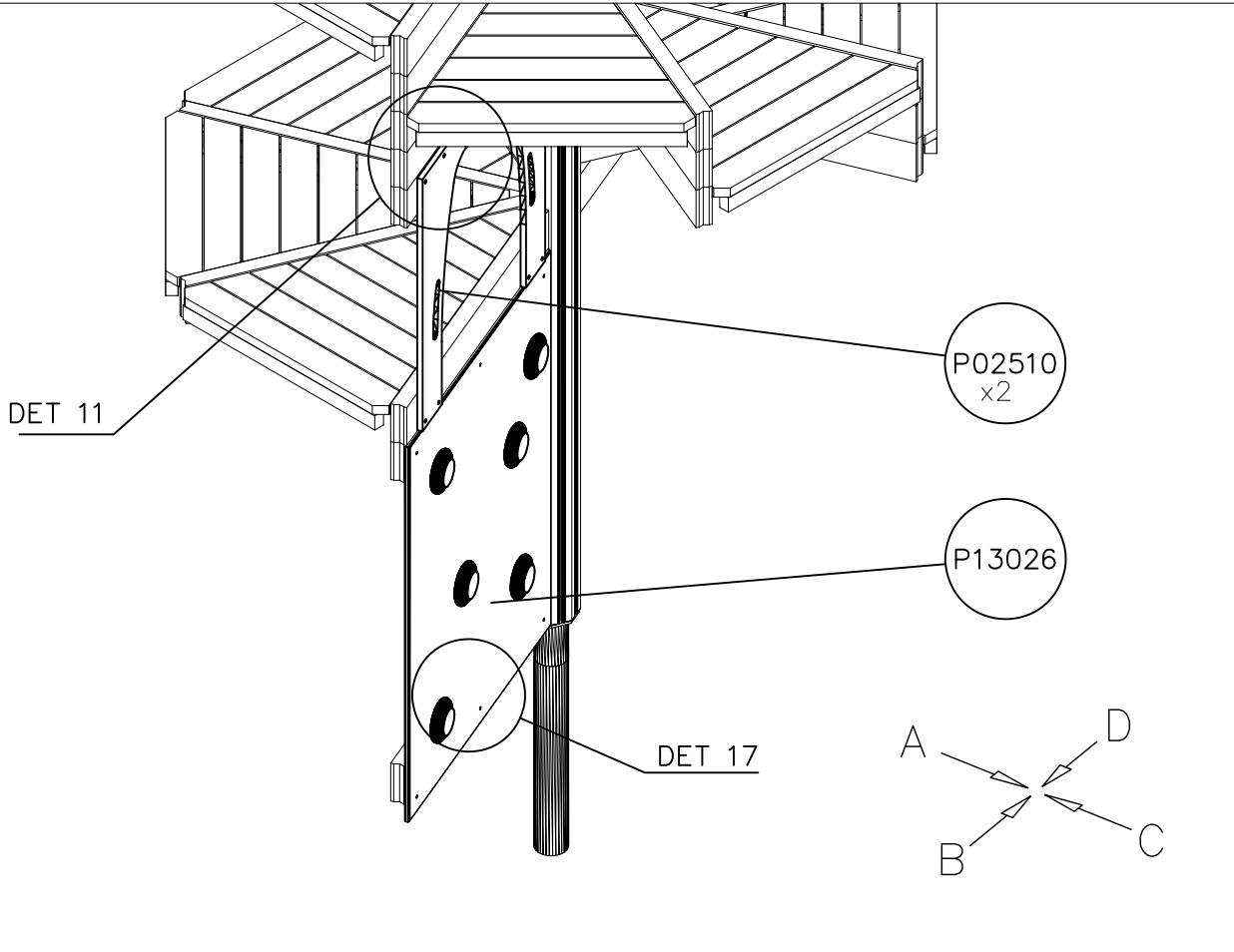

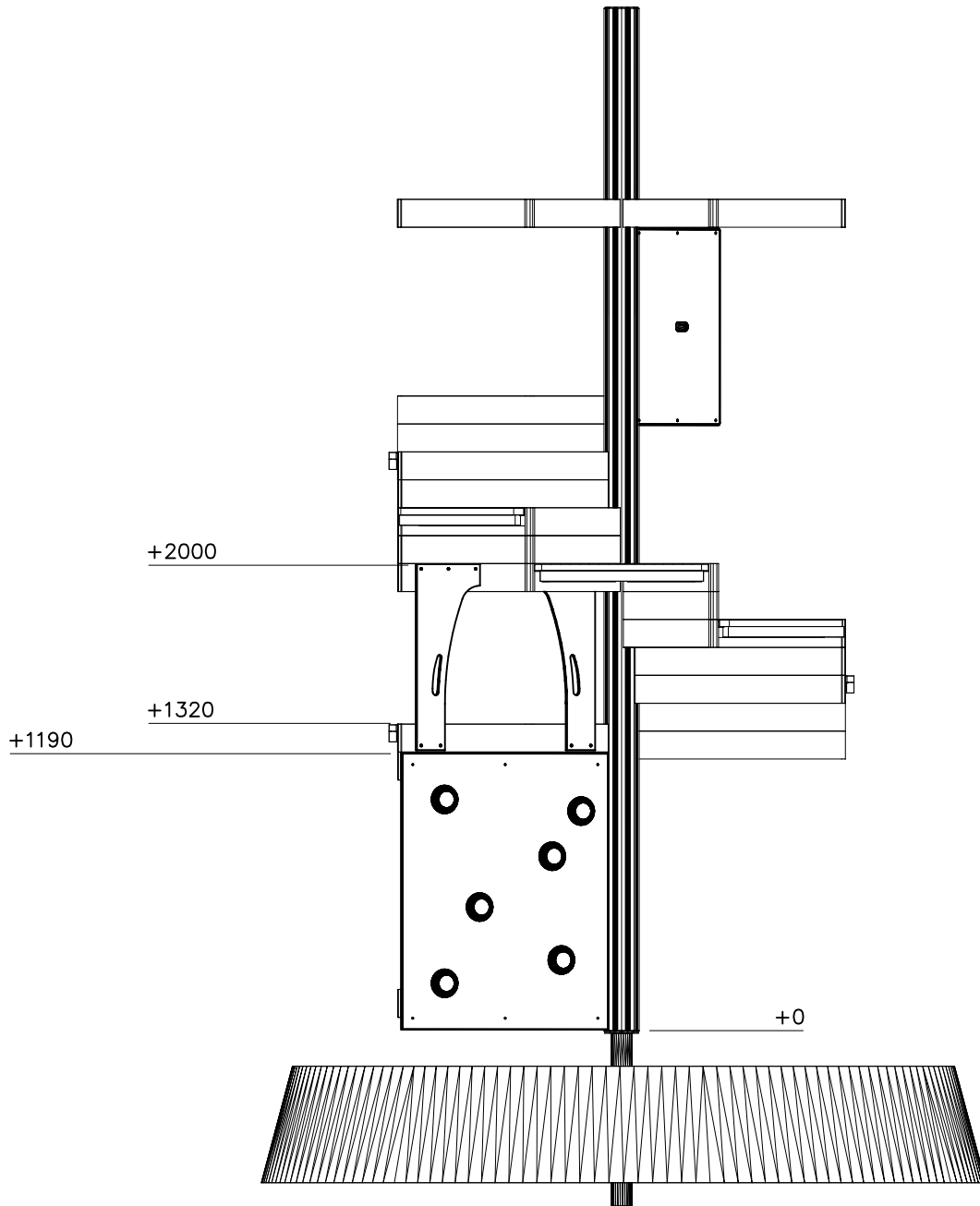

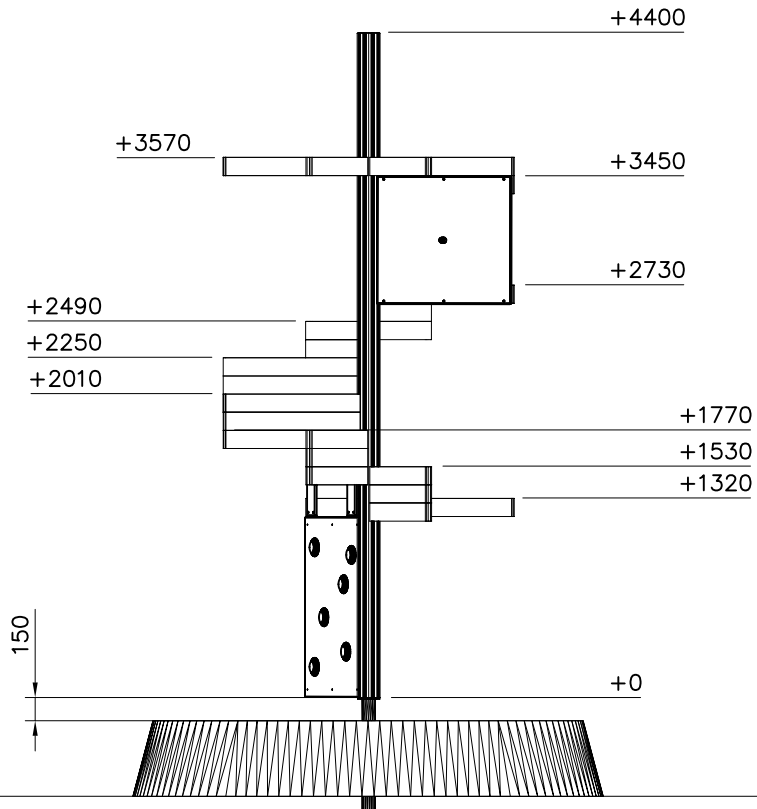
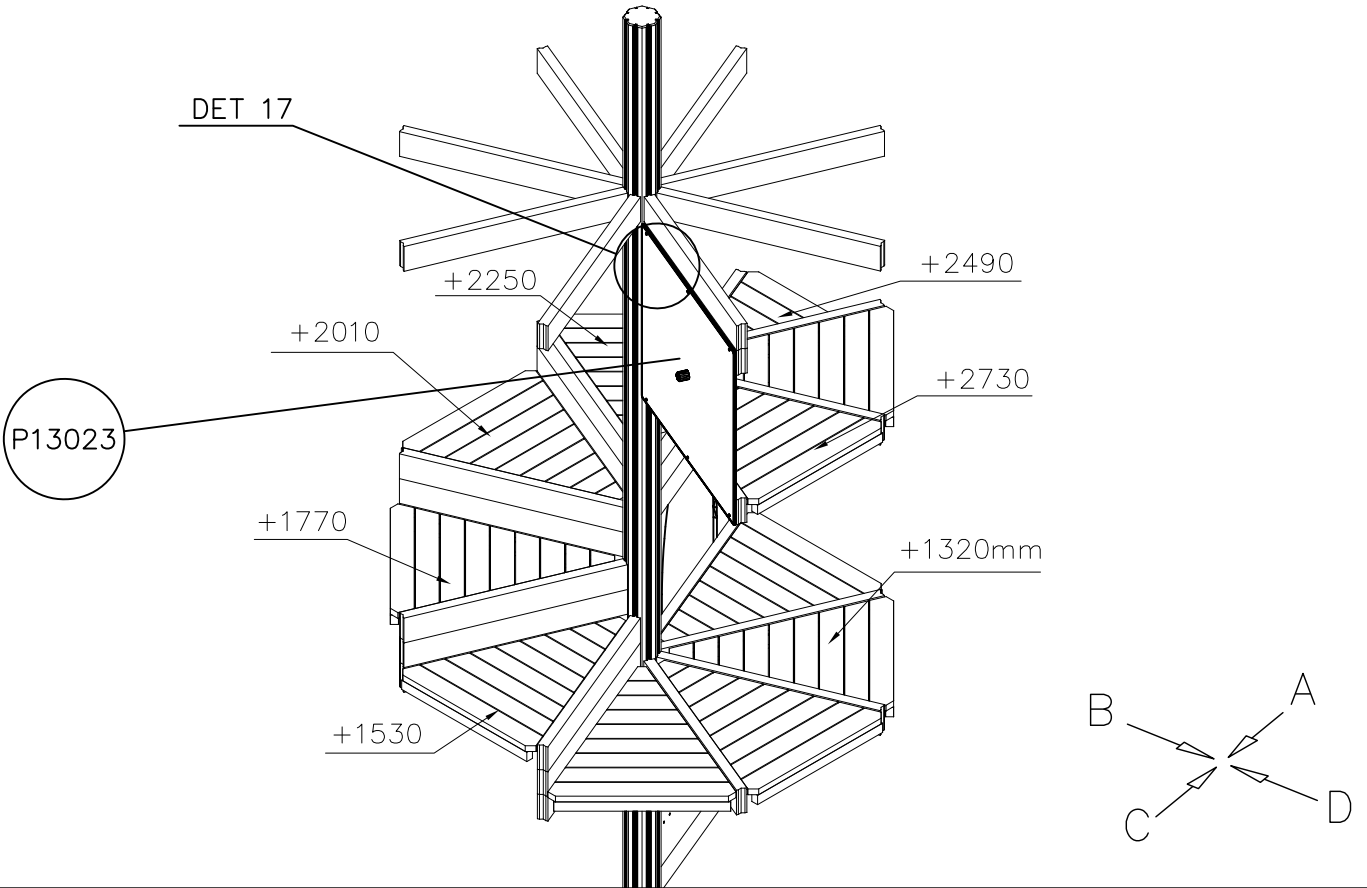

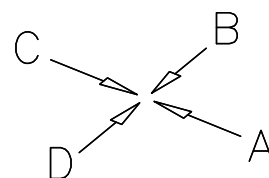
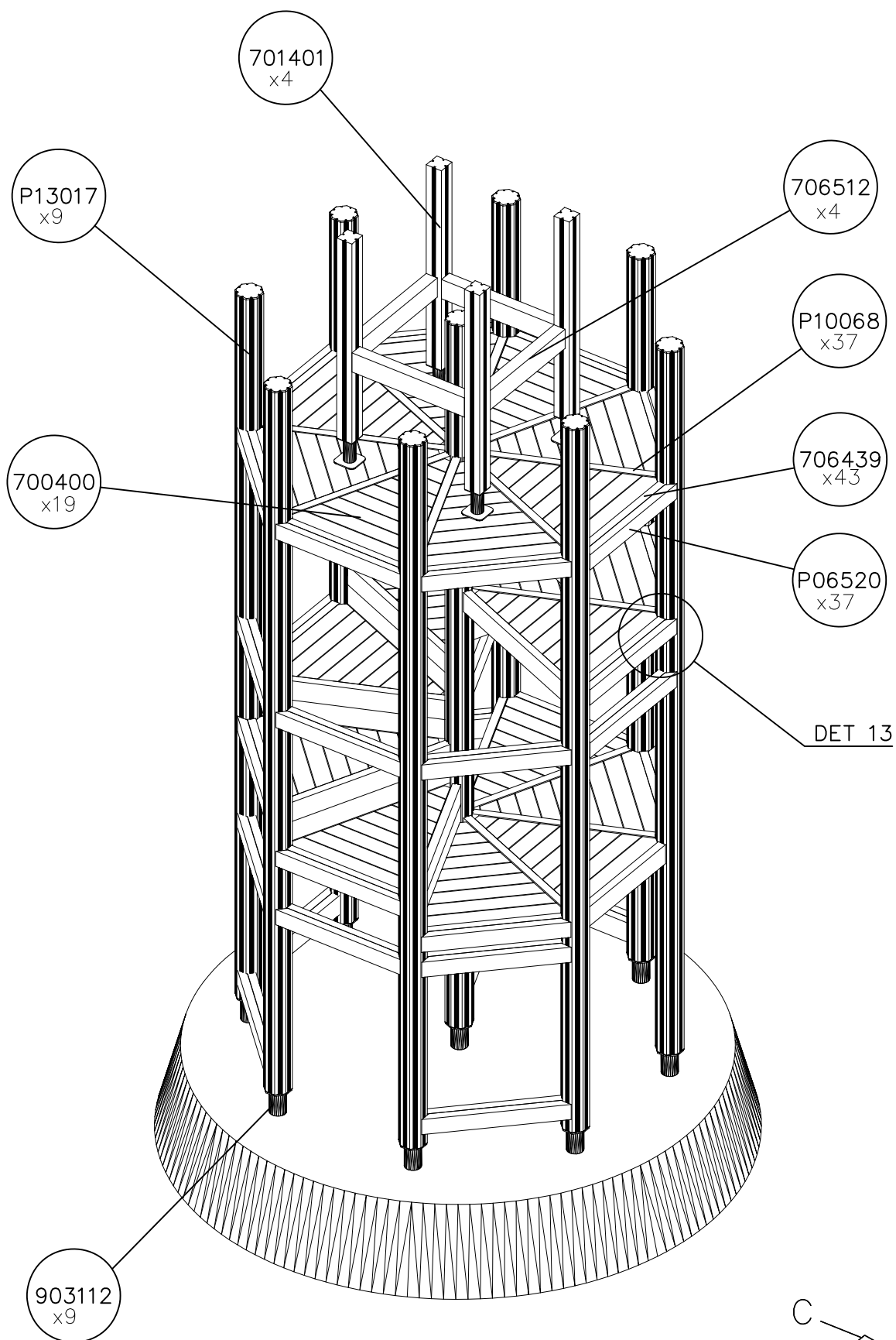

A

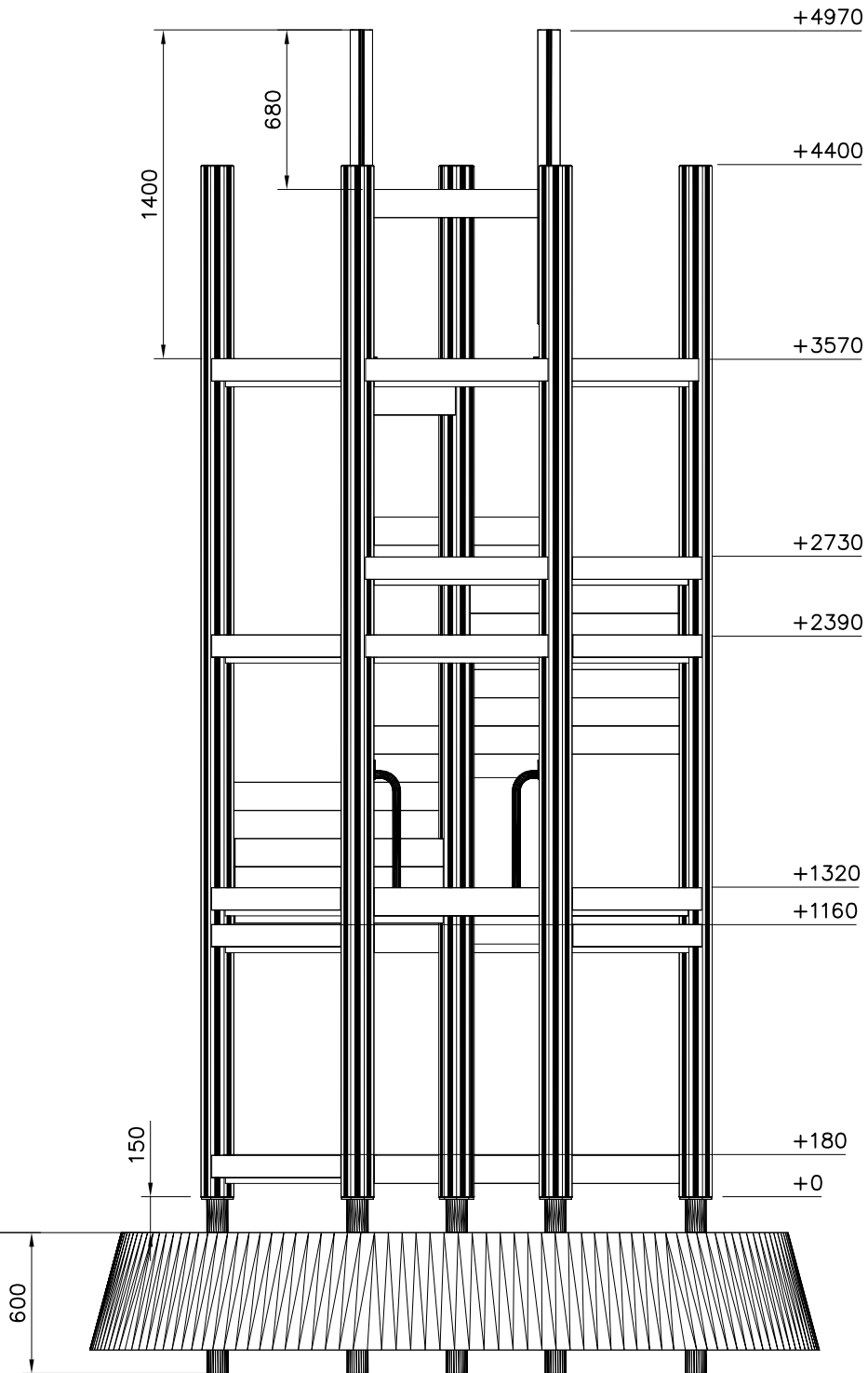

(B)

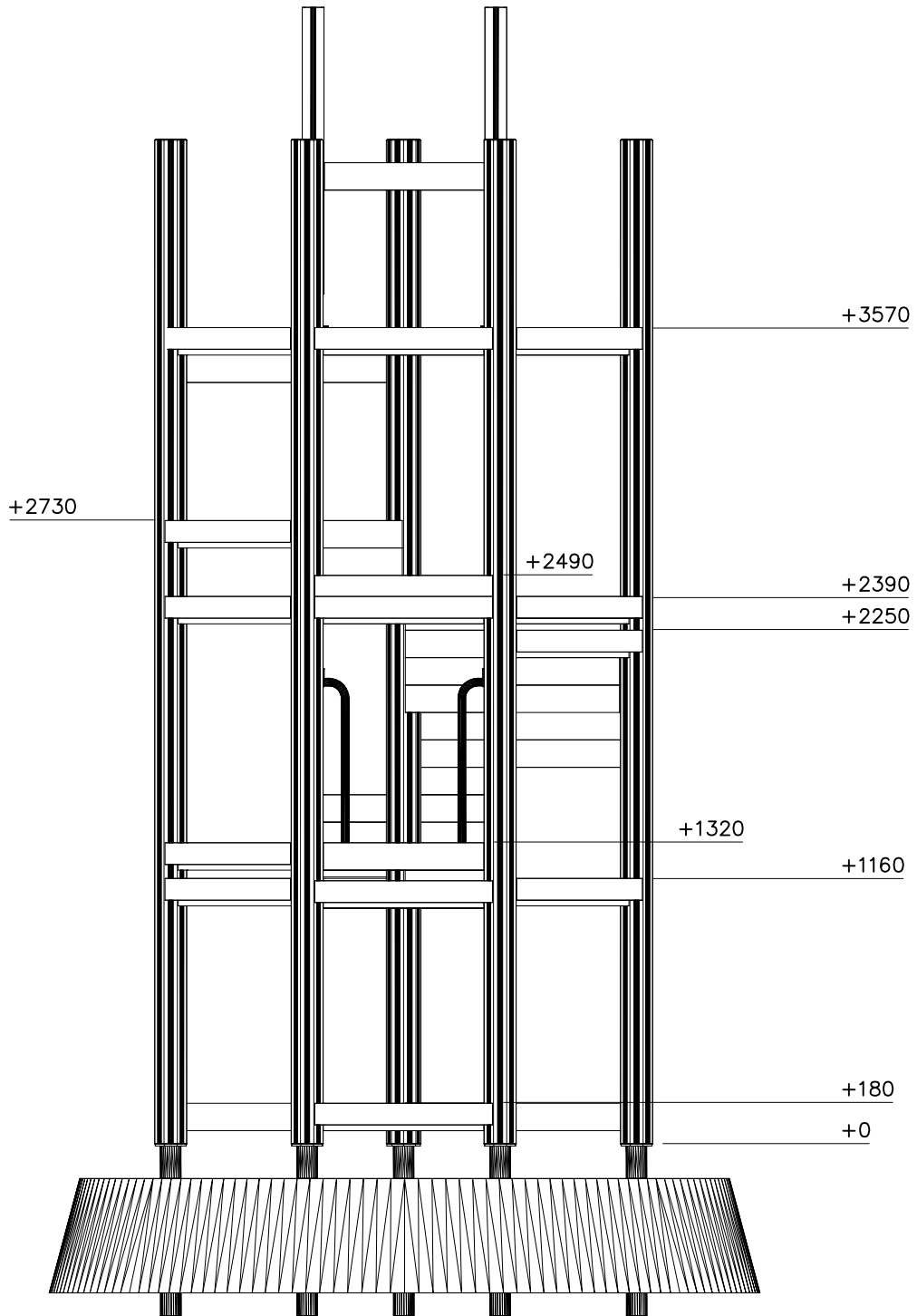

(C)

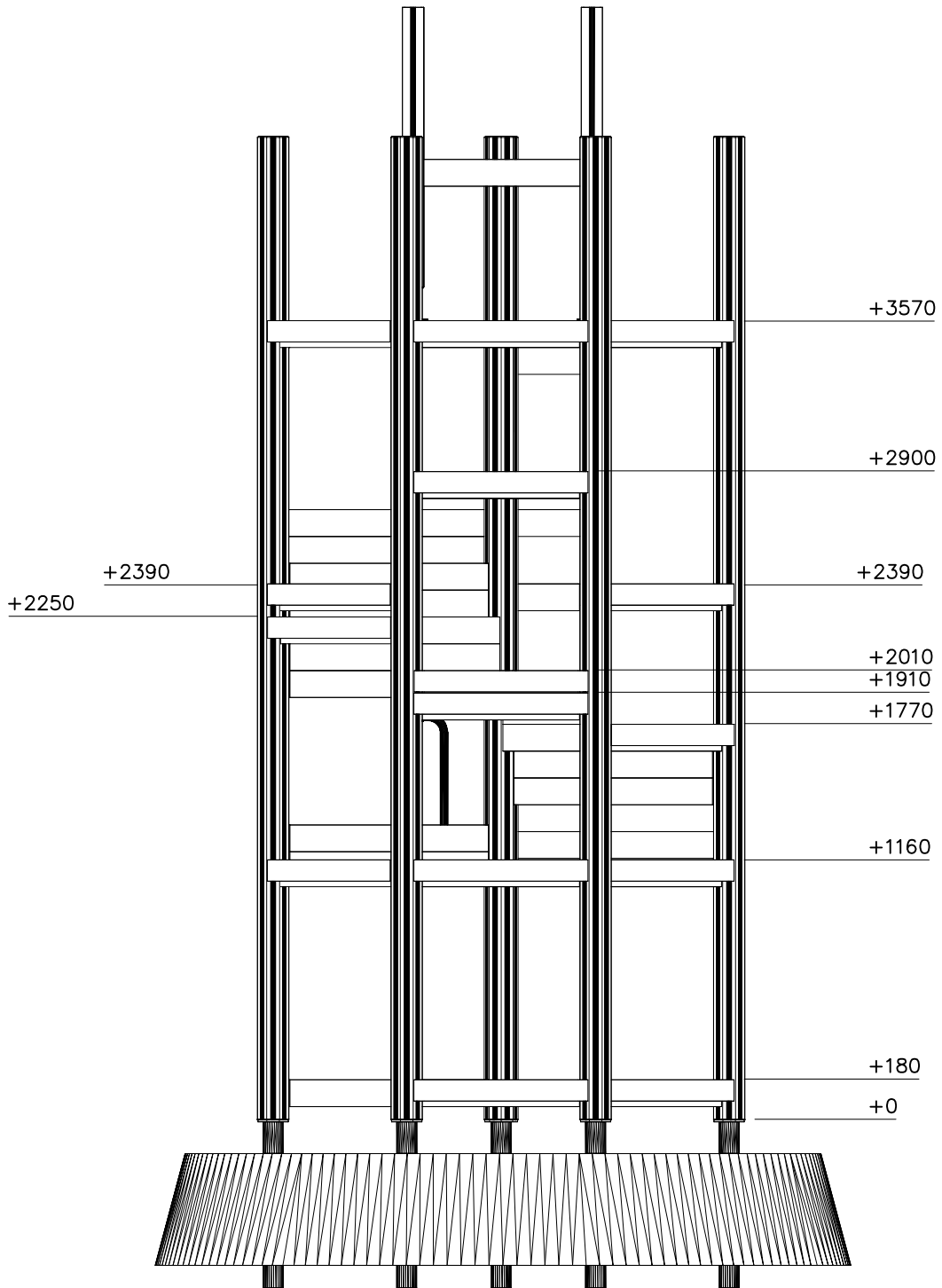

(D)

1:30

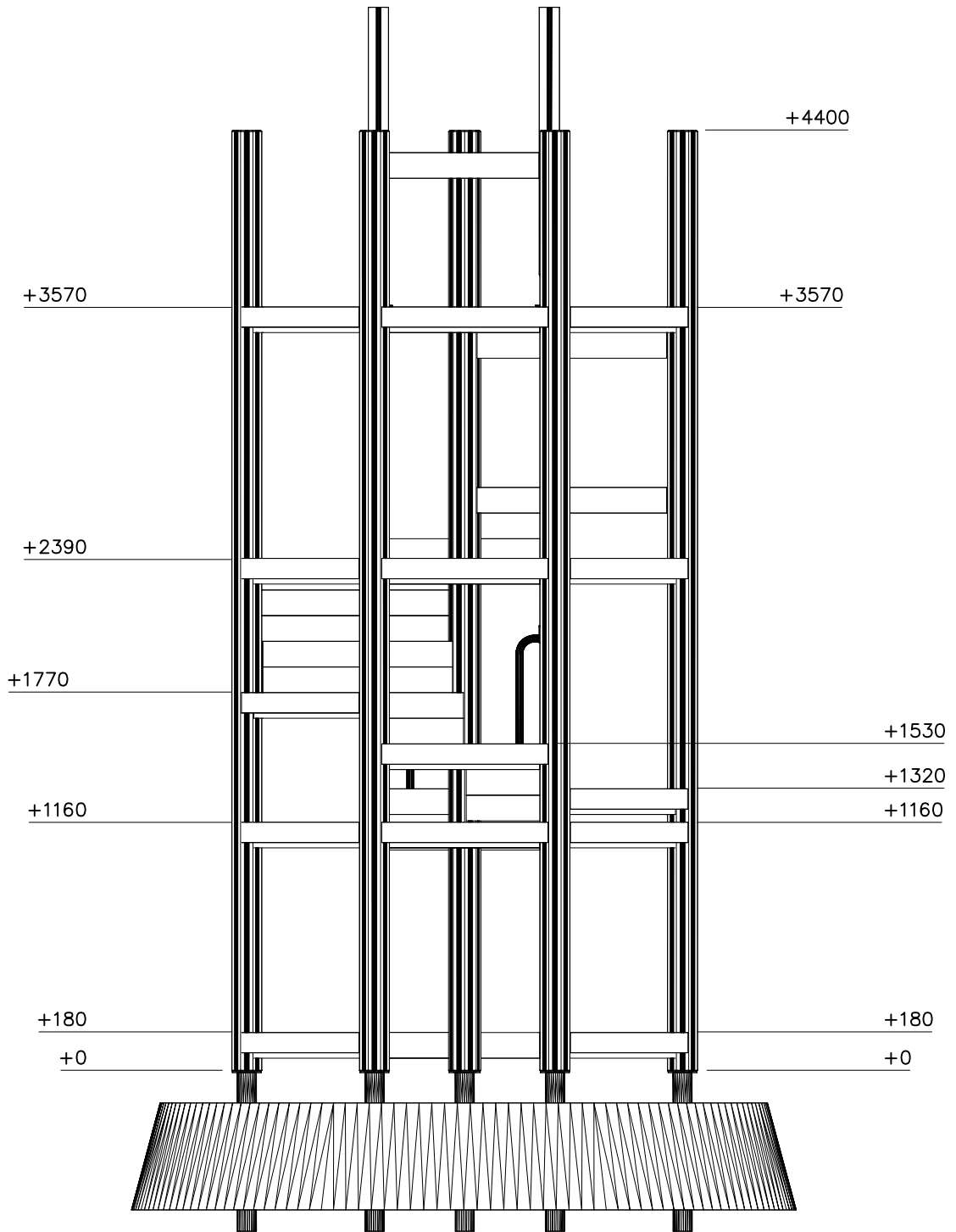

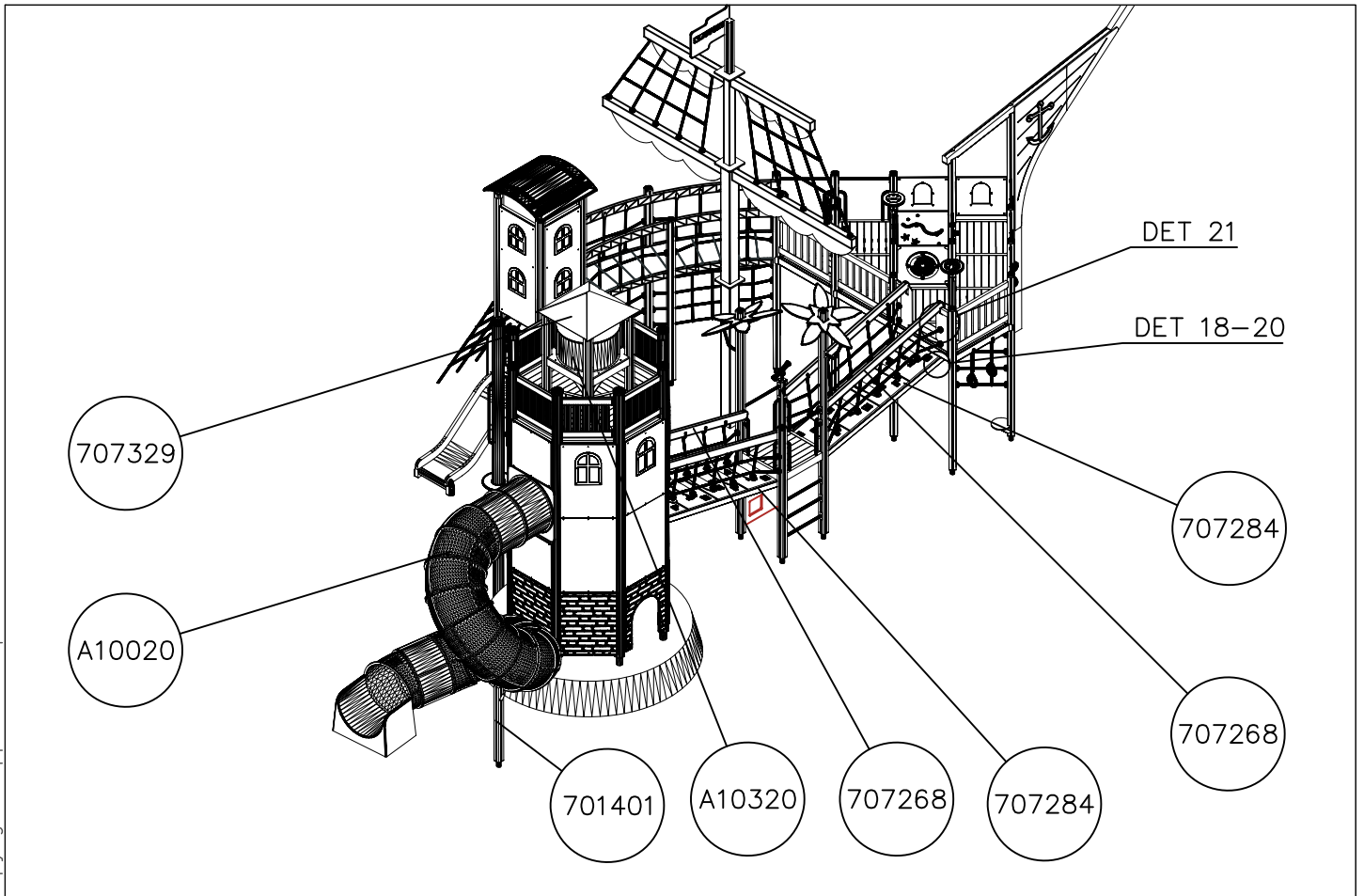
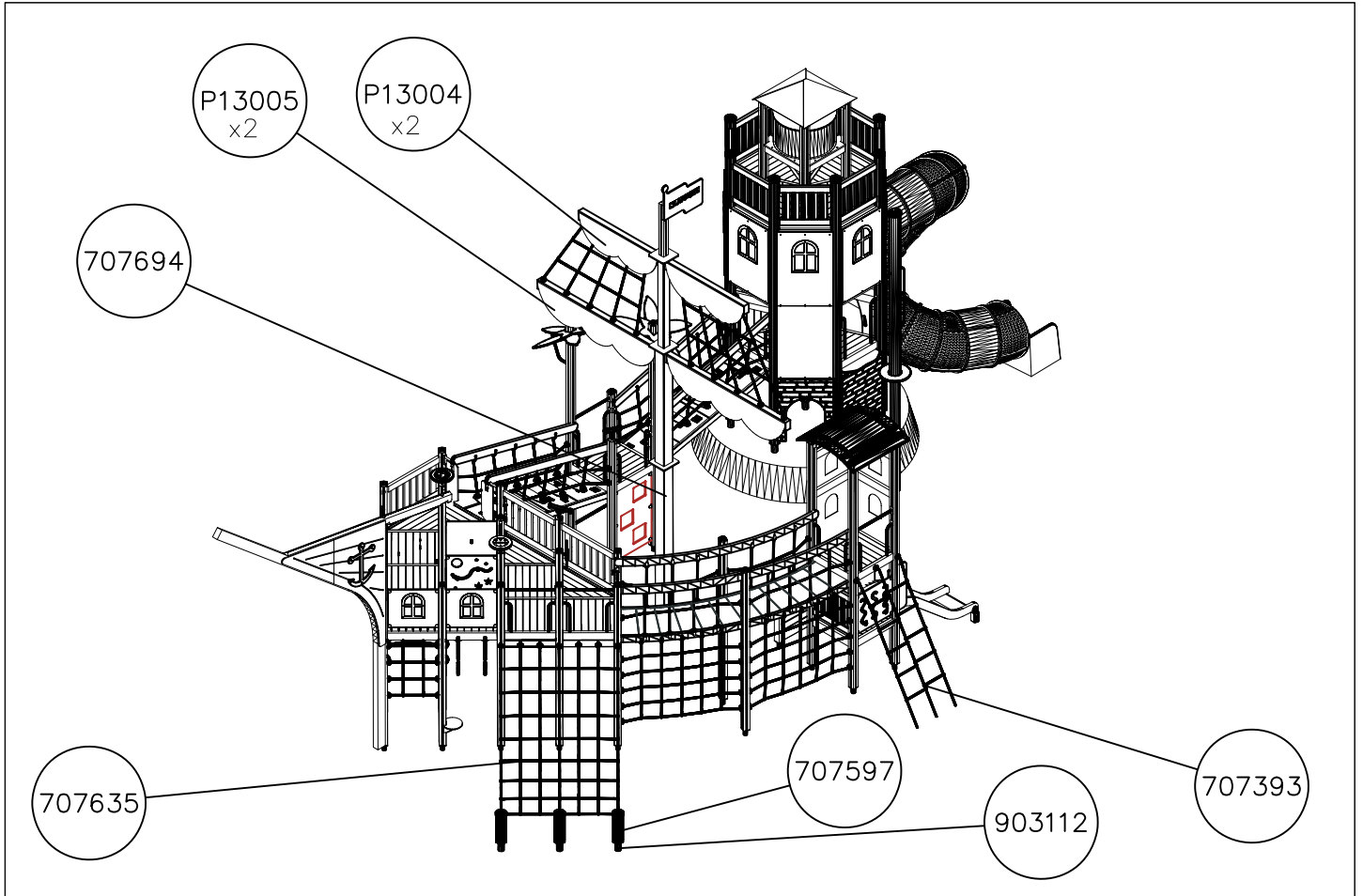

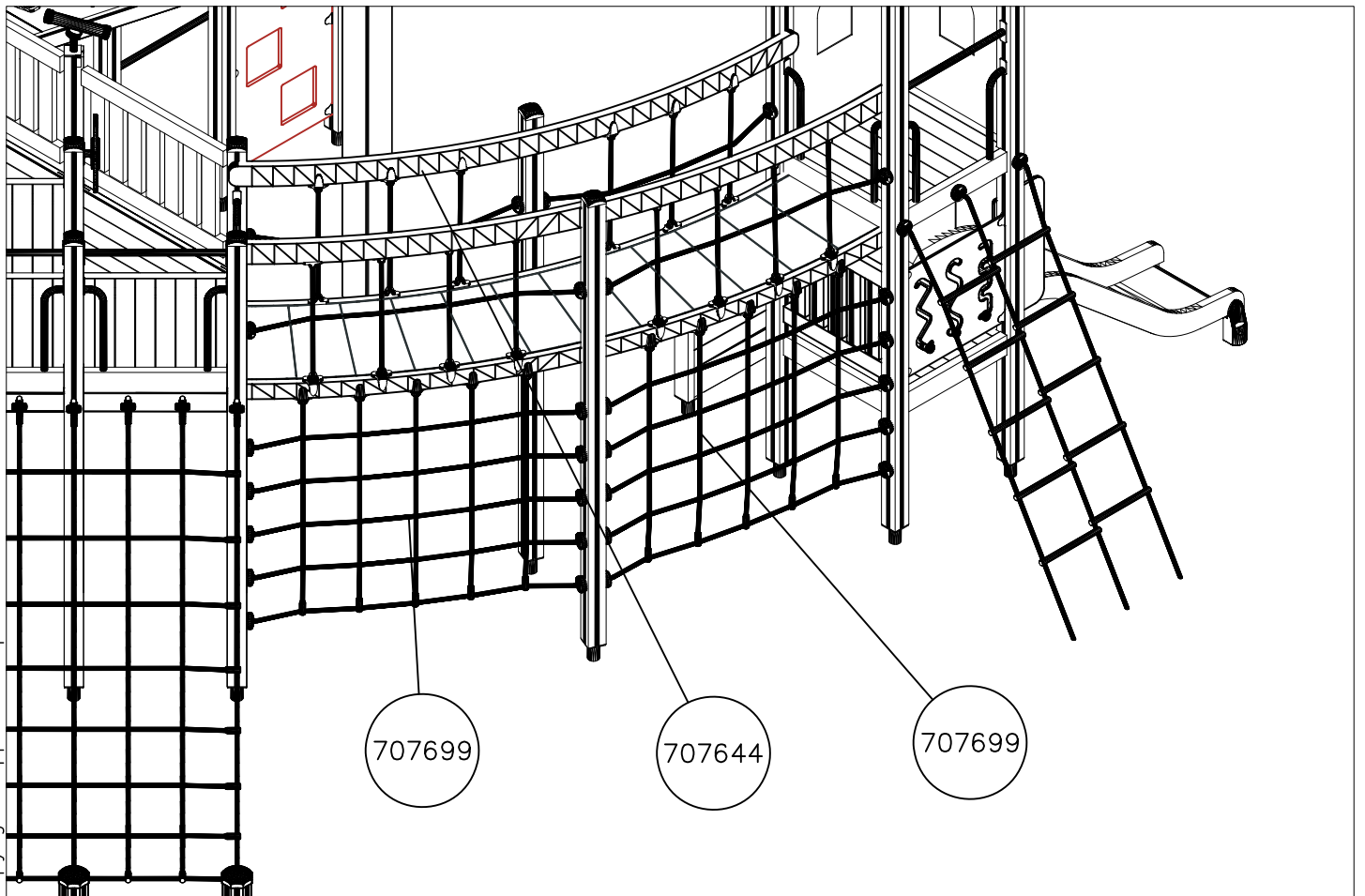
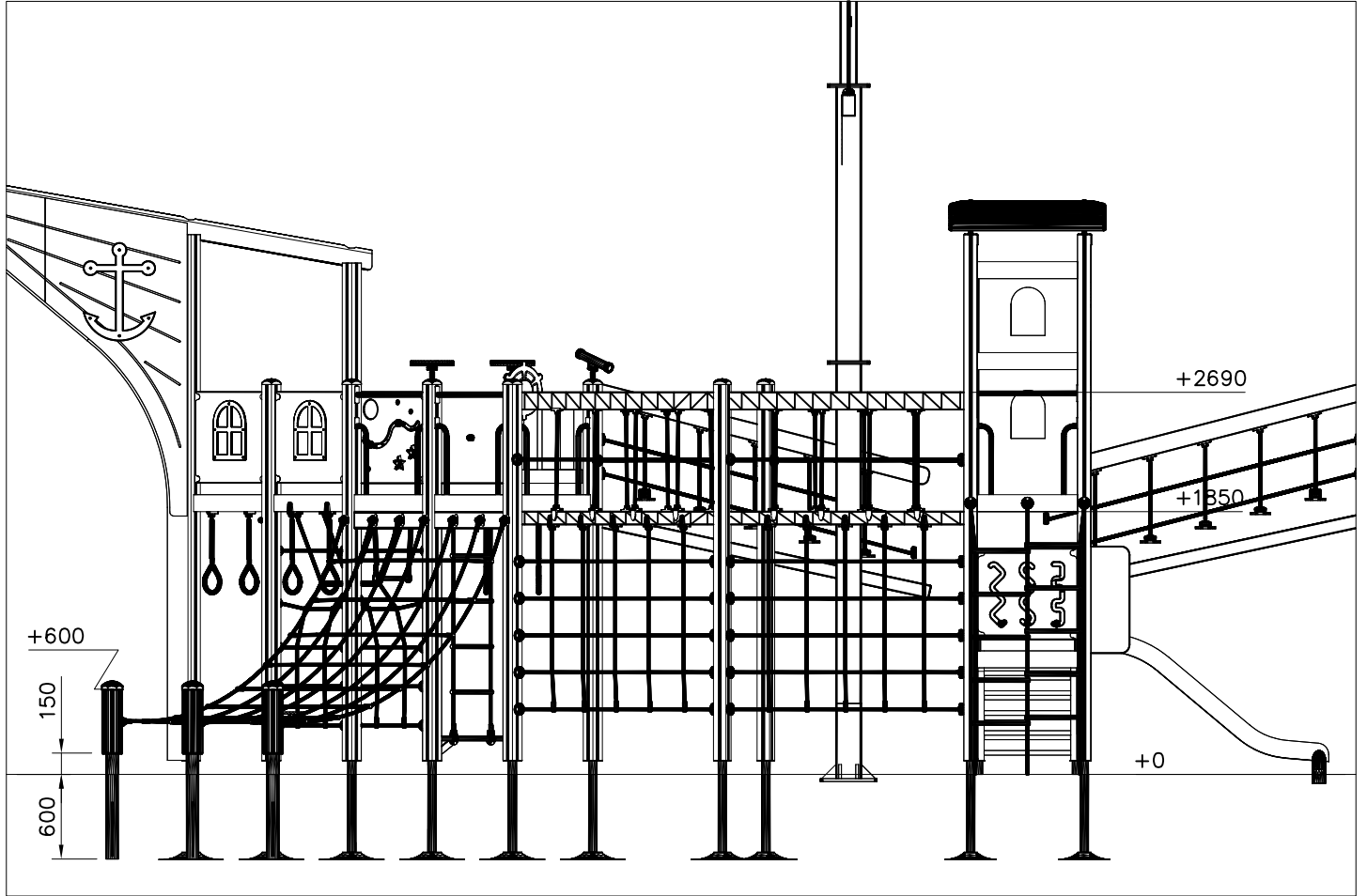

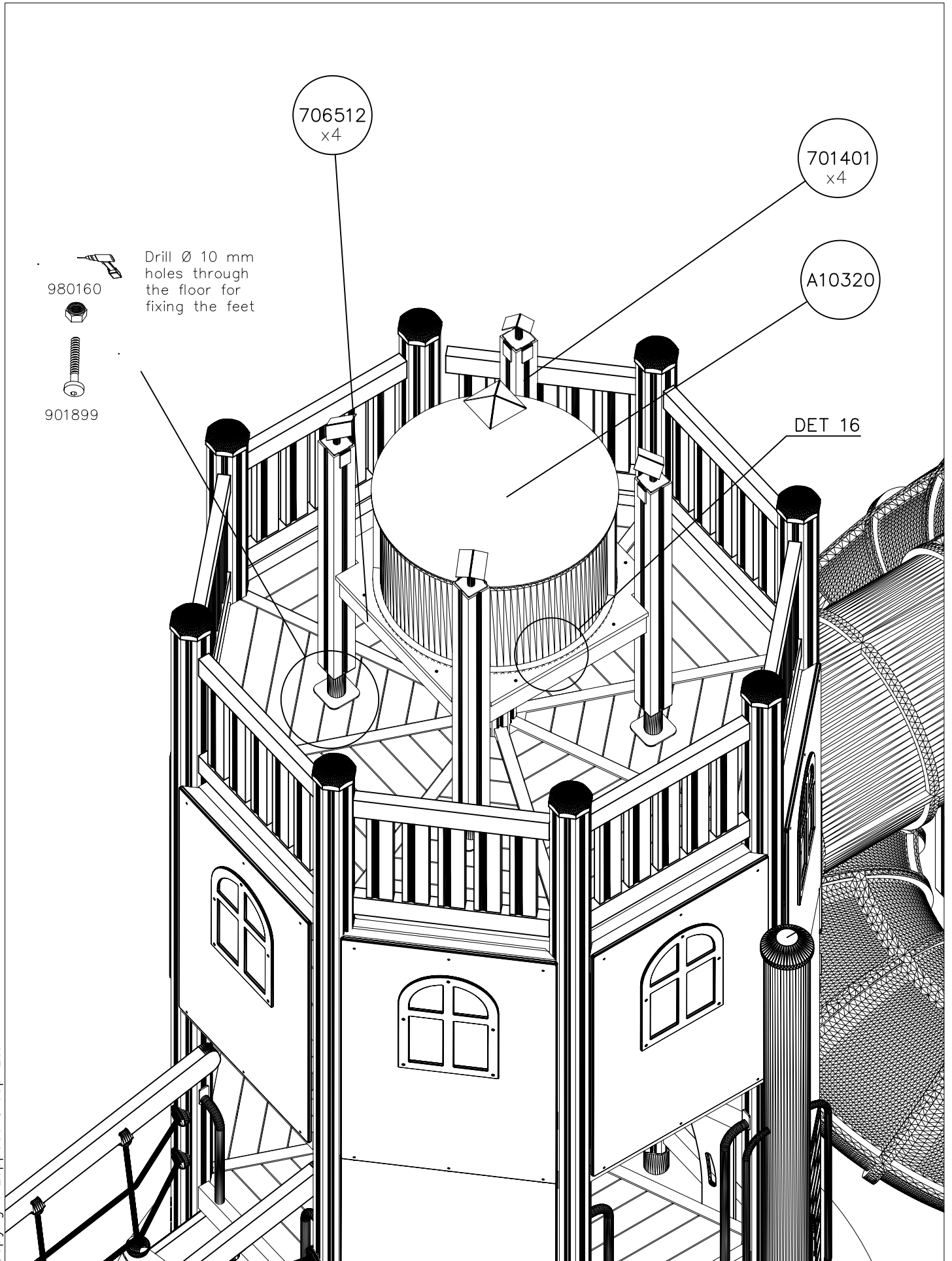





1. Tarkista tuoteosaluettelon ja osiin merkittyjen tuotenumeroiden avulla, että kaikki osat sisältyvät toimitukseen.
2. Valitse välineelle paikka ottaen huomioon valmistajan asennusohjeessa ilmoittamat turvaetäisyydet. Valitessasi välineen asennussuuntaa, huomioi mahdollinen altistuminen voimakkaalle auringonpaisteelle tai tuulelle. Tasoita alue ja tee ohjeen mukaiset perustustyöt. Varmista, että perustusosien alapuolinen maa on **tiivistetty riittävästi**. Tarvittaessa pohjamaa tulee vaihtaa murskeeseen tai vastaavaan kantavaan maainekseen. Iskua vaimentavan pintamateriaalin vahvuus määräytyy laskentakaavan perusteella, joka esitetään perustusohjeen lisäsivulla.
3. Välineen rungon pystystysohje esitetään sivulla 6. Yksityiskohtaiset kuvat asennuksesta on koottu erillisille ohjesivuille, joissa ne on ryhmitelty kiinnitystavan mukaan. Runkoon kiinnitettävistä komponenteista on erilliset moduuliohjeet. Noudata valmistajan asennusohjeessa ilmoittamia mitoituksia.
4. Tarkasta, että väline on suorassa ja perustukseltaan tukeva. Syväperusteisissa välineissä on suoritettava **riittävä maan tiivistäminen** kaivantojen täytön yhteydessä.
5. Tee käyttöönottotarkastus ennen välineen käyttöönottoa toimitukseen sisältyvän pöytäkirjan mukaisesti. Pöytäkirja tulee dokumentoida. Muista, että pääsy välineeseen tulee estää, kunnes se on valmis, turvallinen ja kaikki asennustarvikkeet on viety pois.

1. Kontrollera stycklistan och delarna i förpackningen med hjälp av produktnumren.
2. När du väljer platsen för utrustningen bör du beakta de säkerhetsavstånd som tillverkaren meddelat i monteringsanvisningarna. När du väljer monteringsriktning måste du beakta eventuell exponering för solsken eller vind. Jämna ut underlaget och utför grundarbetet i enlighet med instruktionerna. Säkra att marken under fundamentet är tillräckligt komprimerad. Vid behov kan man ersätta jorden med krossad sten eller motsvarande bärande jordmaterial. Styrkan på det slagdämpande ytmaterialet bestäms med hjälp av beräkningsformeln som presenteras på fundamentinstruktionernas tilläggsida.
3. Monteringsanvisningarna till utrustningens stomme finns på sidan 6. Detaljerade bilder av installationen har samlats på separata instruktionssidor, där de har grupperats enligt monteringsmetod. Det finns specifika modulanvisningar till de komponenter som ska sättas fast i stommen. Följ de dimensioner som tillverkaren gett i monteringsanvisningarna.
4. Kontrollera att utrustningen står rakt och stabilt. För utrustningar med djupt fundament måste man komprimera jorden ordentligt när man fyller igen groparna.
5. Innan utrustningen tas i bruk ska en slutbesiktning i enlighet med protokollet i leveransen utföras. Protokollet måste dokumenteras. Kom ihåg att tillträde till utrustningen måste förhindras tills den är färdig monterad, säker och alla monteringsstillbehör avlägsnats.

1. Use the parts list and the markings on the components to make sure that you have all of the necessary parts.
2. Choose a location for the product, taking into account the safety margins specified in the mounting instructions. When deciding on the orientation of the product, pay attention to potential sun and wind loads. Level the ground and prepare the foundations as instructed. Make sure that the ground underneath the foundations is solidly packed. If necessary, replace soil with wood chips or some other sturdy material. The thickness of the safety surfacing should be calculated using the formula supplied with the mounting instructions.
3. Assemble the frame of the product in accordance with the instructions on page 6. Detailed instructions for the different mounting alternatives are shown in the supplement. Separate instructions are provided for the modular components that will be attached to the frame. Please follow the stated measurements carefully.
4. Make sure that the product is mounted straight and firmly into the ground. Remember to pack the soil carefully when refilling the excavation around deep-mounted structures.
5. Inspect the installation thoroughly using the checklist provided. Document the completed checklist carefully. Remember to stop children from using the product until it has been fully built and safety-tested and all mounting equipment has been cleared away.

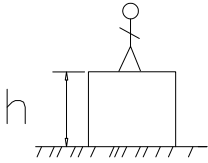
1. Überprüfen Sie die Lieferung auf Vollständigkeit, indem Sie das Teileverzeichnis mit der Lieferung abgleichen.
2. Wählen Sie einen Standort für das Gerät und berücksichtigen Sie die vom Hersteller in der Installationsanleitung genannten Sicherheitsabstände. Bei der Ausrichtung des Gerätes beachten Sie den möglichen Einfluss von starker Sonneneinstrahlung oder Wind. Ebenen Sie den Bereich und führen Sie die Fundamentarbeiten nach der Anleitung durch. Stellen Sie sicher, dass der Boden unter den Fundamentteilen ausreichend verdichtet ist. Wenn nötig, muss das Untergrundmaterial durch Split oder ein anderes tragfähiges Material ausgetauscht werden. Die Stärke des stoßdämpfenden Oberflächenmaterials wird auf Grundlage einer Formel berechnet, die im Anhang der Anleitung für die Fundamente dargestellt ist.
3. Die Aufbauanleitung für den Rahmen des Gerätes finden Sie auf Seite 6. Detaillierte Bilder der Installation sind auf gesonderten Anleitungsseiten zusammengestellt, auf denen sie nach ihrer Befestigungsweise geordnet sind. Für die am Geräterahmen befestigten Komponenten gibt es besondere Modulanleitungen. Halten Sie die in der Installationsanleitung vom Hersteller genannten Maße ein.
4. Überprüfen Sie, dass das Gerät in Waage steht und sicher am Boden verankert ist. Bei Geräten mit Tiefenfundamenten muss der Boden beim Auffüllen des Aushubs ausreichend verdichtet oder betoniert werden.
5. Führen Sie eine Inbetriebnahmeüberprüfung entsprechend des im Lieferumfang enthaltenen Protokolls durch, bevor das Gerät benutzt wird. Das Protokoll muss aktenkundig dokumentiert werden. Denken Sie daran, dass der Zugang zum Gerät verhindert werden muss, bis es fertig und sicher ist und alle Installationswerkzeuge entfernt sind.

1. Vérifier à l'aide de la liste des pièces et des numéros de produit marqués sur les pièces que la livraison comprend toutes les pièces nécessaires.
2. Choisir un bon emplacement pour l'équipement, compte tenu des distances de sécurité indiquées par le fabricant dans les instructions de montage. Tenir compte de l'exposition éventuelle aux forts rayons de soleil ou au vent lors du choix du sens de montage de l'équipement. Egaliser la surface de l'emplacement choisi et effectuer les travaux de fondation conformément aux instructions. S'assurer que le sol sous les pièces de fondation a été suffisamment compacté. Si besoin est, le sol de fondation doit être remplacé par des pierres concassées ou un matériau portant similaire. L'épaisseur du matériau de surface anti-choc est calculée selon la formule indiquée à la page supplémentaire des instructions de fondation.
3. Les instructions d'érection de l'ossature de l'équipement sont indiquées à la page 6. Les images détaillées du montage sont adjointes aux pages d'instruction séparées où elles sont groupées selon le mode de fixation. Des instructions modulaires séparées sont données pour les composants à fixer sur l'ossature. Respecter les mesures données par le fabricant dans les instructions de montage.
4. Vérifier que l'équipement est droit et que sa fondation est solide. Dans le cas des équipements dont la fondation se trouve sous le sol, le sol doit être suffisamment compacté lors du remplissage des trous.
5. Effectuer un contrôle de mise en service conforme au procès-verbal compris dans la livraison avant la mise en service de l'équipement. Ce procès-verbal doit être documenté. Ne pas oublier d'empêcher l'accès à l'équipement jusqu'à ce que celui-ci soit prêt et sûr et que tous les outils de montage aient été enlevés.

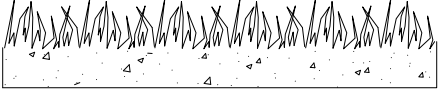
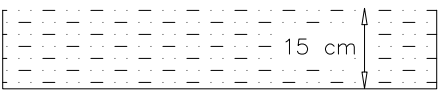
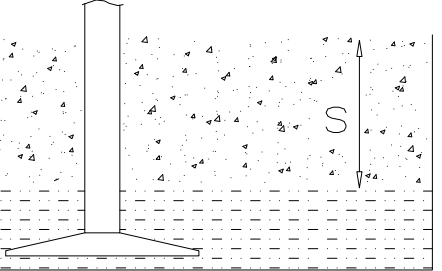
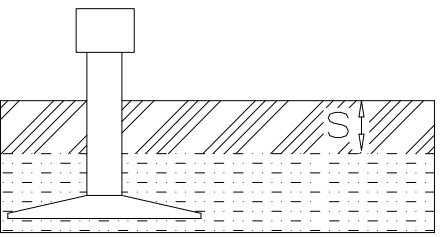
												
<p>$h < 600$</p> <p>Without movement and therefore without Impact Area</p>	<p>Totally hard surfaces.</p> <p>Note. Lappset does <u>not recommend</u> totally hard surfaces at all.</p>	<p>E.g. concrete or asphalt</p> 										
<p>$h < 600$</p> <p>With movement e.g. rocking</p>	<p>Materials with very limited impact attenuating properties.</p>	<p>E.g. wood</p> 										
<p>$h < 1000$</p>	<p>Materials with significant impact attenuating properties.</p>	<p>fine gravel 0–8 mm</p>  <p>grass</p>  <p>unsorted sand</p> 										
<p>$h < 3000$</p>	<p>Loose fill material</p> <p>E.g. sand/gravel 0,25...8 mm D60/D10<3,0 Woodchips 5...30 mm bark 20...80 mm</p>	 <table data-bbox="1021 1691 1332 1792"> <tr> <td>\underline{S}</td> <td>\underline{h}</td> </tr> <tr> <td>30 cm</td> <td>< 2,0 m</td> </tr> <tr> <td>40 cm</td> <td>< 3,0 m</td> </tr> </table>	\underline{S}	\underline{h}	30 cm	< 2,0 m	40 cm	< 3,0 m				
\underline{S}	\underline{h}											
30 cm	< 2,0 m											
40 cm	< 3,0 m											
	<p>Syntethic granulates</p> <table data-bbox="406 1892 758 2060"> <tr> <td>\underline{S}</td> <td>\underline{h}</td> </tr> <tr> <td>40 mm</td> <td>~> 1,2...1,3 m</td> </tr> <tr> <td>50 mm</td> <td>~> 1,5...1,7 m</td> </tr> <tr> <td>60 mm</td> <td>~> 1,8...2,0 m</td> </tr> <tr> <td>70 mm</td> <td>~> 2,1...2,5 m</td> </tr> </table> <p>Note. For accurate values, see manufacturer's instructions.</p>	\underline{S}	\underline{h}	40 mm	~> 1,2...1,3 m	50 mm	~> 1,5...1,7 m	60 mm	~> 1,8...2,0 m	70 mm	~> 2,1...2,5 m	
\underline{S}	\underline{h}											
40 mm	~> 1,2...1,3 m											
50 mm	~> 1,5...1,7 m											
60 mm	~> 1,8...2,0 m											
70 mm	~> 2,1...2,5 m											



REMOVE SAFETY SURFACE/SAND/GRAVEL
TO CHECK FOUNDATION

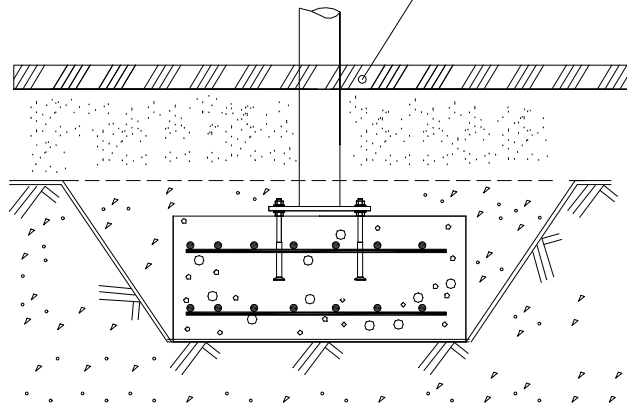

REMOVE SAFETY SURFACE/SAND/GRAVEL
TO CHECK FOUNDATION

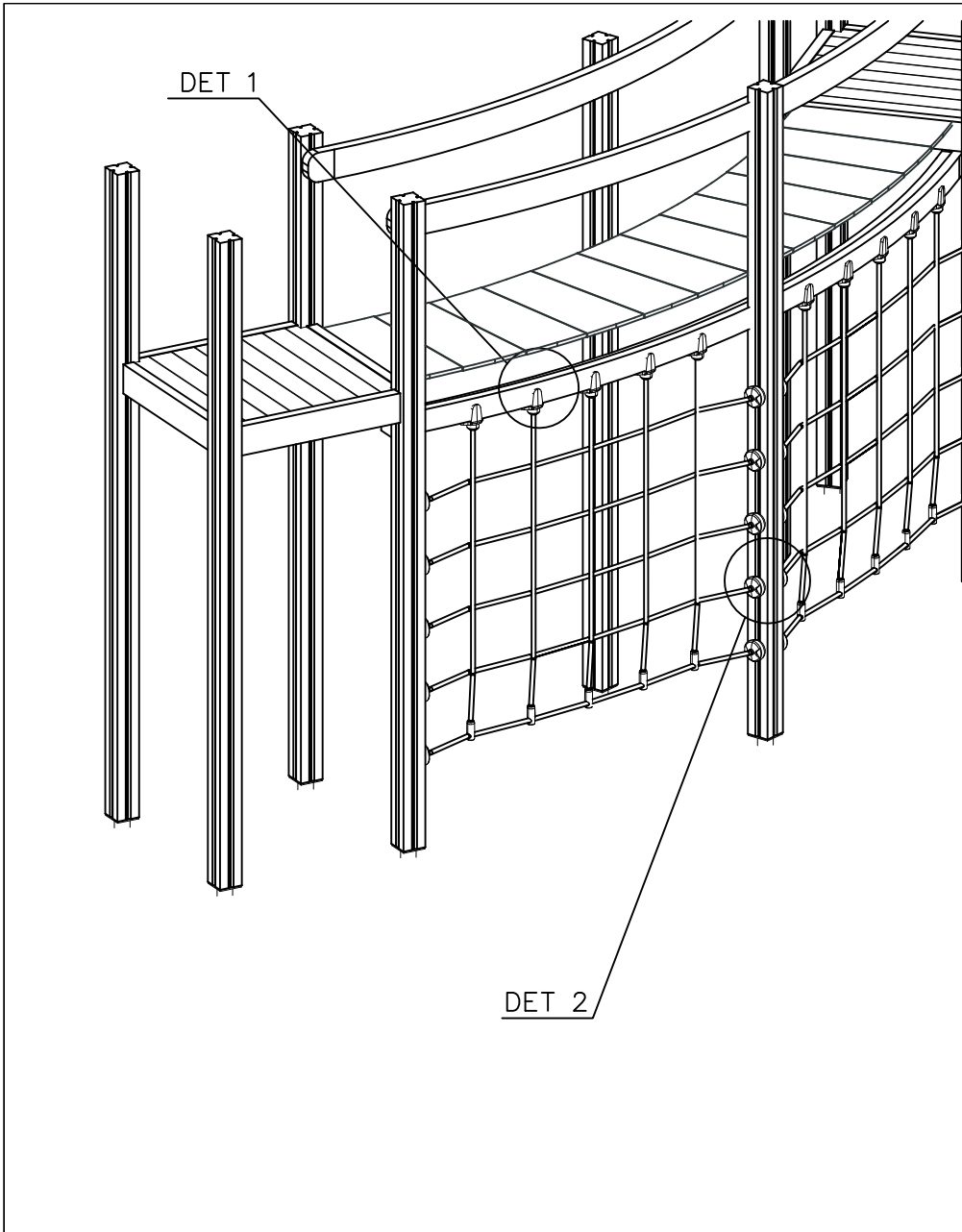

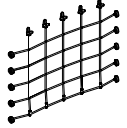

①	900240	PCS	②	980128	PCS
		20			5
					
	Ø8x70			Ø7x40	
③	980123	PCS			PCS
		10			
					
	Ø7x60				
		PCS			PCS
		PCS	○	707686	PCS
					1
				1350x1240	

ROPE COLOR OPTIONS

- 301 BLUE
- 302 RED
- 303 BEIGE
- 304 GRAY
- 305 BLACK
- 306 YELLOW

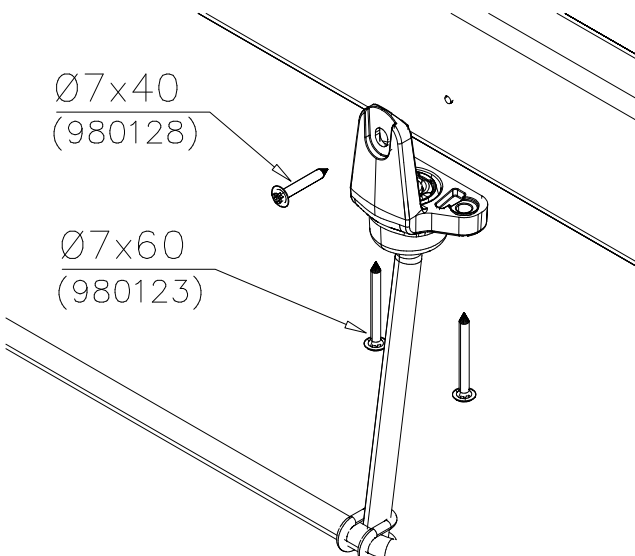

DET 1



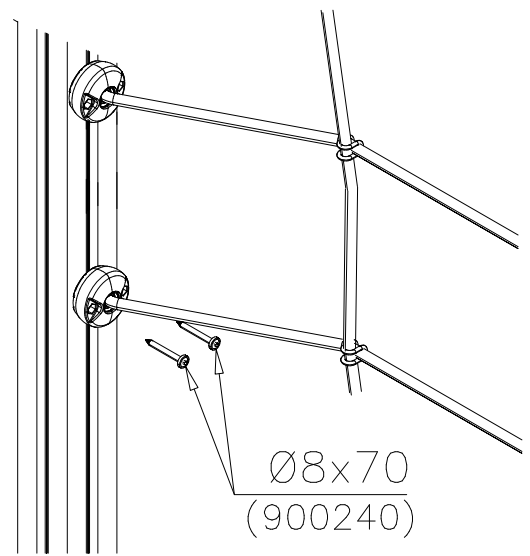

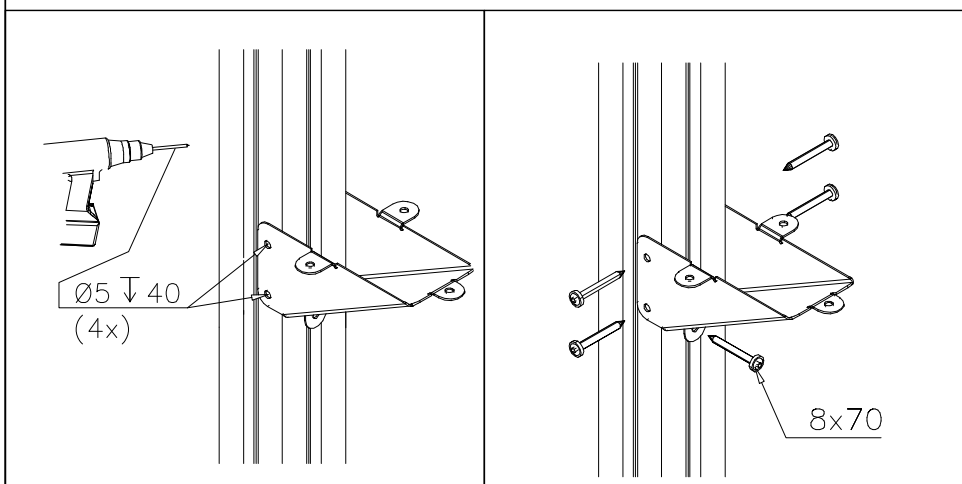
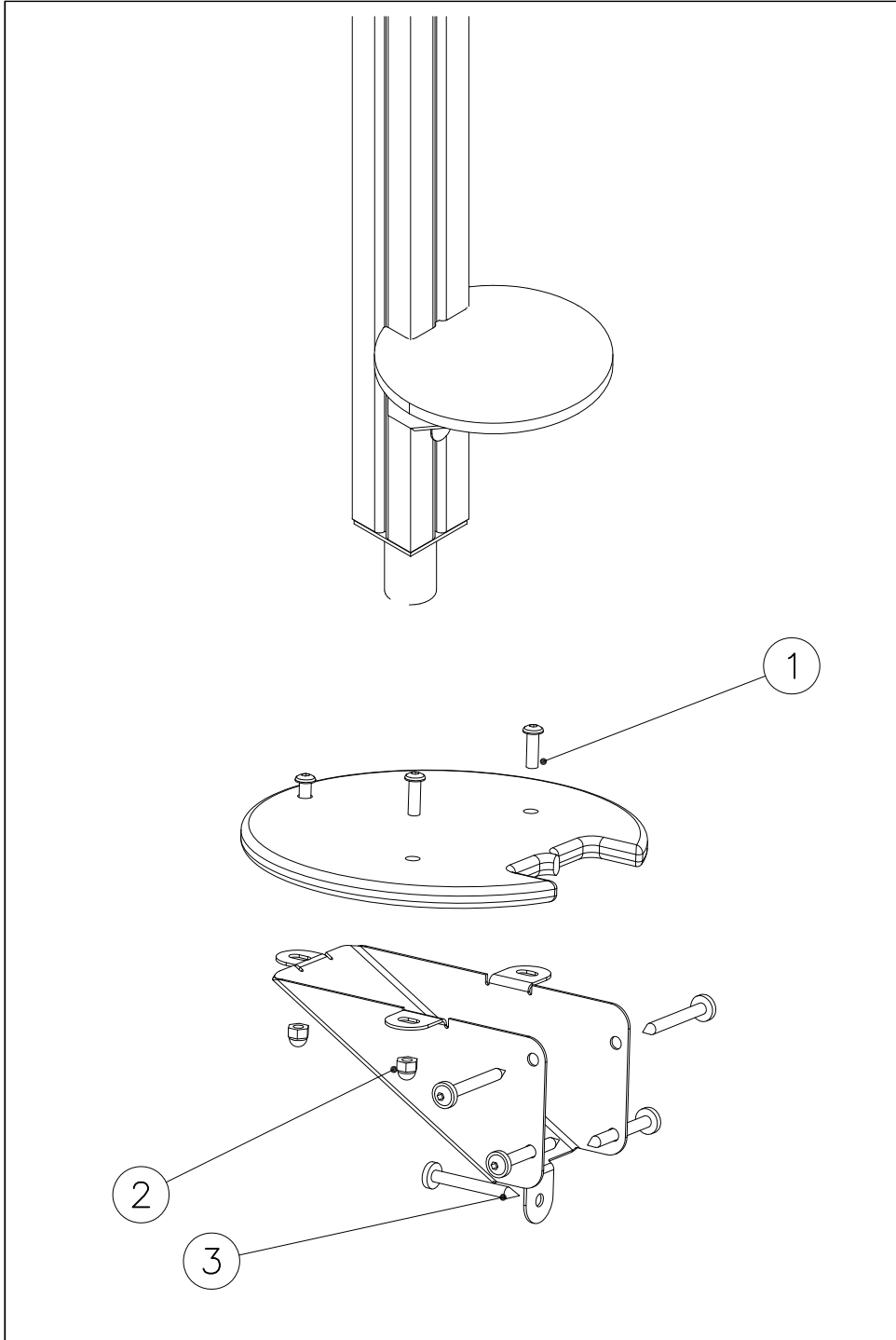

DET 2

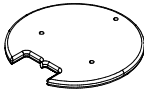
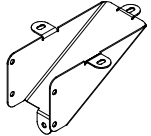

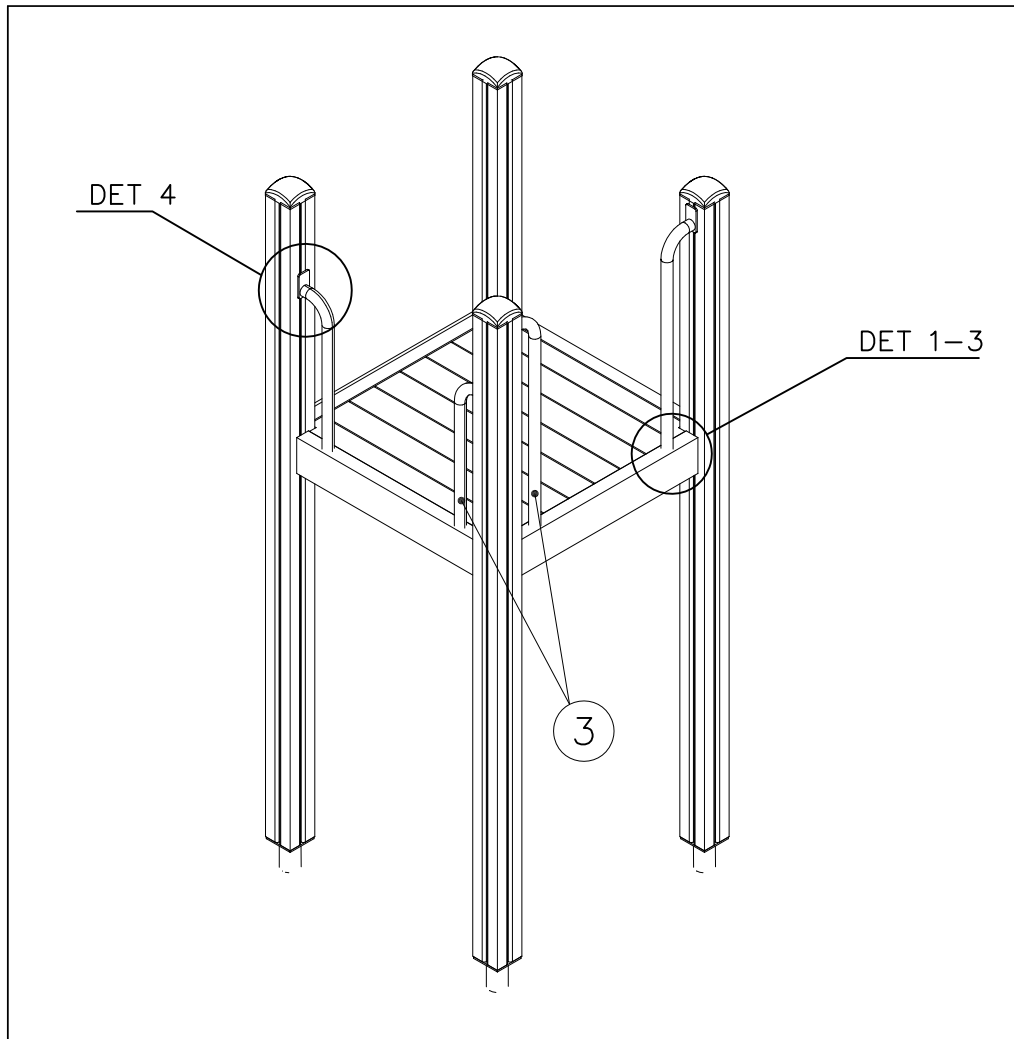

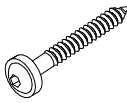
①	909850	PCS	②	909633	PCS
		3			3
	M8x25			M8	
③	900240	PCS			PCS
		5			
	Ø8x70				
		PCS			PCS
○	707696	PCS	○	902086	PCS
		1			1
	15x265x275			148x172x254	
		PCS			PCS
		PCS			PCS
		PCS			PCS
		PCS			PCS



① 900240  Ø8x70	PCS 1	② 900727  M10x80	PCS 1
	PCS		PCS
③ 907688  765	PCS 1	③ 907701  545	PCS 1
	PCS		PCS
	PCS		PCS
	PCS		PCS
	PCS		PCS
	PCS		PCS
	PCS		PCS

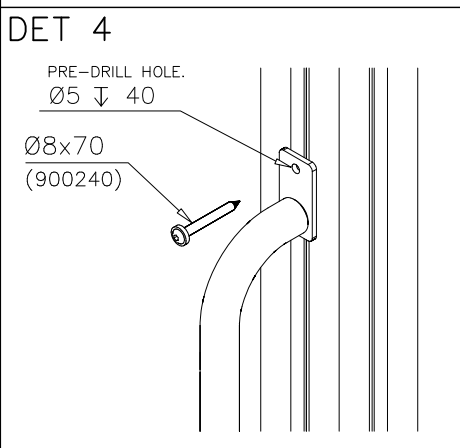
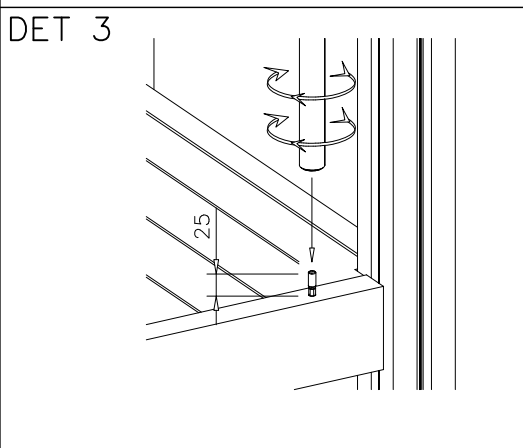
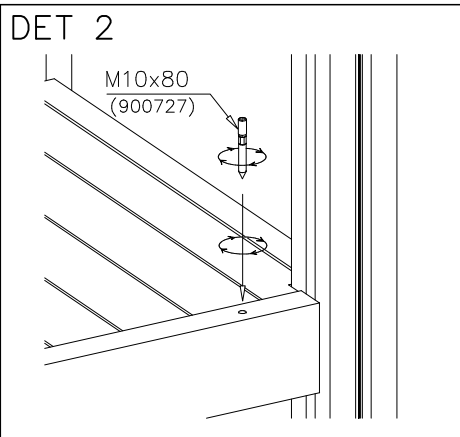
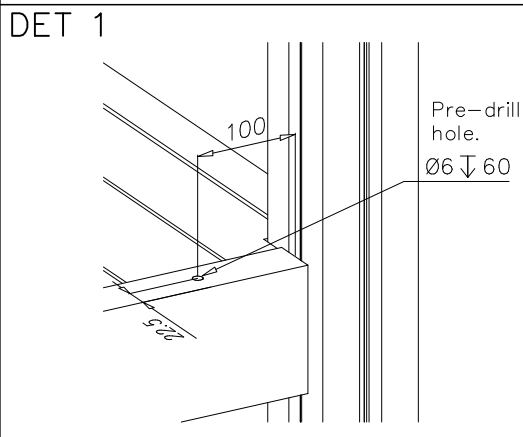

Huom. Pystyttäessä tube- liukumäkeä korkean leikkivälineen yhteyteen, voidaan pystytystyössä tarvita nosturia, ellei paikalla ole tarpeeksi pystytyshenkilökuntaa.

1. Tarkista tuoteosaluettelon ja osiin merkittyjen tuotenumeroitten avulla, että kaikki osat sisältyvät toimitukseen.
2. Valitse välineelle paikka ottaen huomioon valmistajan asennusohjeessa ilmoittamat turvaetäisyydet, 2m turvaetäisyys jarrutuslaatikon edessä ja 1m sivuilla. Tube liukumäen alastuloalueen on vastattava 1m putoamiskorkeutta. Tee tarvittavat peruskaivannot jarrutuslaatikkoa varten.
3. Kokoa kehät sivujen 4 ja 5 mukaisesti huomioiden läpinäkyvät osat.
4. Liitä kehät toisiinsa asennusohjeen numeromerkintöjen mukaan. Sivulla 6 esitetään esimerkki kehien kokoamisesta. Huomioi ettei läpinäkyviä osia tule liukupintaan.
5. Asenna esikoottu lähtölevy putken yläpäähän ohjeen mukaiseen asentoon. Asenna jarrutuslaatikon 905850 perustusraudat asennusohjeen mukaisesti ja liitä putken alapäähän.
6. Nosta putkiliukumäki rakennelmaa vasten ja kiinnitä ohjeen mukaisilla kiinnikkeillä. Täytä jarrutuslaatikon alusta hiekalla.
7. Asenna mahdolliset liukumäen tukitolpat erillisen ohjeen mukaan.
8. Tee käyttöönottotarkastus ennen välineen käyttöönottoa toimitukseen sisältyvän pöytäkirjan mukaisesti. Pöytäkirja tulee dokumentoida. Muista, että pääsy välineeseen tulee estää, kunnes se on valmis, turvallinen ja kaikki asennustarvikkeet on viety pois.

Obs. När du lyfter upp en tuberutschbana mot en hög lekutrustning, kan det hända att du behöver använda en kran om det inte finns monteringspersoner på plats.

1. Kontrollera stycklistan och delarna i förpackningen med hjälp av produktnumren.
2. När du väljer platsen för utrustningen bör du beakta de säkerhetsavstånd som tillverkaren meddelat i monteringsanvisningarna. 2 m säkerhetsavstånd framför bromslådan och 1 m på sidorna. På Tubes- rutschbanan landningsområde måste det finnas motsvarande 1 m fallhöjd. Utför nödvändigt grundarbete för bromslådan.
3. Montera ringarna enligt sidorna 4 och 5 och beakta de genomskinliga delarna.
4. Montera ihop ringarna med varandra enligt numren i monteringsanvisningarna. På sidan 6 får du ett exempel på hur man monterar ringarna. Observera att det inte får komma några genomskinliga delar på glidytan.
5. Sätt fast den förmonterade startskivan på den övre delen enligt anvisningarna. Sätt fast bromslådan i enlighet med monteringsanvisningarna för fundamentjärnen 905850 och sätt fast i den nedre delen av röret.
6. Lyft upp tubrutschbanan mot konstruktionen och fäst med fästelement enligt anvisningarna. Fyll botten av bromslådan med sand.
7. Montera eventuella stöd Stolpar till rutschbanan enligt separata anvisningar.
8. Innan utrustningen tas i bruk ska en slutbesiktning i enlighet med protokollet i leveransen utföras. Protokollet måste dokumenteras. Kom ihåg att tillträde till utrustningen måste förhindras tills den är färdig monterad, säker och alla monteringsstillbehör avlägsnats.

Please note! In the absence of sufficient installation staff you may need to use a crane to attach the Tube slide to a tall structure.

1. Use the parts list and the markings on the components to make sure that you have all of the necessary parts.
2. Choose a location for the product, taking into account the safety margins specified in the mounting instructions: leave 2 metres in front of the slide's end and 1 metre on both sides. The curve of the Tube slide must correspond to a total fall height of 1 metre. Prepare the ground for anchoring the end piece.
3. Assemble the tubular components in accordance with the instructions on pages 4 and 5, taking into account the positioning of transparent elements.
4. Join the components together following the numbering in the instructions. An example of how to assemble the tube is shown on page 6. Make sure that none of the transparent elements are used for the sliding surface.
5. Pre-assemble the top deck and position it at the upper end of the slide as shown in the instructions. Fix the steel anchors on the bottom of the slide (part No 905850) into place as instructed and attach to the bottom end of the tube.
6. Lift the tube up against the structure and fix into place using the mountings provided. Fill the area in front of and underneath the slide with sand.
7. Follow the instructions in the supplement to mount support posts if required.
8. Inspect the installation thoroughly using the checklist provided. Document the completed checklist carefully. Remember to stop children from using the product until it has been fully built and safety-tested and all mounting equipment has been cleared away.









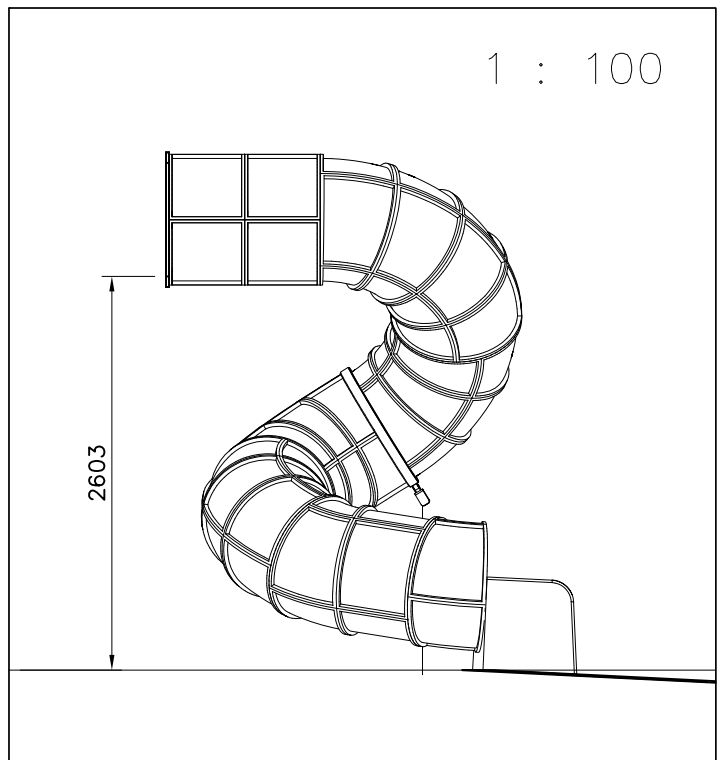
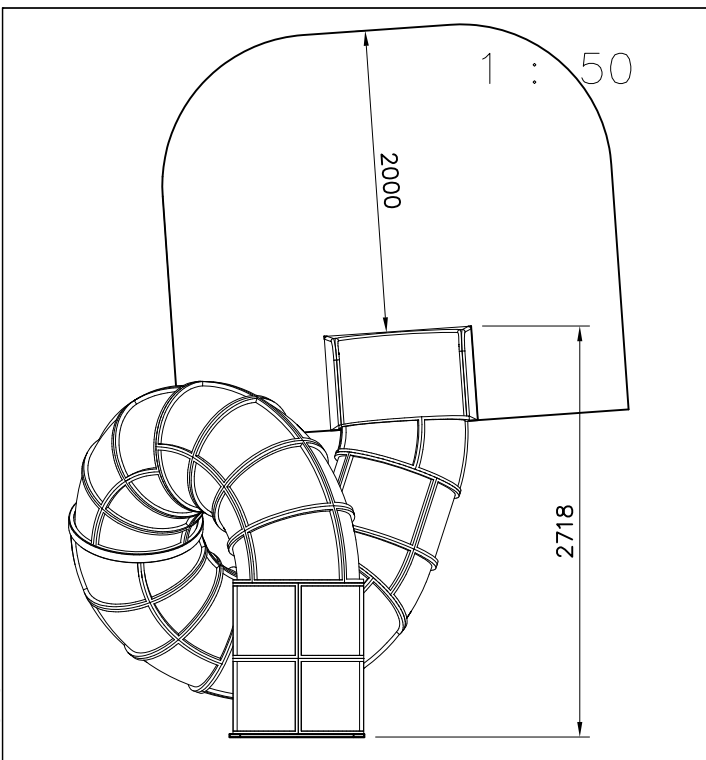
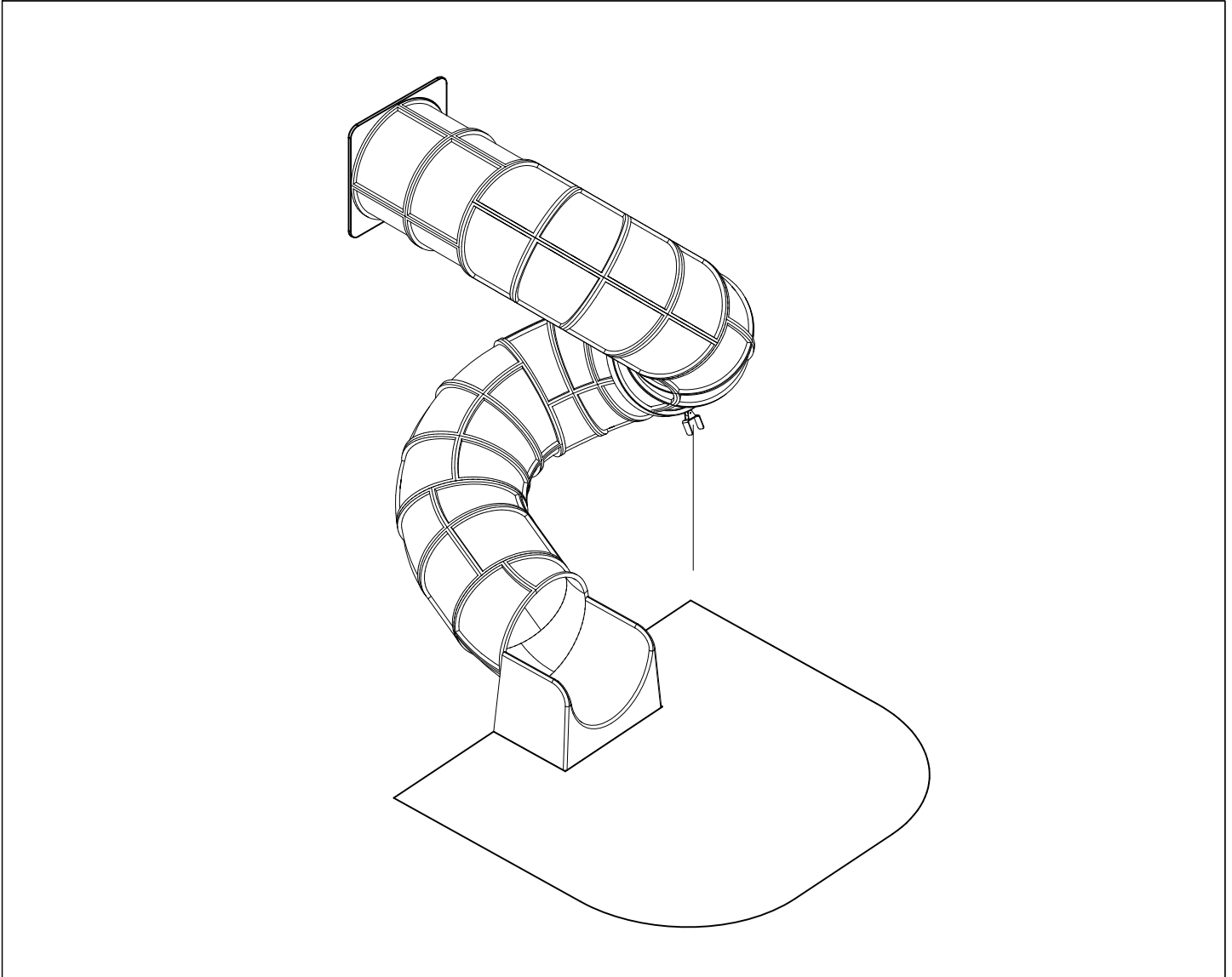

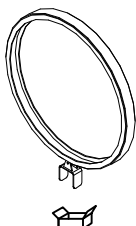
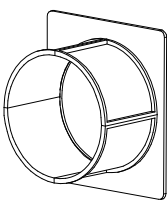
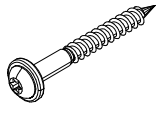
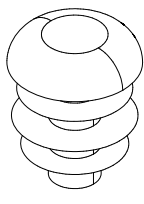
Zur Beachtung: Beim Aufstellen der Röhren-Rutschbahn in Verbindung mit einem hohen Spielgerät, ist evtl. für die Aufstellarbeiten ein Kran erforderlich, falls nicht ausreichend Installationspersonal vor Ort verfügbar ist.

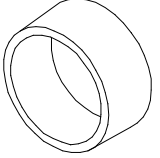
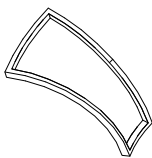
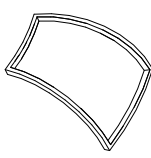
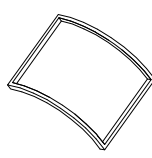
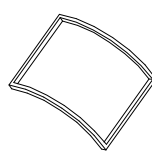
1. Überprüfen Sie die Lieferung auf Vollständigkeit, indem Sie das Teileverzeichnis mit der Lieferung abgleichen.
2. Wählen Sie einen Standort für das Gerät entsprechend der vom Hersteller in der Installationsanleitung genannten Sicherheitsabstände, 2 m Sicherheitsabstand vor dem Auslaufstück und 1m zur Seite. Der Auslaufbereich der Röhren-Rutschbahn muss 1m Fallhöhe entsprechen. Führen Sie die nötigen Aushubarbeiten für das Auslaufstück durch.
3. Bauen Sie entsprechend der Seiten 4 und 5 die Ringe unter Berücksichtigung der durchsichtigen Teile zusammen.
4. Verbinden Sie die Ringe entsprechend den in der Montageanleitung genannten Nummernmarkierungen. Auf Seite 6 finden Sie ein Beispiel für das Zusammenfügen der Ringe. Achten Sie darauf, dass keine durchsichtigen Teile auf die Rutschflächen kommen.
5. Befestigen Sie die vormontierte Ablaufplatte in der korrekten Position entsprechend der Anleitung am oberen Ende des Rohres. Montieren Sie die Fundamenteisen nach Anleitung am Auslaufstück 905850 und befestigen Sie es am unteren Ende.
6. Heben Sie die Röhrenrutschbahn an die Konstruktion und befestigen Sie sie mit den Befestigungsteilen entsprechend der Anleitung. Füllen Sie den Untergrund am Auslaufstück mit Sand auf.
7. Montieren Sie eventuelle Stützpfeiler der Rutschbahn nach einer gesonderten Anleitung.
8. Führen Sie eine Inbetriebnahmeüberprüfung entsprechend des im Lieferumfang enthaltenen Protokolls durch, bevor das Gerät benutzt wird. Das Protokoll muss aktenkundig dokumentiert werden. Denken Sie daran, dass der Zugang zum Gerät verhindert werden muss, bis es fertig und sicher ist und alle Installationsgeräte entfernt sind.

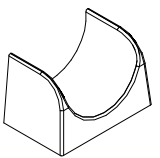
N.B. Lorsque le toboggan - tube est monté sur un équipement haut, une grue peut être nécessaire pour les travaux de montage s'il n'y a pas suffisamment de personnel de montage sur place.

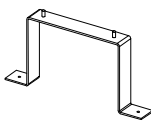
1. Vérifier à l'aide de la liste des pièces et des numéros de produit marqués sur les pièces que la livraison comprend toutes les pièces nécessaires.
2. Choisir un bon emplacement pour l'équipement, compte tenu des distances de sécurité indiquées par le fabricant dans les instructions de montage, une distance de sécurité de 2m devant la boîte de freinage et de 1m sur les côtés. La zone de descente du toboggan tube doit correspondre à une hauteur de descente d'un mètre. Effectuer les excavations de base pour la boîte de freinage.
3. Assembler les cadres conformément aux pages 4 et 5 en prenant en considération les pièces transparentes.
4. Relier les cadres les uns aux autres conformément aux numérotations des instructions de montage. Un exemple du montage des cadres est donné à la page 6. Veiller à ce que des pièces transparentes ne soient pas placées sur le côté glissement.
5. Monter la plaque de départ prémontée à l'extrémité supérieure du tube dans la position indiquée dans les instructions. Monter les fers de fondation 905850 de la boîte de freinage conformément aux instructions de montage et les relier à l'extrémité inférieure du tube.
6. Soulever le toboggan- tube contre la structure et le fixer à l'aide des pièces de fixation conformément aux instructions. Remplir le fond de la boîte de freinage avec du sable.
7. Monter les poteaux de support éventuels du toboggan conformément aux instructions séparées.
8. Effectuer un contrôle de mise en service conforme au procès-verbal compris dans la livraison avant la mise en service de l'équipement. Ce procès-verbal doit être documenté. Ne pas oublier d'empêcher l'accès à l'équipement jusqu'à ce que celui-ci soit prêt et sûr et que tous les outils de montage aient été enlevés.

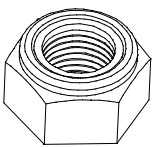
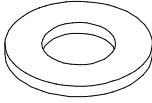

004914	PCS 1	707918-701	PCS 1	900240	PCS 14	903533	PCS 6	905086	PCS 4	905112	PCS 888
											
				Ø8x70		SRL12		Ø44/13.5		BLACK Ø22	
905801	PCS 28	905811	PCS 28	905821	PCS 3	905829	PCS 5	905831	PCS 816	905850	PCS 1
											
GREY		GREY		GREY		TRANSPARENT		BLACK			
905859	PCS 2	905860	PCS 2	909205	PCS 408	909248	PCS 4	909274	PCS 4	980150	PCS 412
											
6x80x850				8x60		M12		8x30		M8	
980151	PCS 8		PCS		PCS		PCS		PCS		PCS
											
Ø16/8.4											
	PCS		PCS		PCS		PCS		PCS		PCS
	PCS		PCS		PCS		PCS		PCS		PCS

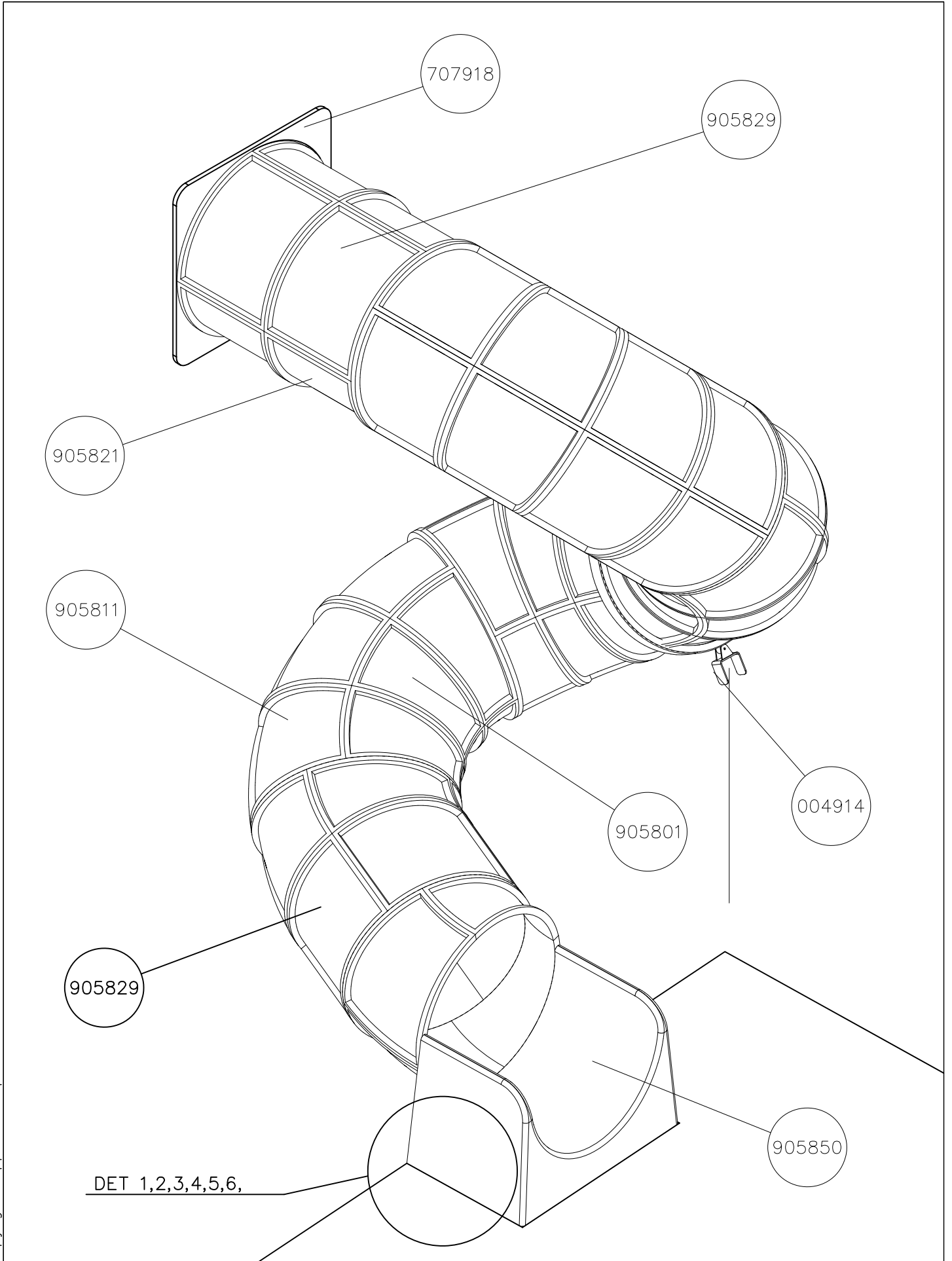

DET 1

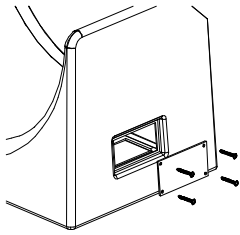
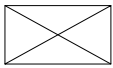

Access- and maintenance panel.
Asennus- ja huolto luukku.

DET 2

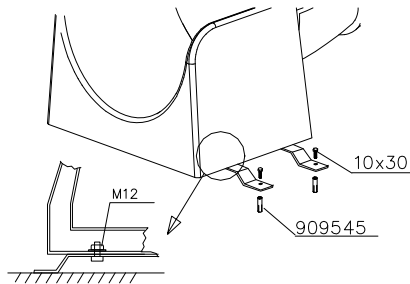

DET 3

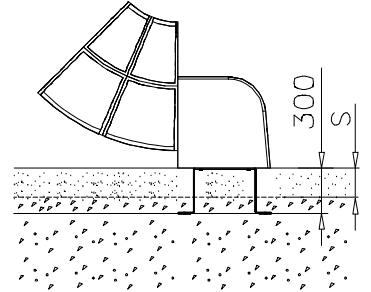
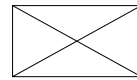

DET 4

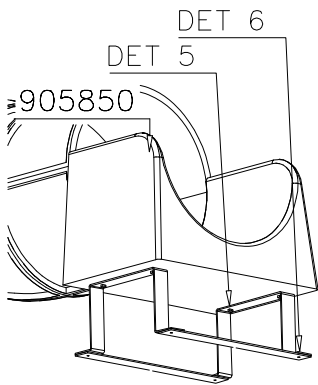

DET 5

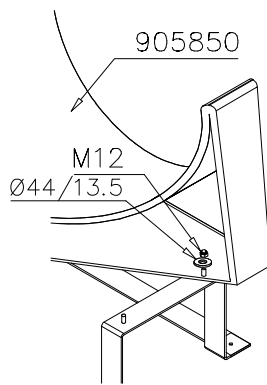

DET 6

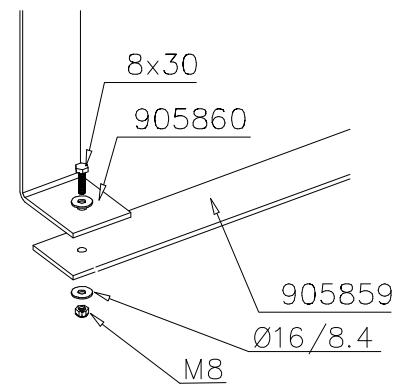

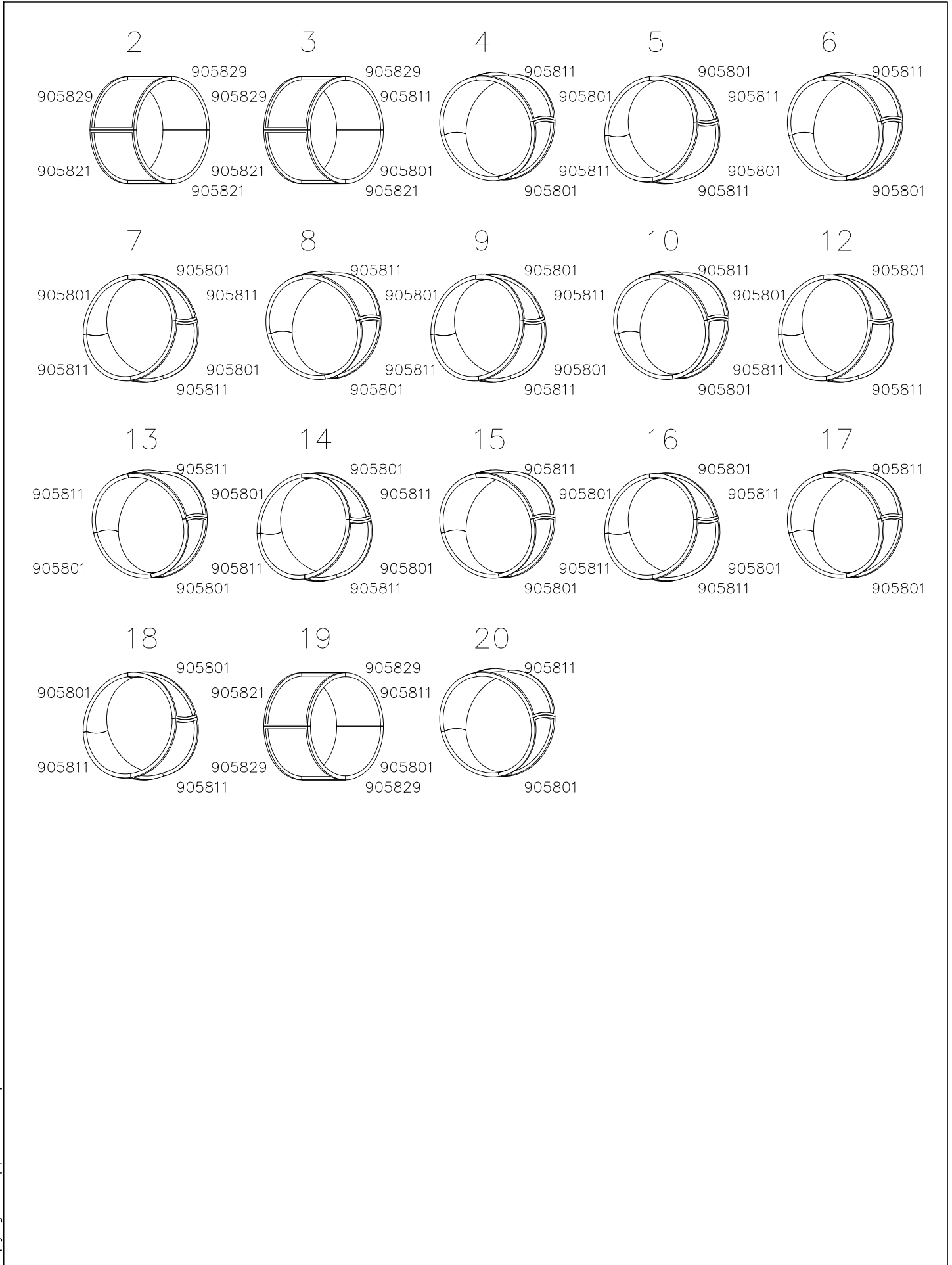

Esimerkki putken kokoamisesta
Example of installation





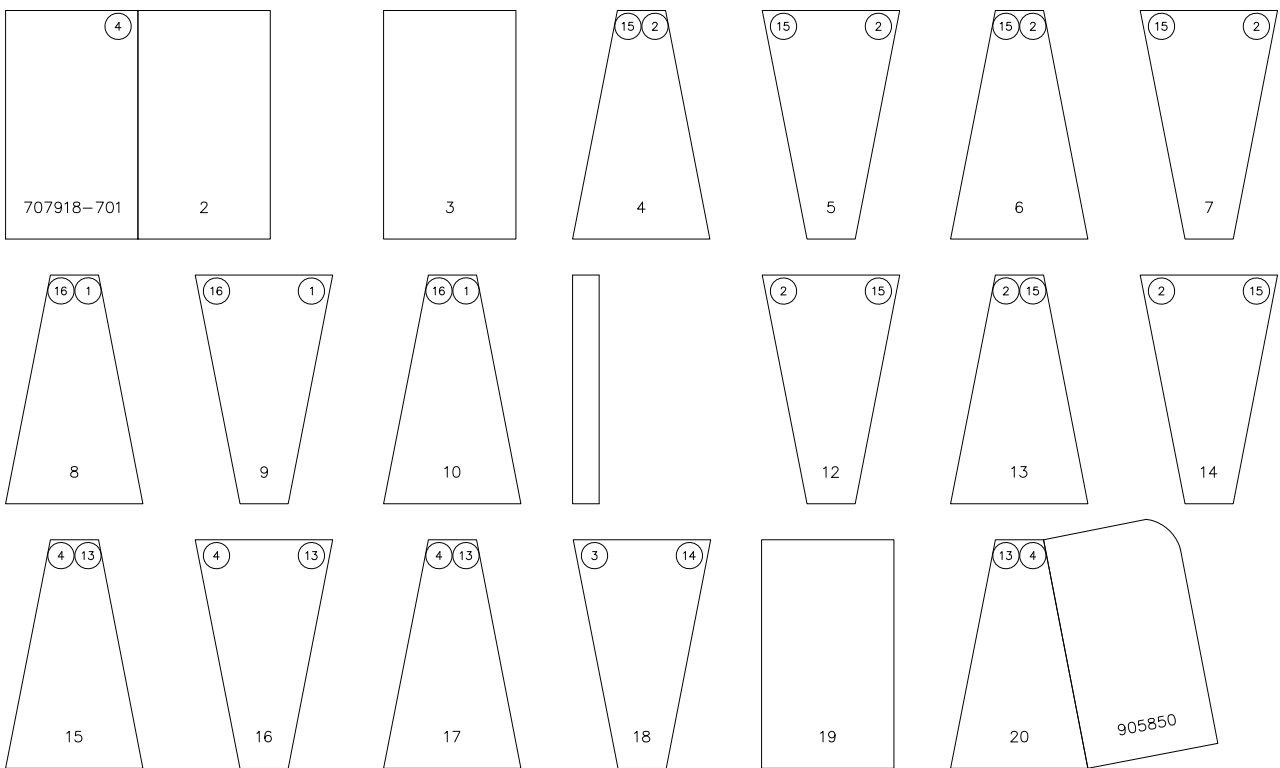
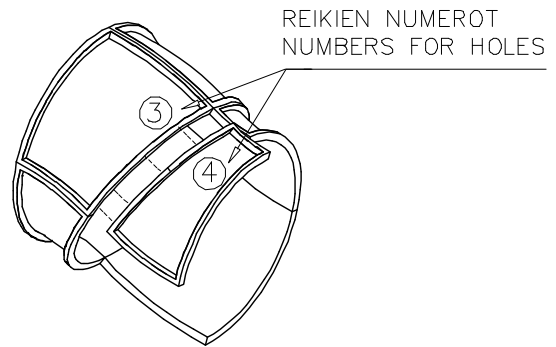

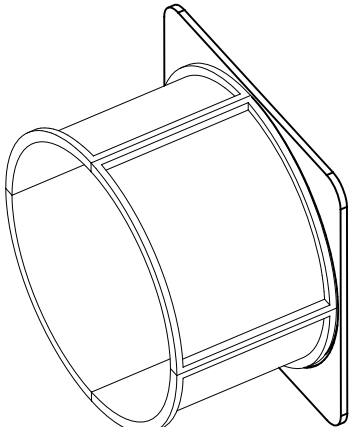
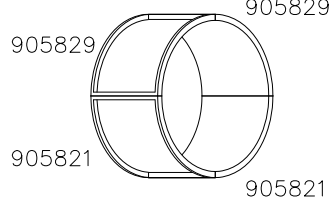
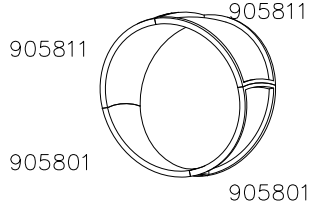

LIUKUPINTAAN EI SAA TULLA
LÄPINÄKYVIÄ MODUULEJA!!

NO TRANSPARENT PIECES ON
SLIDING SURFACE!!



Valmiiksi kasattujen osien osakokoonpanot ja vara-osa listat.

Ready installed component subassemblies and spare part list.

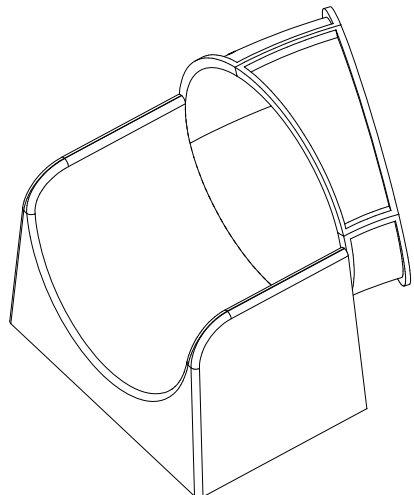
	<p>2</p> 								
<p>20</p>  <table border="1" data-bbox="167 1724 742 2094"> <tr> <td>909205 x 16 909206 x 8</td> <td>980150 x 16</td> <td>905831 x 32</td> </tr> <tr> <td>905850</td> <td>909208 x 8</td> <td>980151 x 8</td> </tr> </table> <p>Position of the box: 16 degrees</p>	909205 x 16 909206 x 8	980150 x 16	905831 x 32	905850	909208 x 8	980151 x 8	<p>707918-701</p> 	<p>909205 x 12</p> 	<p>980150 x 12</p> 
909205 x 16 909206 x 8	980150 x 16	905831 x 32							
905850	909208 x 8	980151 x 8							
	<p>905831 x 40</p> 	<p>909208 x 16</p> 	<p>909119 x 16</p> 						
	<p>909252 x 13</p> 	<p>700413 x 1</p> 							

DATE: 25.10.2024

DET 1

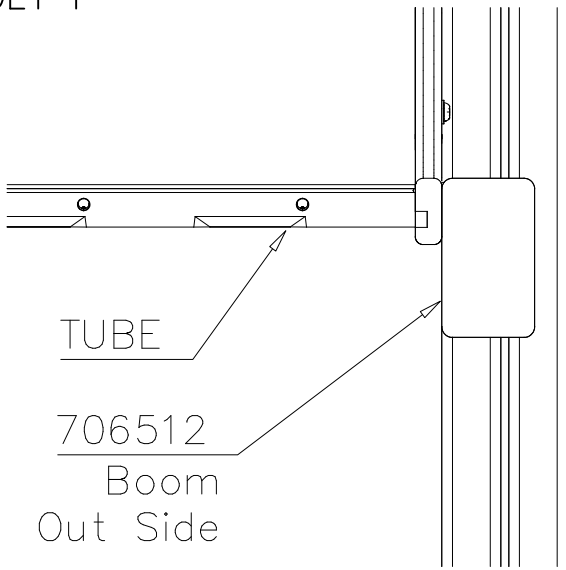

DET 2

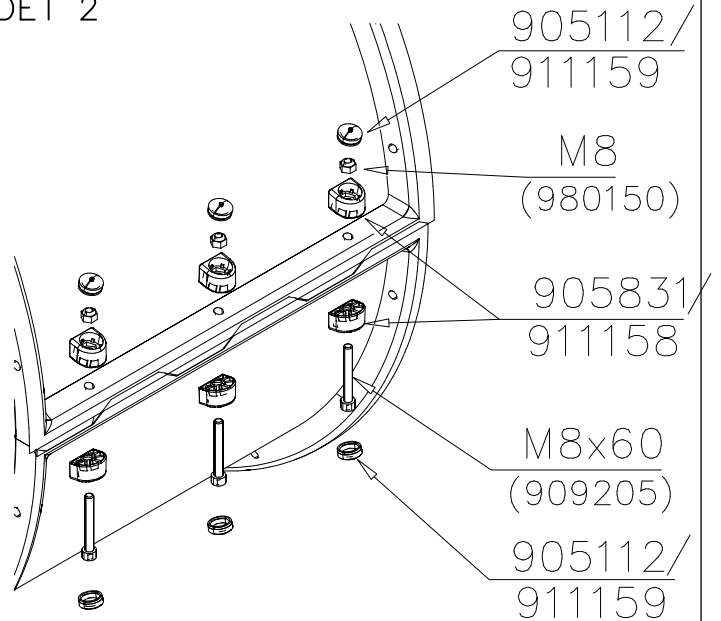

DET 3

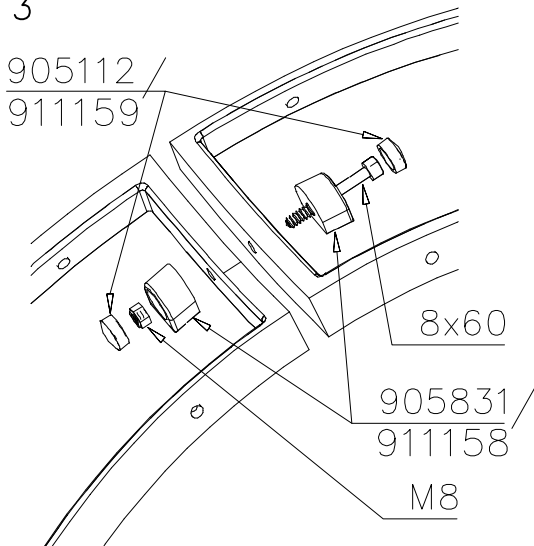

DET 4

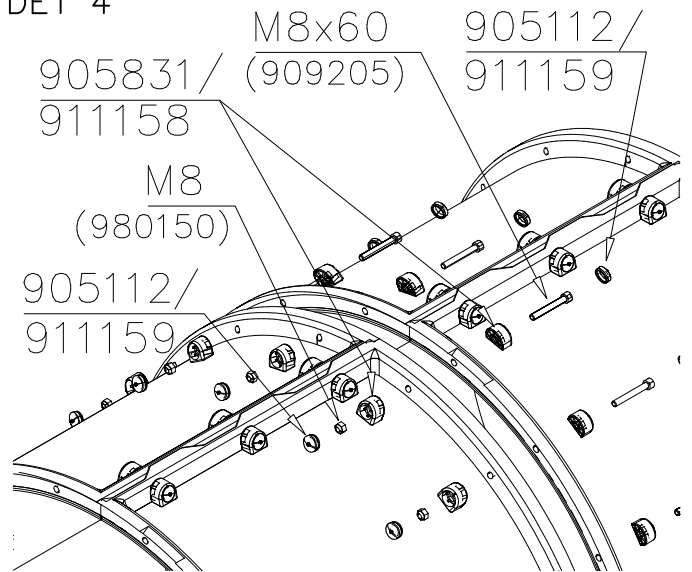

DET 5

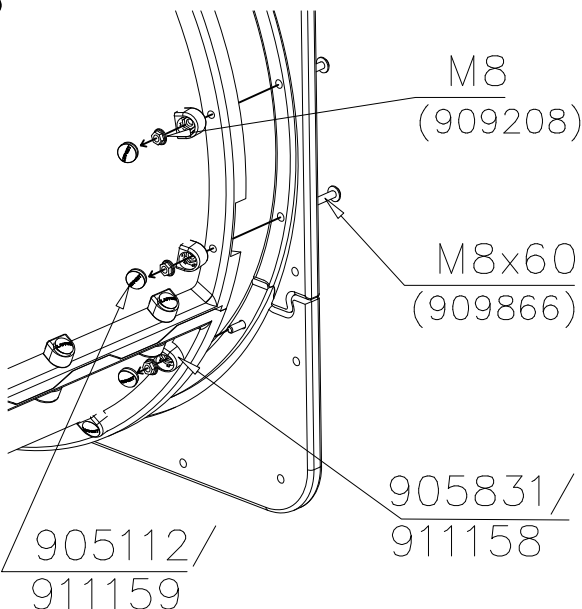

DET 6

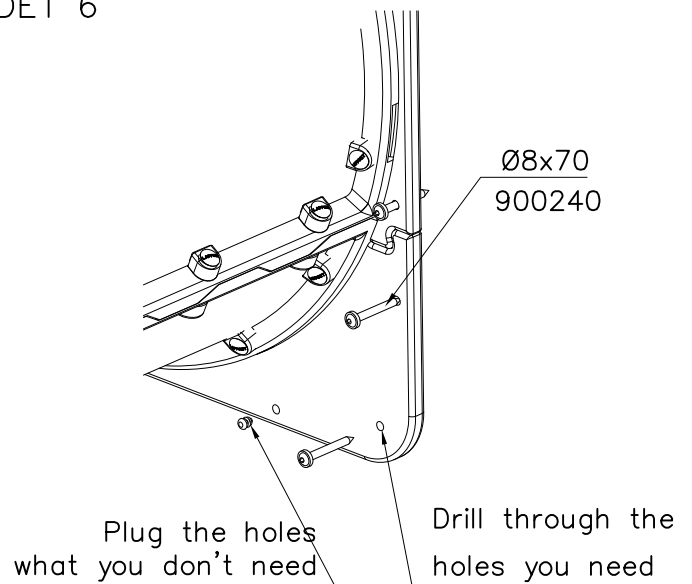

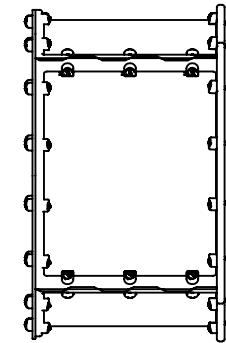
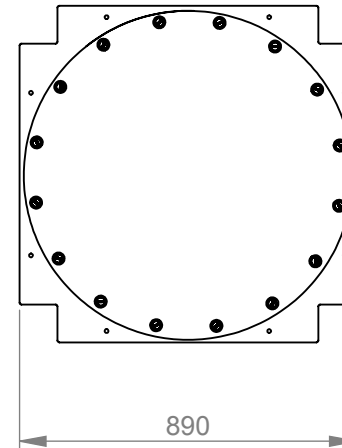
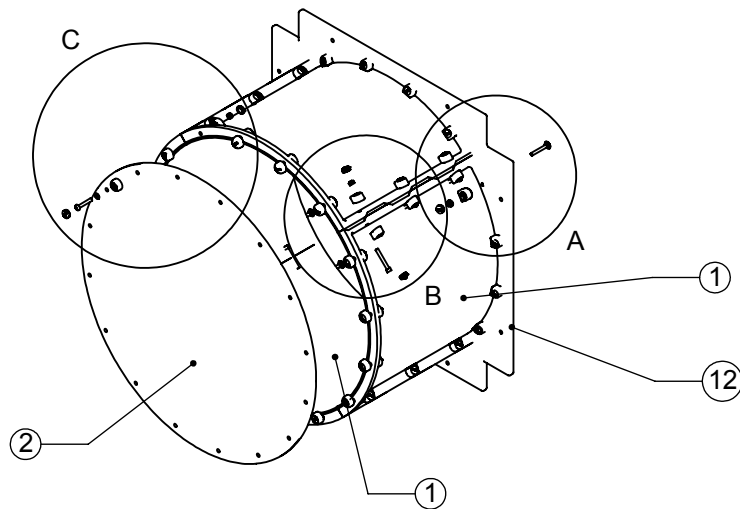

DETAIL A 1 : 10

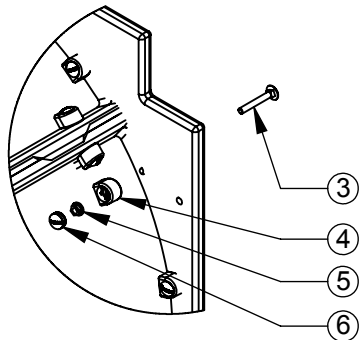

DETAIL B 1 : 10

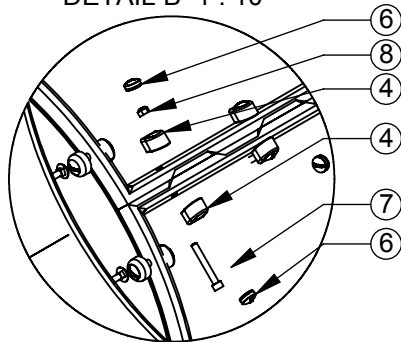

DETAIL C 1 : 10

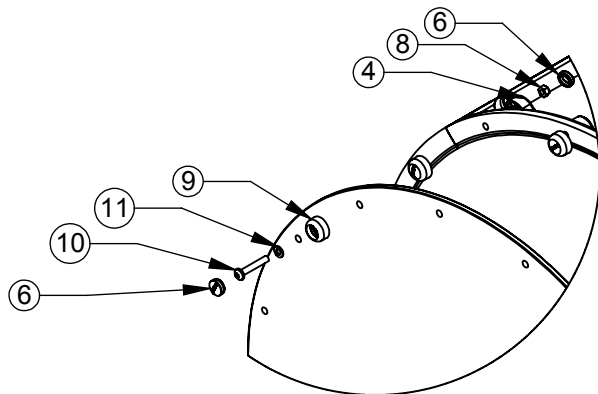

part osa	code nimike	item description nimikkeen kuvaus	dimension koko	pcs kpl	amount määrä	material / note raaka-aine / lisätieto
12	P13018	LIGHTHOUSE BEAM PLATE	20x890x890	1		LAMINATE
11	909256	WASHER	Ø16/8.4x1.6	16		A2 (ST. STEEL)
10	900498	ALLEN SCREW	M8x50	16		A2 (ST. STEEL)
9	905083	PLASTIC WASHER	Ø32	16		PPC BOREALIS BC 650 MO
8	980160	NUT	M8	28		DIN 985 A2
7	909205	ALLEN SCREW	M8x60	12		
6	905112	PLASTIC CAP	Ø22	72		PPC BOREALIS BC 650 MO
5	909208	NUT	M8	16		DIN 6923-8 RIHLATTU
4	905831	PLASTIC WASHER	Ø32x19	56		PBT + 30% GF
3	909119	CARRIAGE BOLT	M8x60	16		DIN 603 ZNK 4,6
2	PM0265	PELASTUSKAPSELIN IKKUNA		1		AKRYYLI, KIRKAS
1	905829	TUBE MODULE	149x516x616	4		PLASTIC, POLYCARPONATE

description
kuvaus

massa
massa

amount
määrä

phase
tila

LIGHTHOUSE BEAM
CLEAR-704

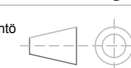

25.89 kg

Production Drawing

item nr
nimike nro

A10320









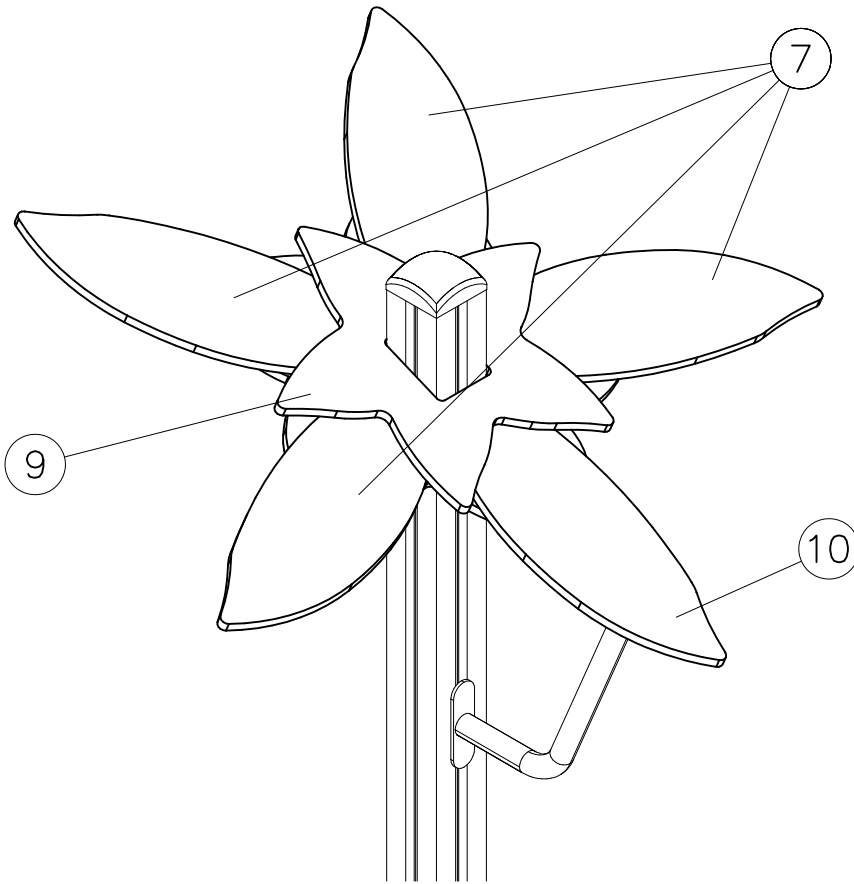

TEL +358 (0) 207 750 100
FAX +358 (0) 207 750 101

PL 8146
SF-96101 ROVANIEMI

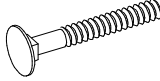
www.lappset.com

revision revisio nro	arkki size	tolerances yleistoleranssi
1	A4	
scale suhde	page sivu	date päiväys
1:20	1/1	24.09.18
	check tark.	22.10.18
		name nimi
		JSU
		JSU

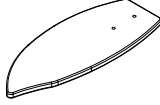
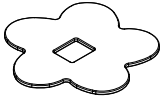

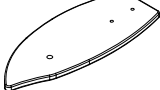
① 905083	PCS	② 905112	PCS
	10		10
Ø32		Ø22	
③ 909101	PCS	④ 909203	PCS
	10		2
M8x45		M8x75	
⑤ 980150	PCS	⑥ 980151	PCS
	10		10
M8		Ø16/8.4	
⑦ PG0899	PCS	⑧ PG0900	PCS
	4		1
⑨ PH0297	PCS	⑩ PM0252	PCS
	1		1
	PCS		PCS
	PCS		PCS
	PCS		PCS

DET 3

DET 1

DET 2,4

901800

DET 1

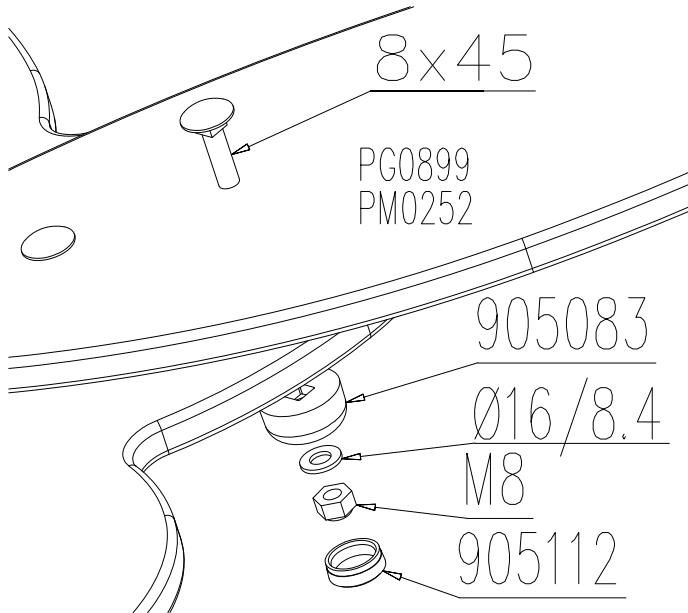

DET 2

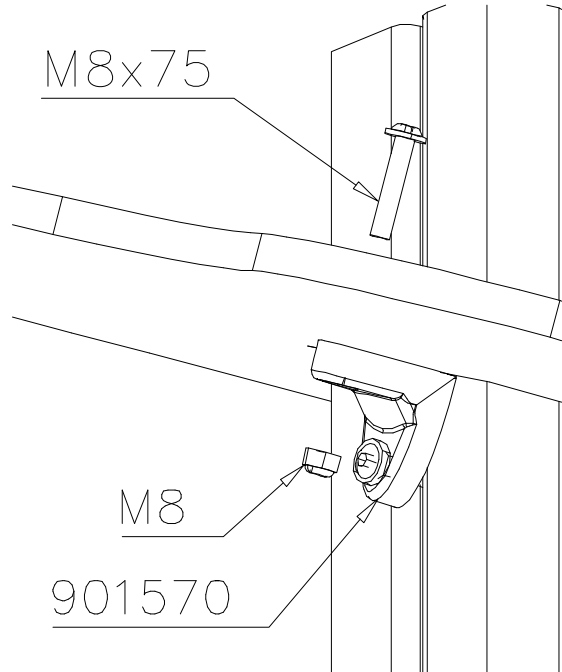

DET 3

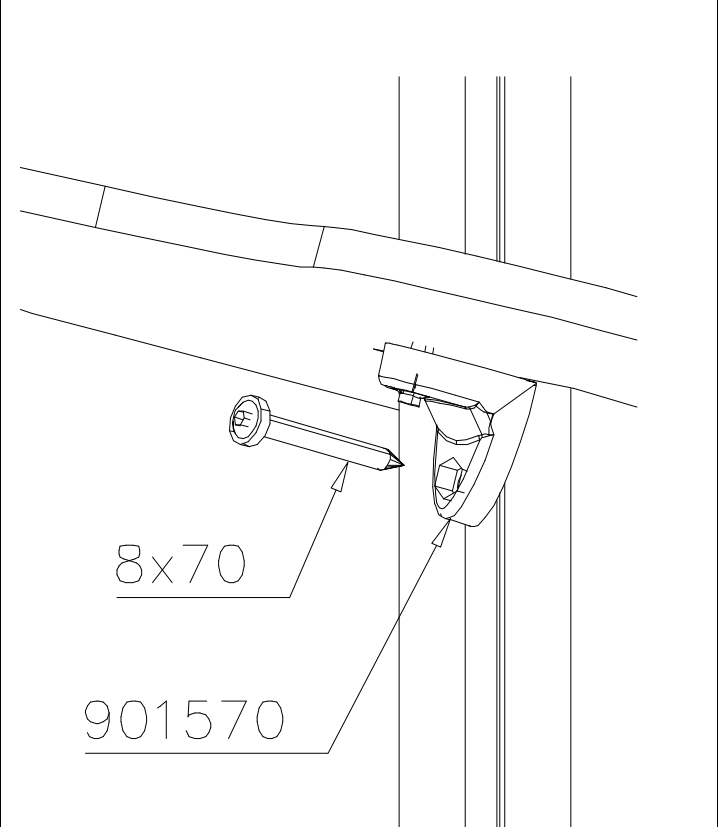
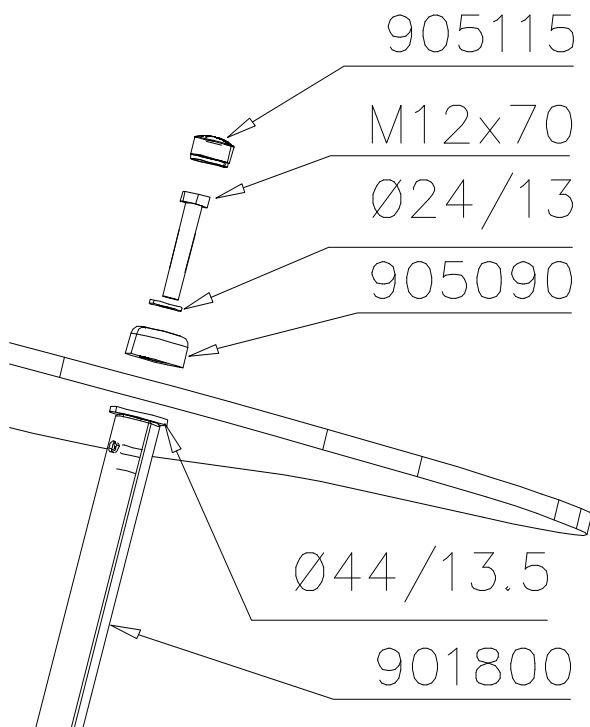

LAPPSET®
DEEP FOUNDATION

FOOT

DATE: 13.3.2014

4A



LAPPSET® BETON FOUNDATION

FOOT

DATE: 27.10.2015

1(1)

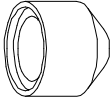
② 905104	PCS		PCS
	4		
			
	M10		
	PCS		PCS



905104

LAPPSET® DEEP FOUNDATION

FOOT

DATE: 15.5.2018

1(1)



① 909511	PCS	② 909519	PCS
	1		1
90x90x650		50x380x380	

③ 909637	PCS	④ 909638	PCS
	4		8
M10		Ø20/10.5	

⑤ 909639	PCS	⑥ 905104	PCS
	4		4
M10x25		M10	

OPTION FOOT

① 911155	PCS		PCS
	1		
90x90x650			

LAPPSET

DEEP FOUNDATION

SLIDE WOOD

DATE: 22.5.2015

1(1)





SLIDE OPTIONS

<p>706450 +1470</p> 	<p>706450-602 DARK BROWN 706450-603 LIGHT BROWN 706450-604 LIGHT GRAY</p>	
<p>706452 +870</p> 	<p>706452-602 DARK BROWN 706452-603 LIGHT BROWN 706452-604 LIGHT GRAY</p>	

WALL OPTIONS

<p>706371</p> 	<p>706371-701 BLUE 706371-702 YELLOW 706371-703 LIME 706371-704 DRARK GRAY 706371-705 LIGHT GRAY 706371-706 RED</p>	<p>706371-707 GREEN 706371-708 FUXIA</p>
---	--	---

LAPPSET

80M

SLIDE WOOD

DATE: 3.11.2017

2(5)

○ SLIDE	PCS	○ SLIDE	PCS	○ 706371	PCS	○ 706505	PCS	○ 901868	PCS	① 903093	PCS
	1		1		2		2		1		2
+1470		+870		15x345x750		35x70x730		Ø34x598		Ø8x90	
② 909876	PCS	③ 980100	PCS	④ 980128	PCS	⑤ 999561	PCS				
	2		12		11		1				
M8x40		Ø5x60		Ø7x40		10g					



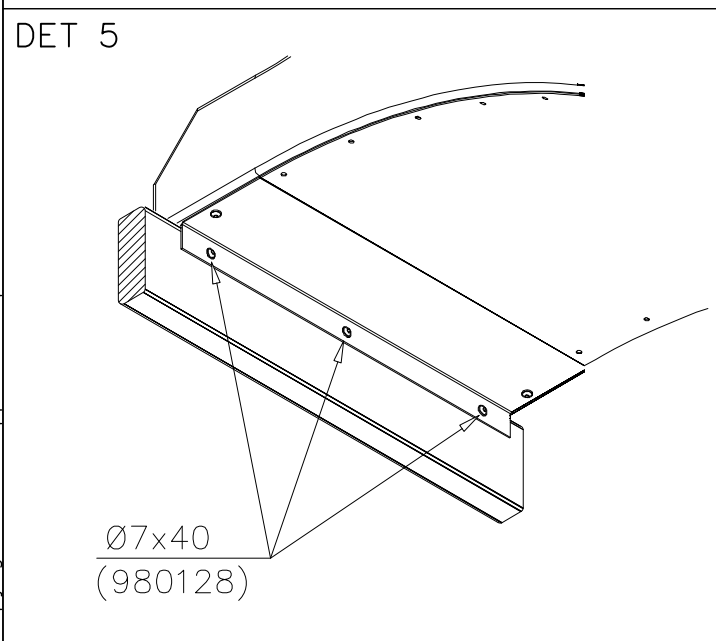
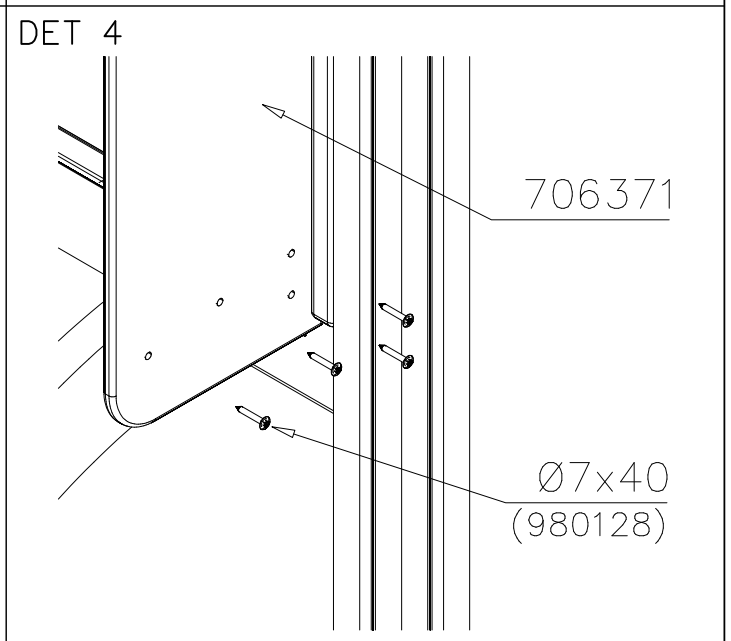
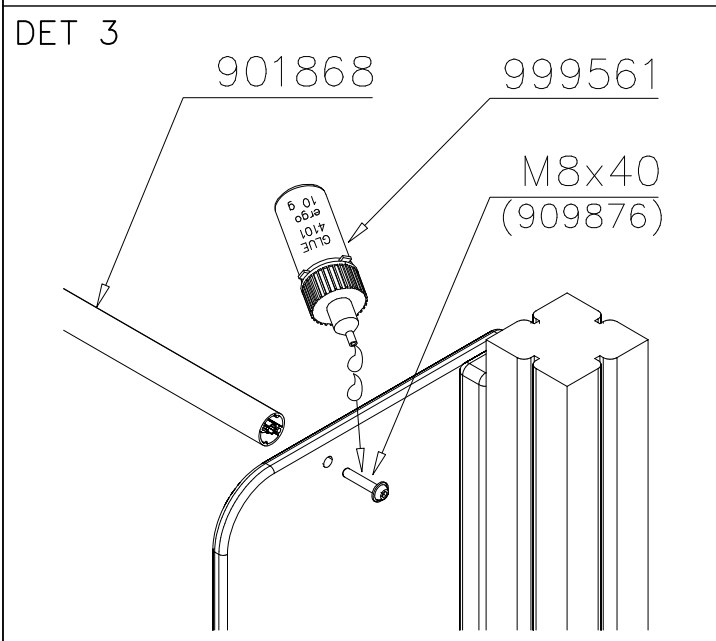
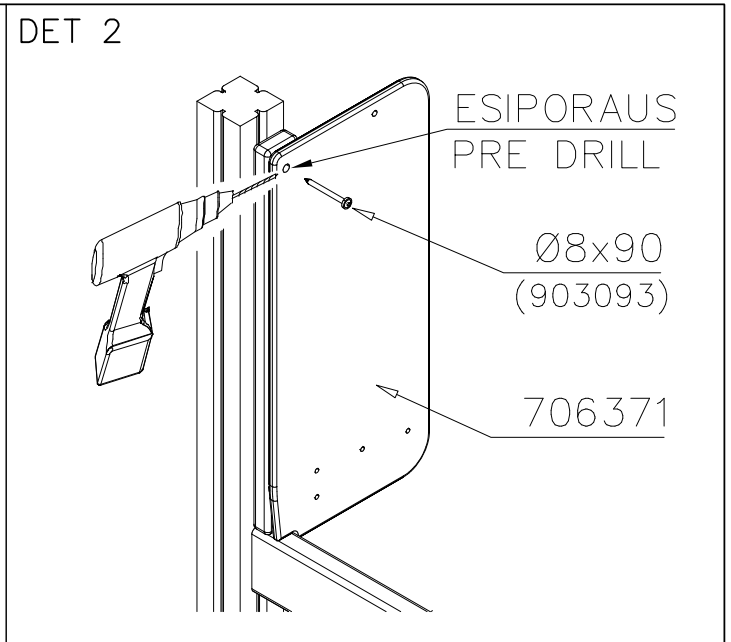
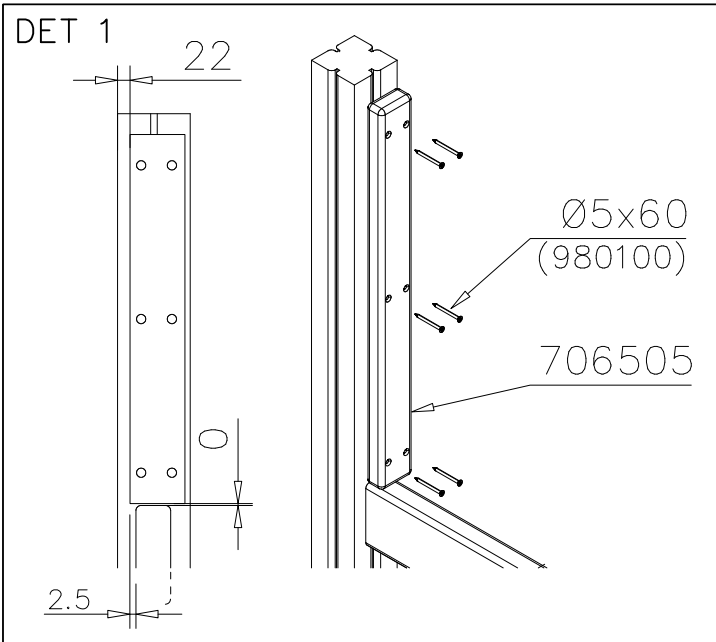



LAPPSET

DEEP FOUNDATION

SLIDE WOOD

DATE: 3.11.2017

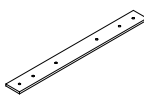
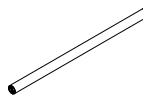
4(5)

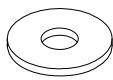
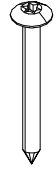
○ 707133	PCS	○ 901868	PCS	○ 901879	PCS	⑥ 909210	PCS	⑦ 905051	PCS	⑧ 980128	PCS
	1		2		2		4		4		6
10x80x745		Ø30x598				M8x40		Ø24/8.4		Ø7x40	



DET 6

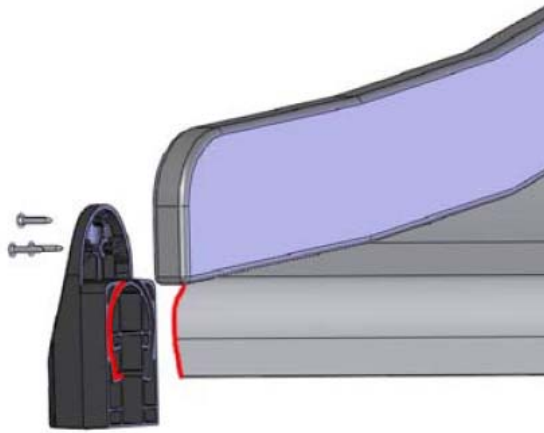

Insert sheet metal IN to the plastic cover.

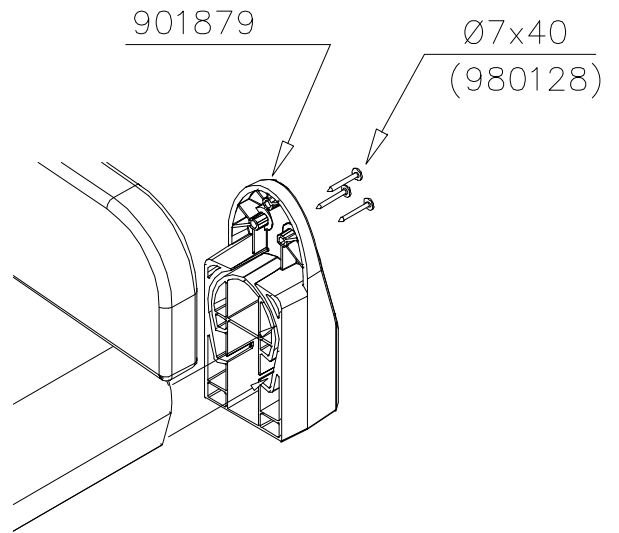

DET 7

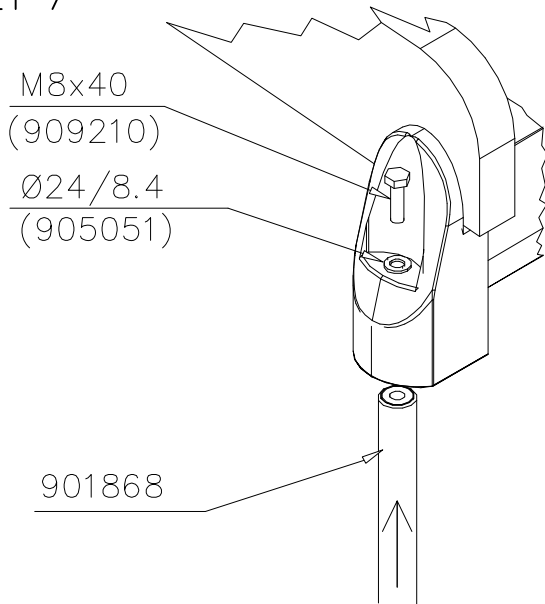

DET 8

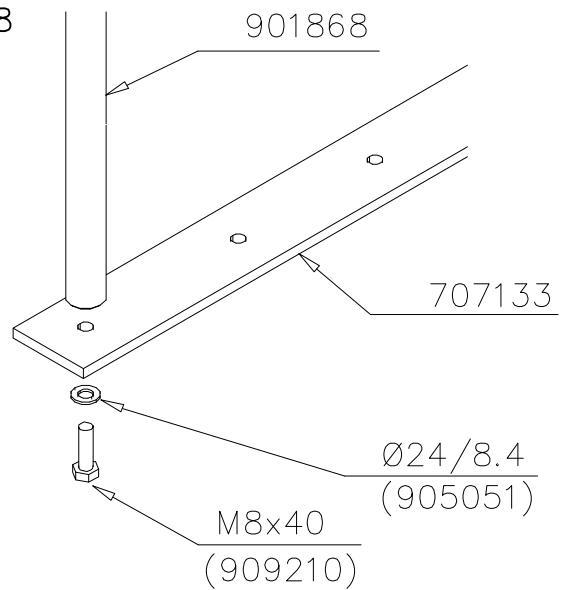



① 903176	PCS	② 909850	PCS
	4		4
		M8x25	
③ 909256	PCS	④ 909633	PCS
	8		4
Ø16/8.4x1.6		M8	
⑤ 980123	PCS		PCS
	4		
Ø7x60			
	PCS		PCS







① 008986	PCS	② 706443	PCS
	1		2
750x750		32x45x702	
③ 900240	PCS	④ 980101	PCS
	6		8
Ø8x70		Ø4.5x70	
	PCS		PCS
	PCS		PCS
	PCS		PCS

DET 1

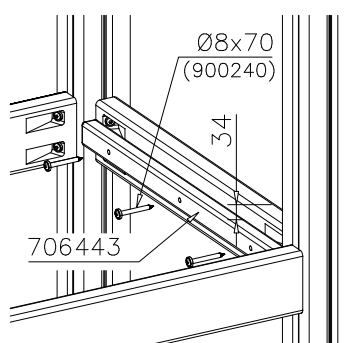

DET 2

Naulanauha kannatinlistan puolelle.
Nail list to the bottom.

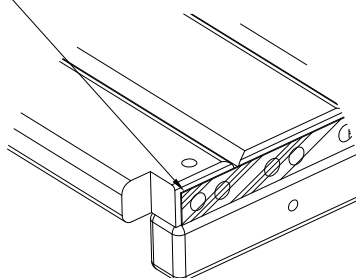

DET 3

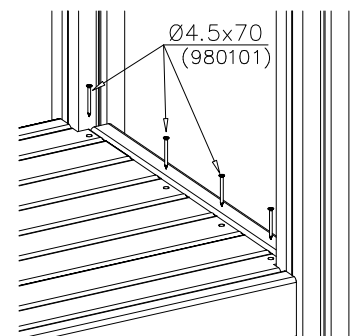

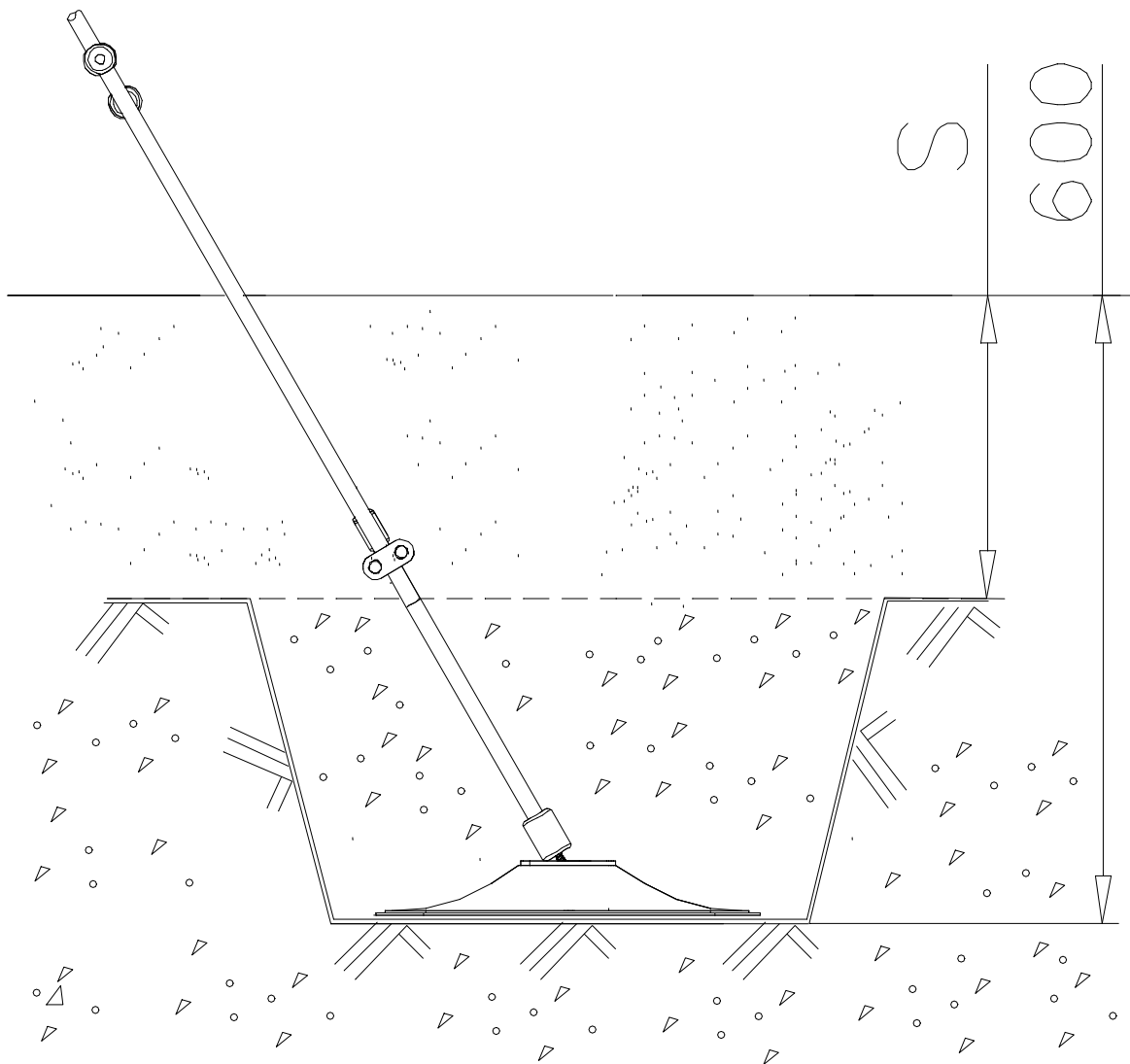
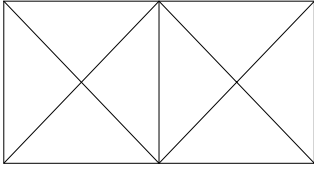



LAPPSET® DEEP FOUNDATION

ROPE LADDER

DATE: 30.6.2016

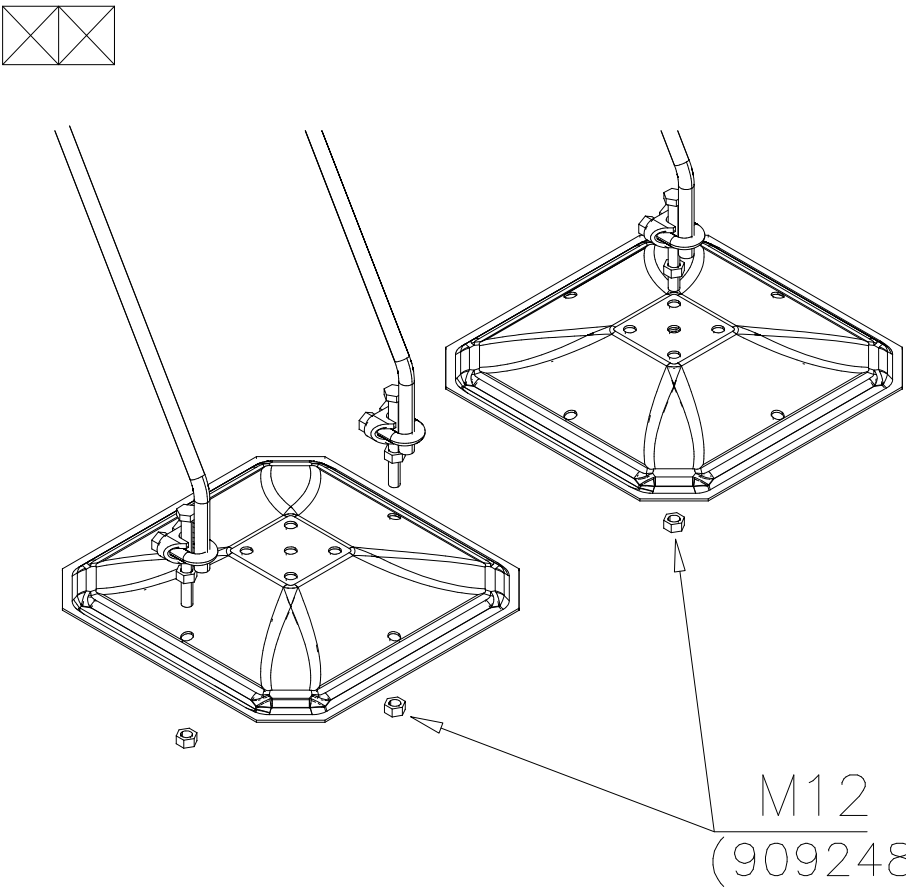
1(1)

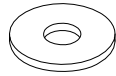
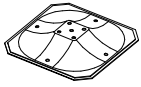
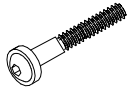

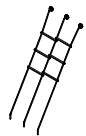
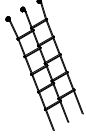
①	905051	PCS	②	909519	PCS
		2			2
					
	Ø24/8.4		50x380x380		
③	909867	PCS	④	909633	PCS
		2			2
					
	M8x70		M8		
⑤	903093	PCS			PCS
		4			
					
	Ø8x90				
○	706462	PCS	○	707393	PCS
		1			1
					
	+1470		+1970		

M12
(909248)

ROPE LADDER COLOR OPTIONS

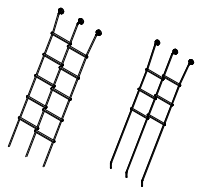

xxxxxx-301	BLUE
xxxxxx-302	RED
xxxxxx-303	BEIGE
xxxxxx-304	GRAY
xxxxxx-305	BLACK
xxxxxx-306	YELLOW

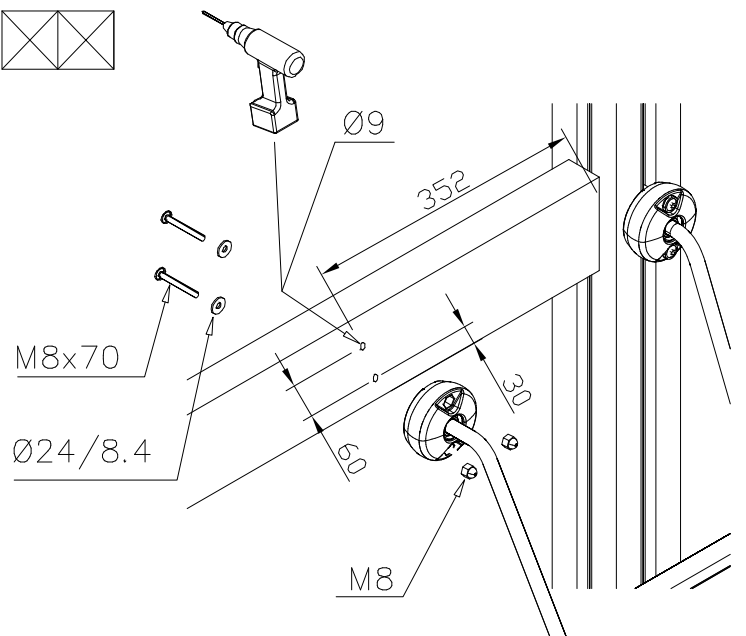
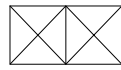
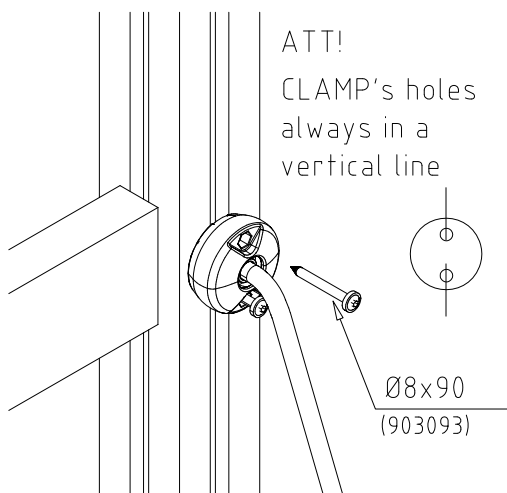
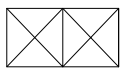





BOOM OPTIONS		
706510	706510-602	DARK BROWN
	706510-603	LIGHT BROWN
	706510-604	LIGHT GRAY
45x120x1030		

DET 1

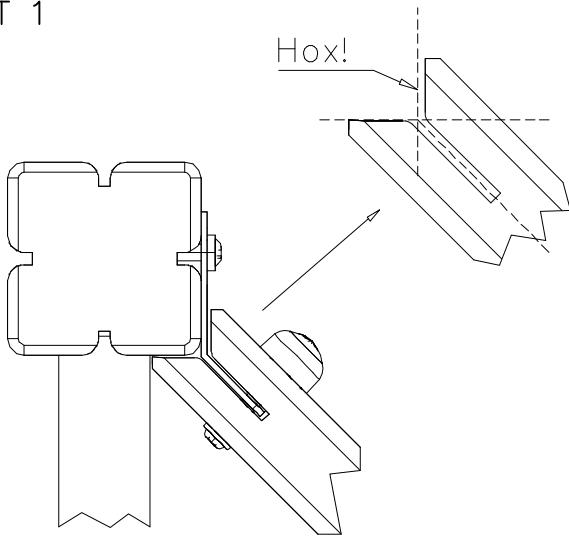





DET 2 M8x60
 (909866)

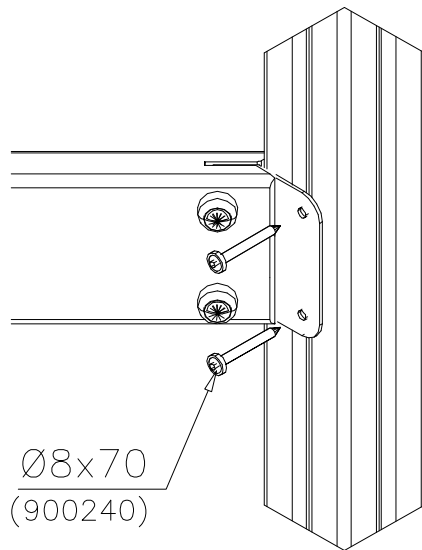

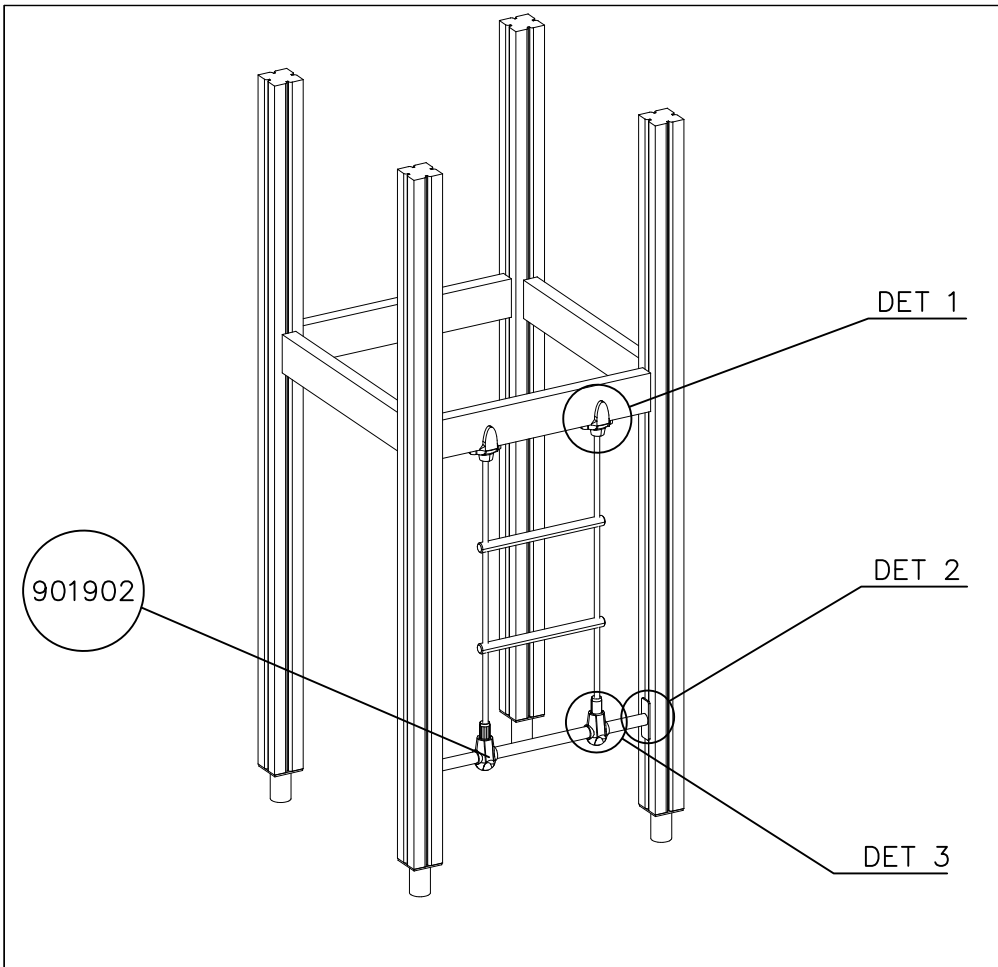
DET 3



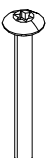
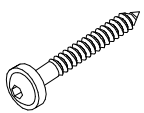
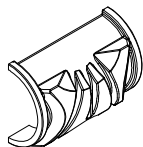

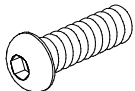
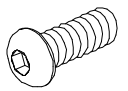
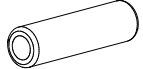
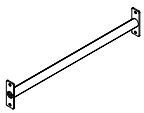
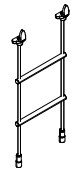
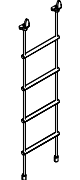
① 901902	PCS 4	② 980128	PCS 2
			
30x61x100		Ø7x40	
③ 980123	PCS 4	④ 900240	PCS 4
			
Ø7x60		Ø8x70	
⑤ 901900	PCS 4	⑥ 909633	PCS 2
			
20.5x36.2x56		M8	
⑦ 909850	PCS 2	⑧ 900342	PCS 4
			
M8x25		M8x16	
⑨ 901182	PCS 2	○ 907694	PCS 1
			
Ø11/M8x40		L 704	
○ 706473	PCS 1	○ 706780	PCS 1
			
+1470		+1970	

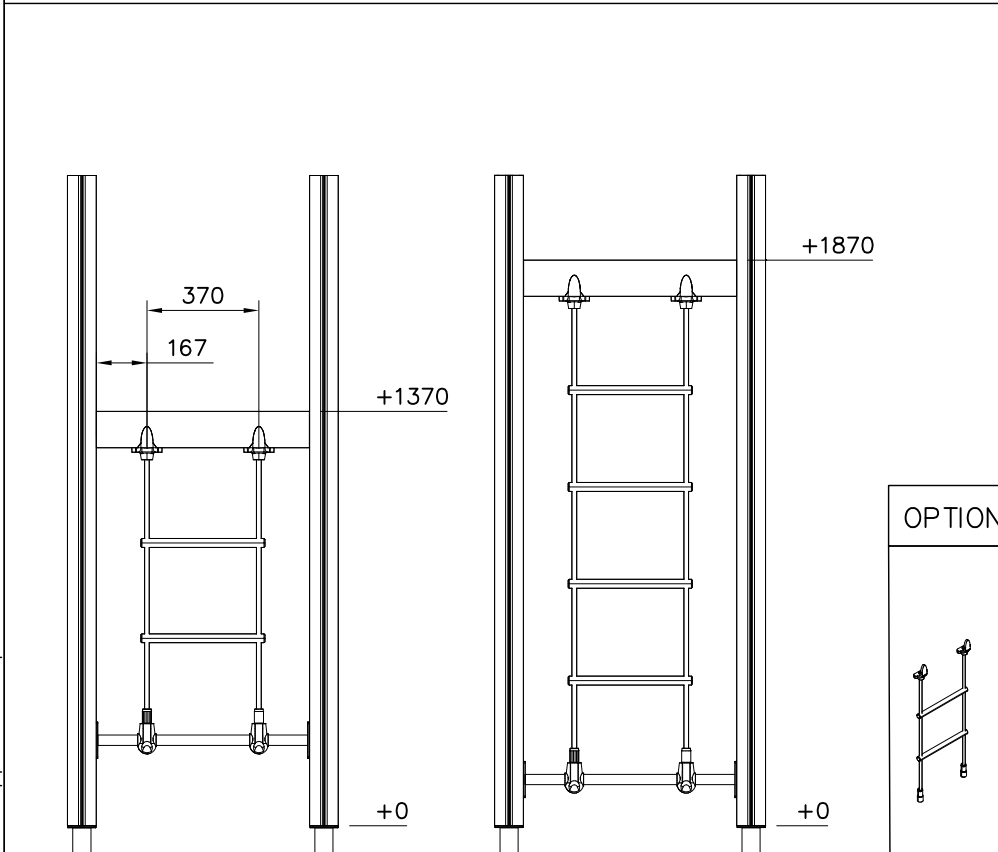

OPTIONS

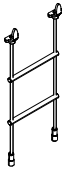
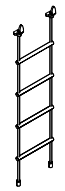
	-301	BLUE
	-302	RED
	-303	BEIGE
	-304	GRAY
	-305	BLACK
	-306	YELLOW

DET 1

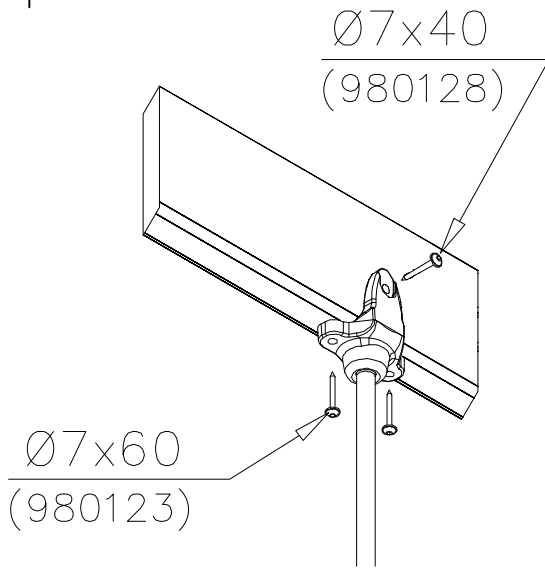

DET 2

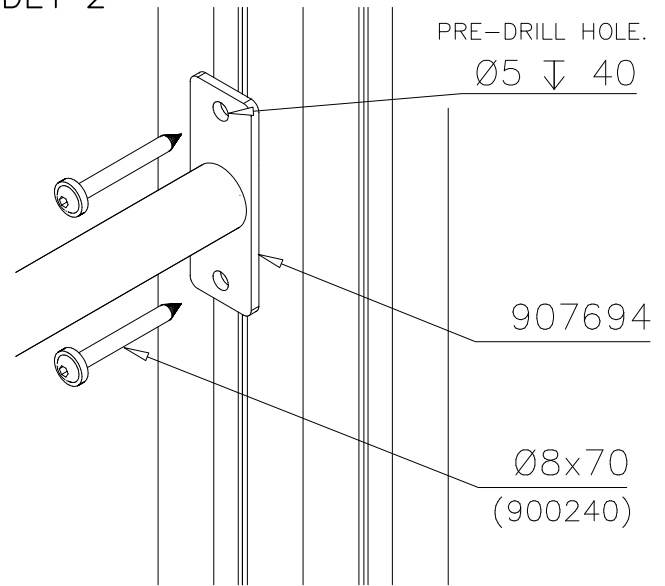

DET 3

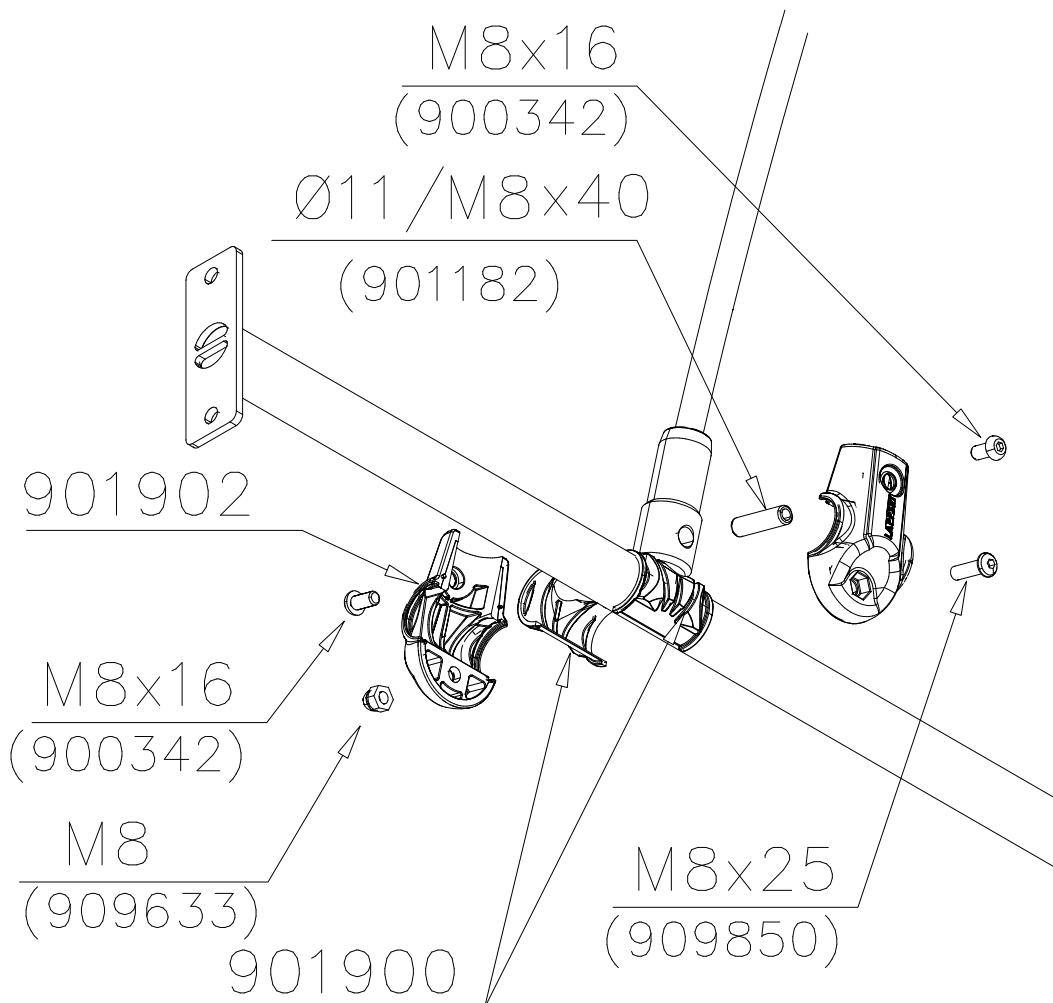

① 903176	PCS	② 909852	PCS
	6		6
		M8x30	
③ 909256	PCS	④ 909633	PCS
	6		6
Ø16/8.4x1.6		M8	
⑤ 980123	PCS		PCS
	6		
Ø7x60			
	PCS		PCS



WALL OPTIONS		
706507	706507-701	BLUE
	706507-702	YELLOW
	706507-703	LIME
	706507-704	DARK GRAY
	706507-705	LIGHT GRAY
	706507-706	RED
	706507-707	GREEN
	706507-708	FUXIA
20x702x1160		

DET 1

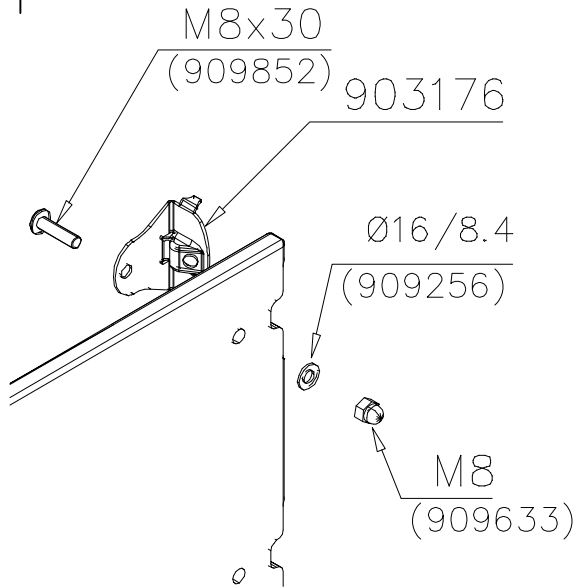

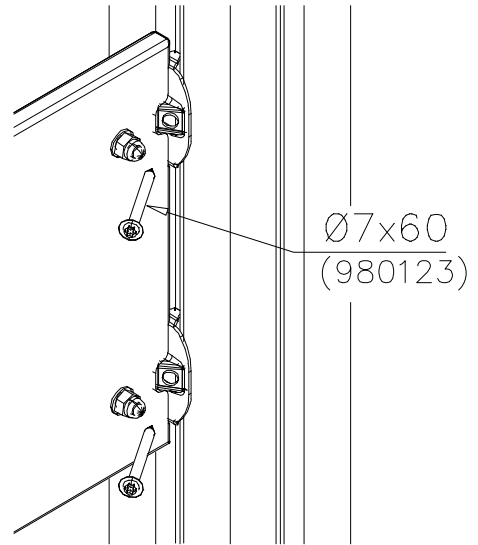

DET 2

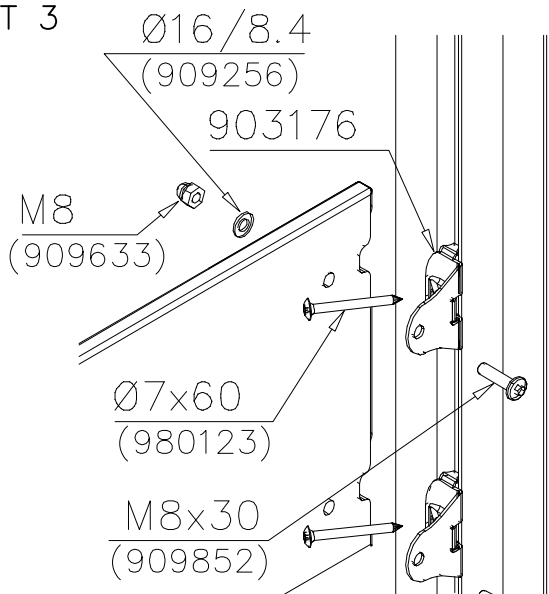

DET 3

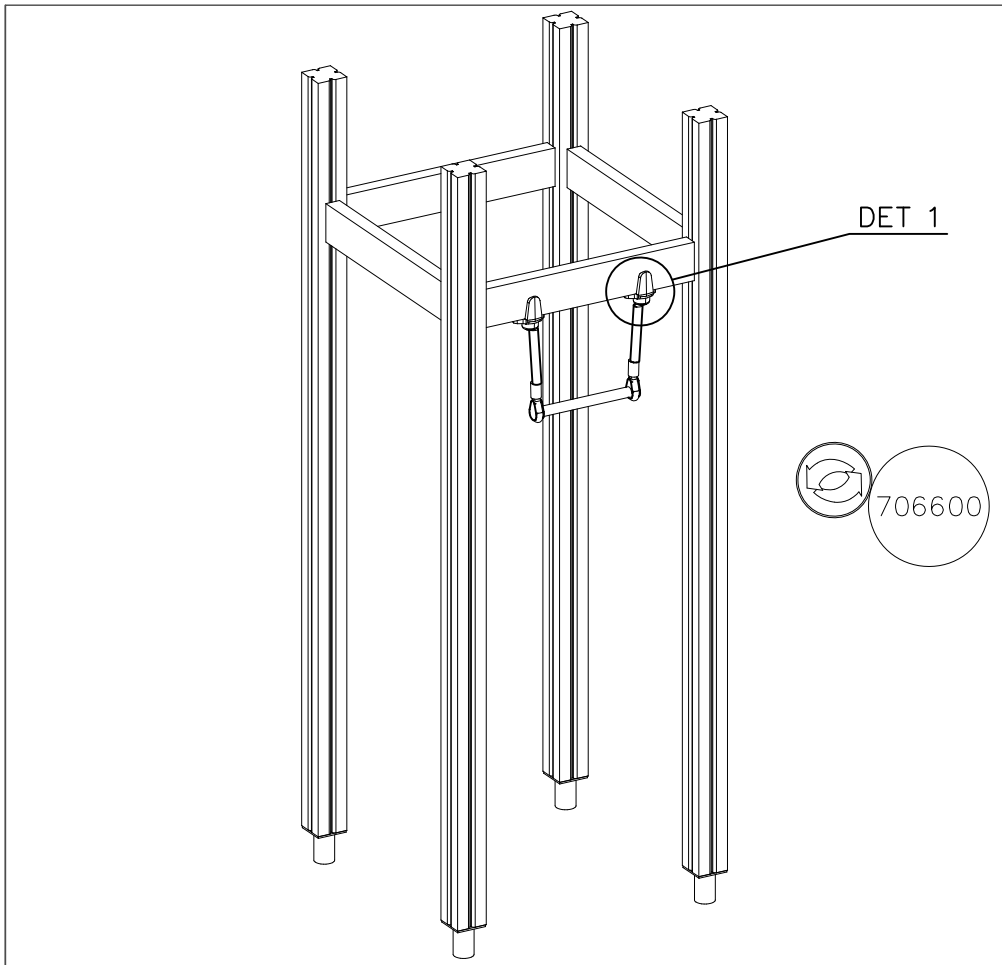

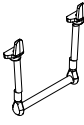

① 706600	PCS	② 980128	PCS
	1		2
		Ø7x40	
③ 980123	PCS		PCS
	4		
		Ø7x60	
	PCS		PCS
	PCS		PCS

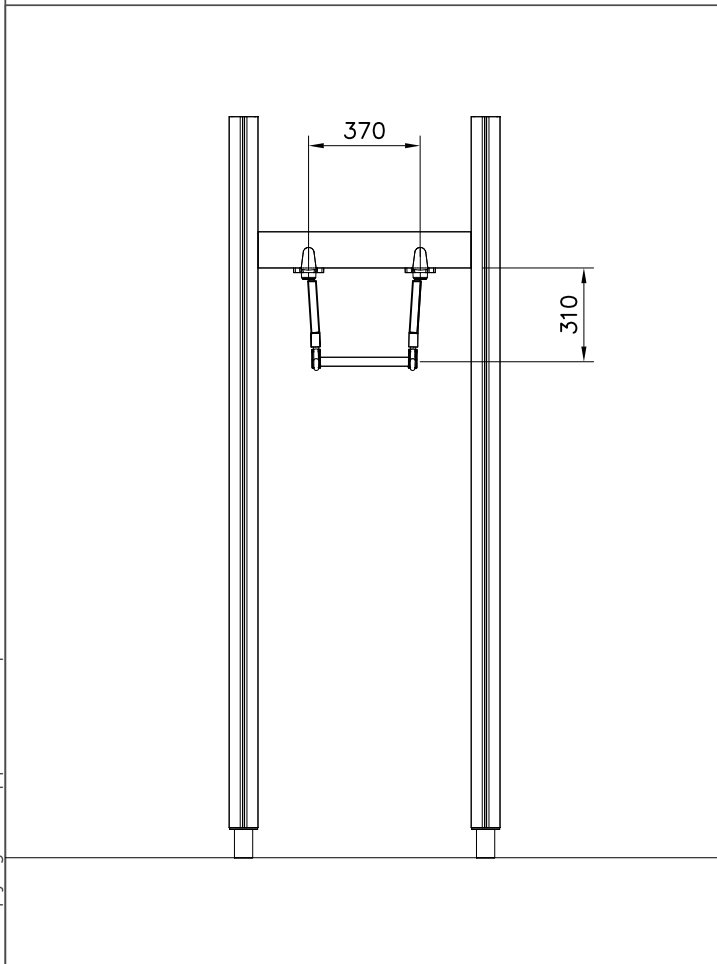

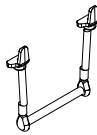
TRAPEZE OPTIONS		
706600	706600-301	BLUE
	706600-302	RED
	706600-303	BEIGE
	706600-304	GRAY
	706600-305	BLACK
	706600-306	YELLOW

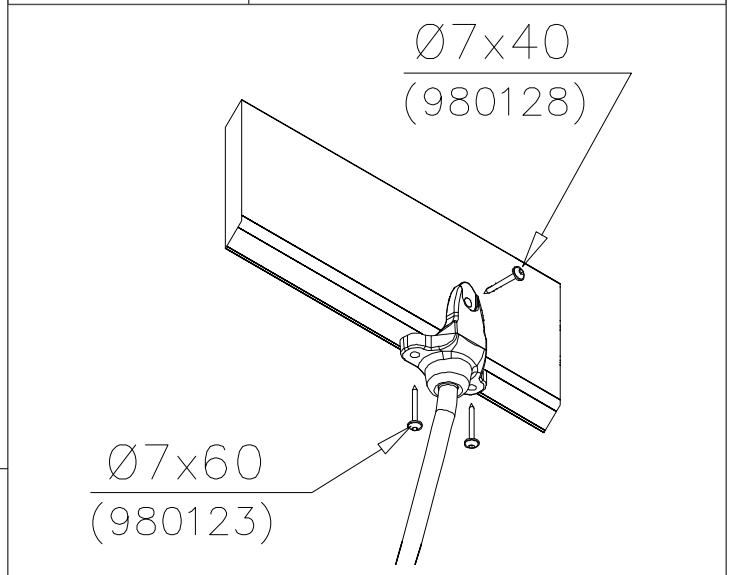

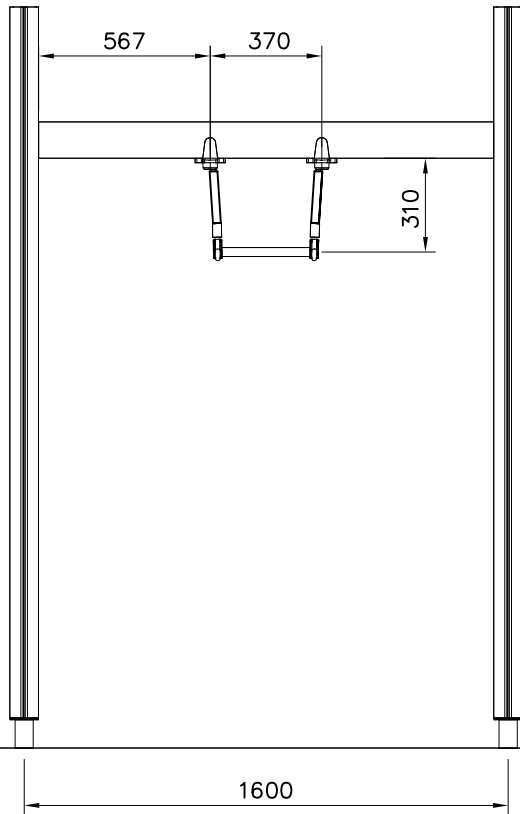
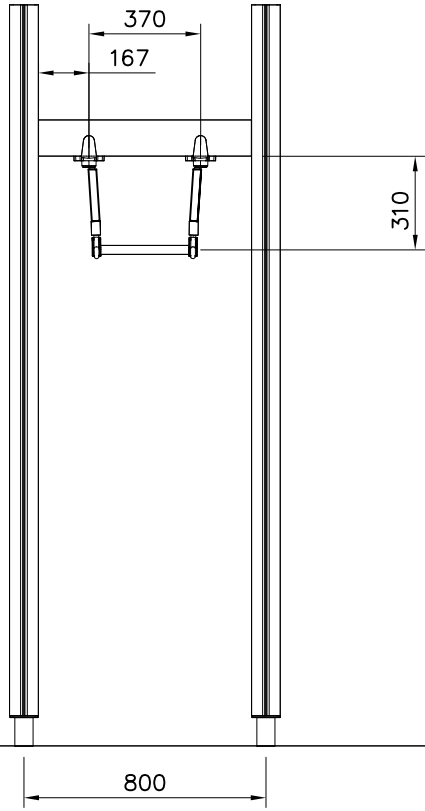

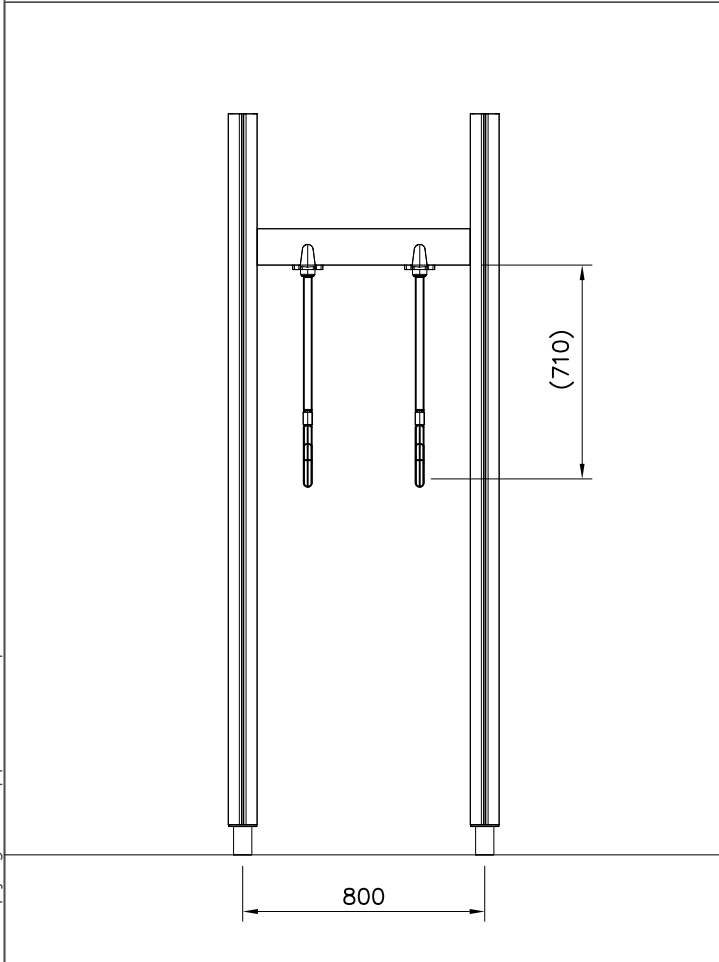
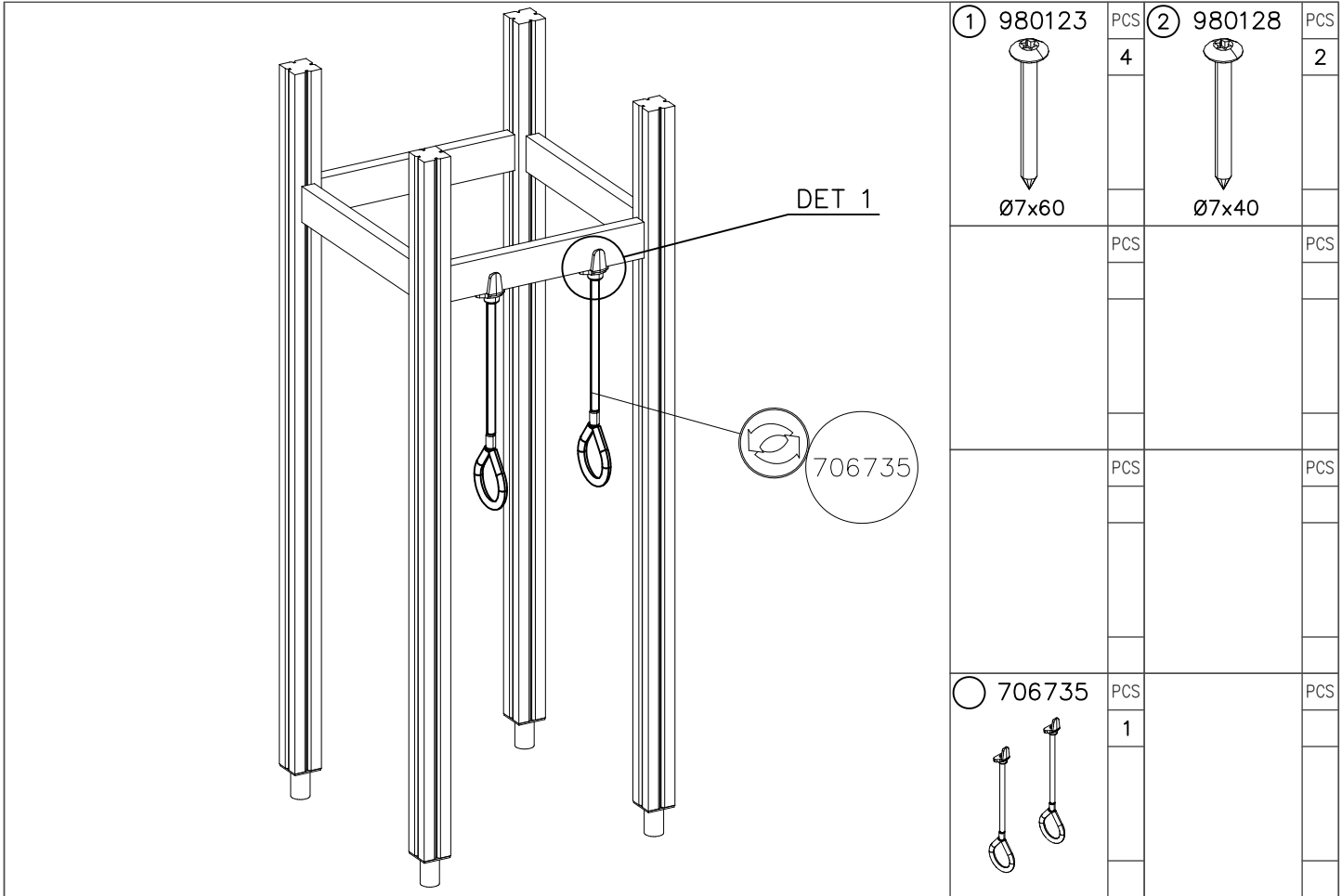

RINGS OPTIONS

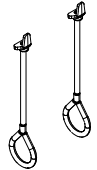
	706735-301	BLUE
	706735-302	RED
	706735-303	BEIGE
	706735-304	GRAY
	706735-305	BLACK
	706735-306	YELLOW

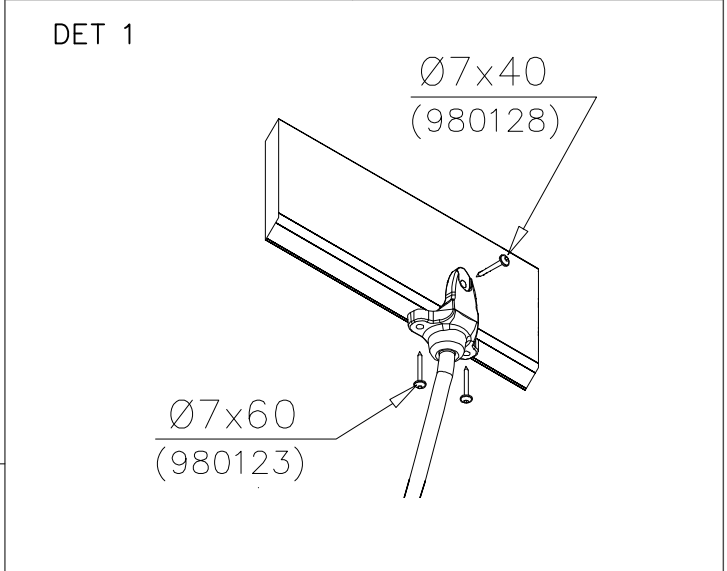

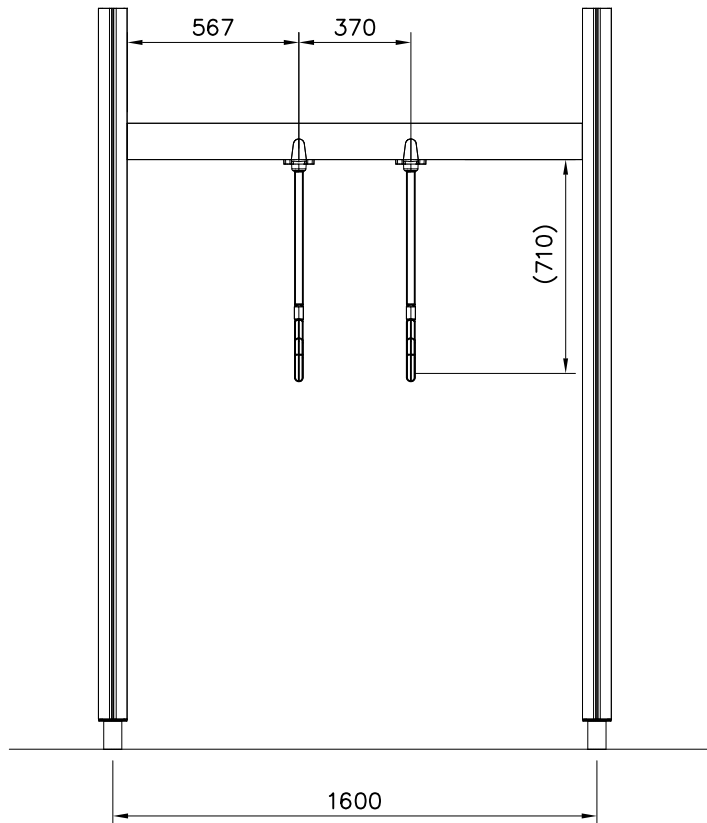
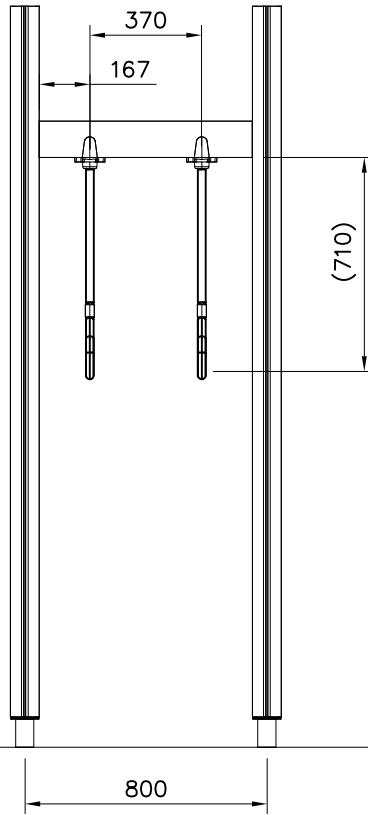

① 706746	PCS	② 909530	PCS
	1		4
45x640x701		55.9x127.5	
③ 900240	PCS	④ 980151	PCS
	4		4
Ø8x70		Ø16/8.4x1.6	
⑤ 905112	PCS		PCS
	4		
Ø22			
	PCS		PCS



WALL OPTIONS		
 706746 45x640x701	706746-605	DARK GRAY
	706746-606	GRAY
	706746-607	RED
	706746-608	BLUE
	706746-609	GREEN
	706746-610	YELLOW
	706746-611	LIME
	706746-612	FUXIA

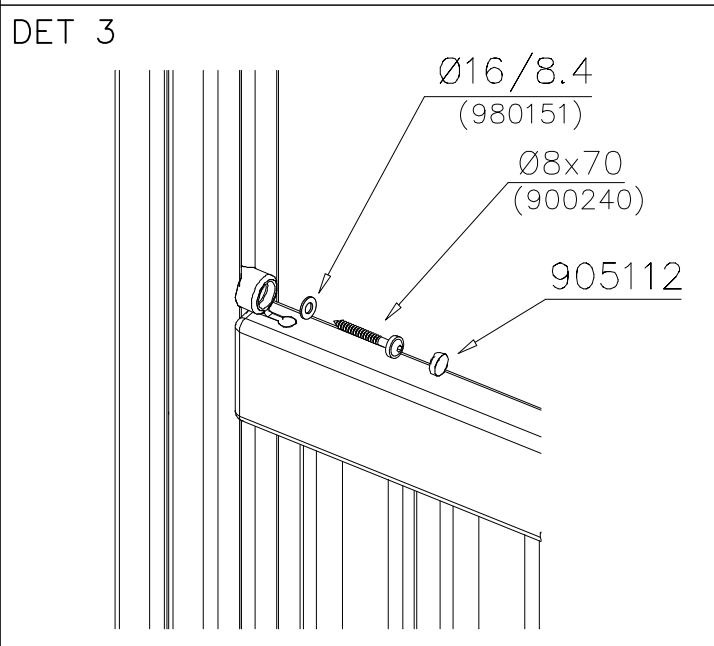
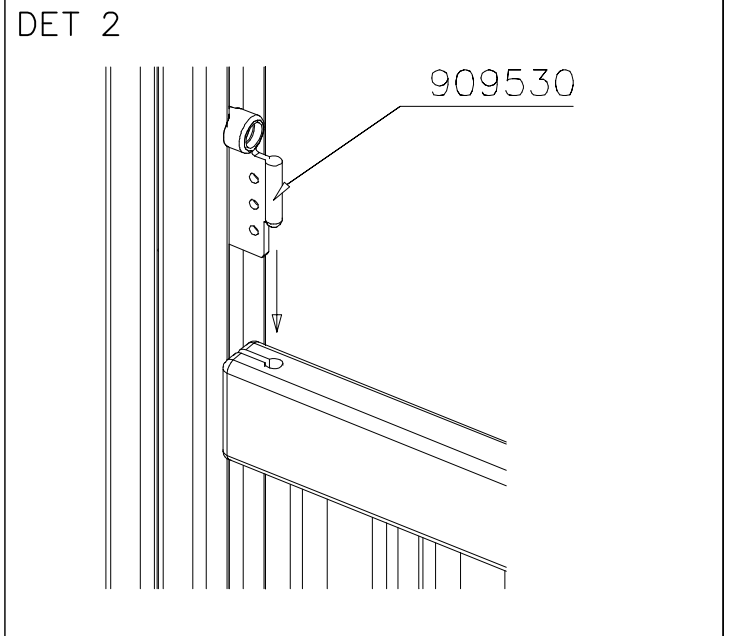
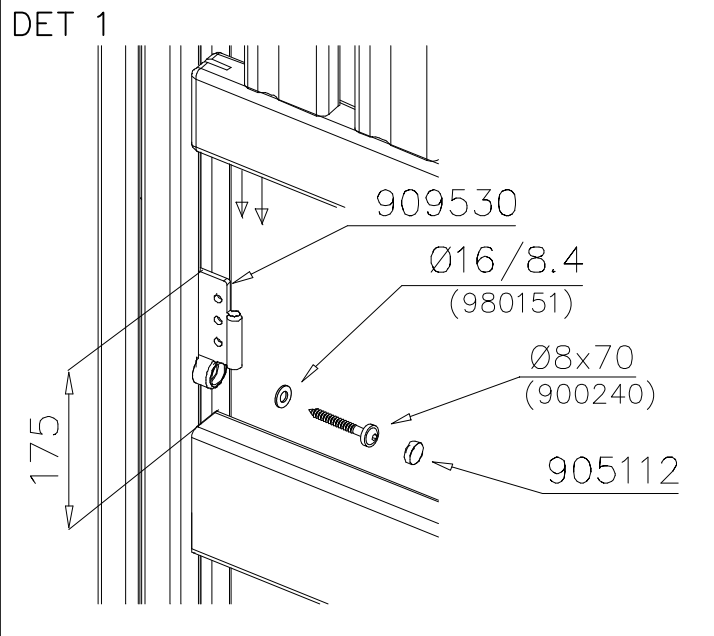

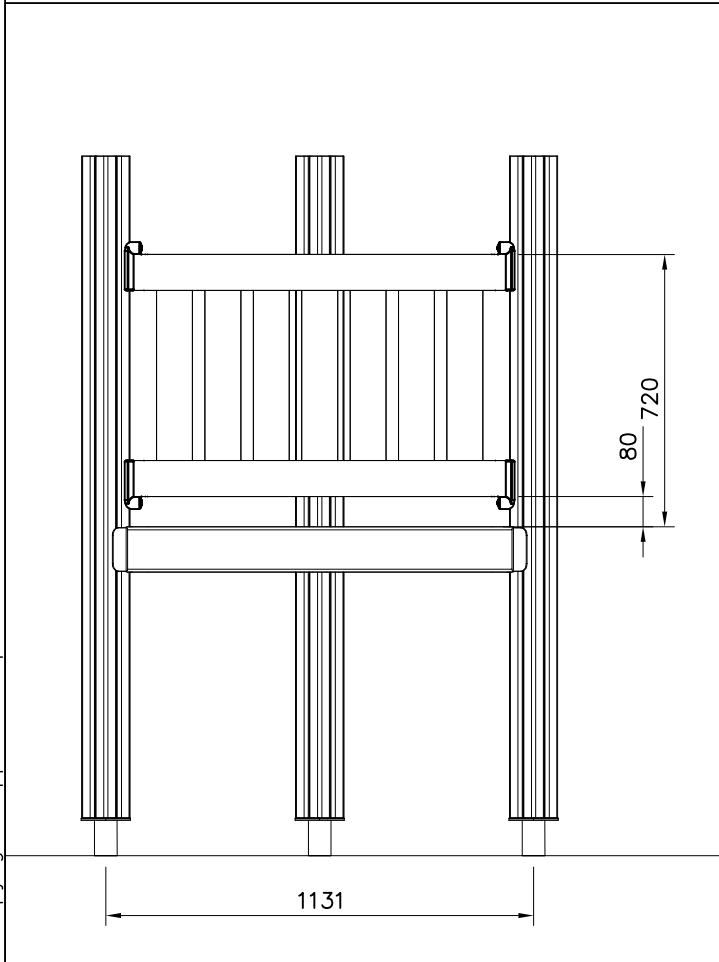
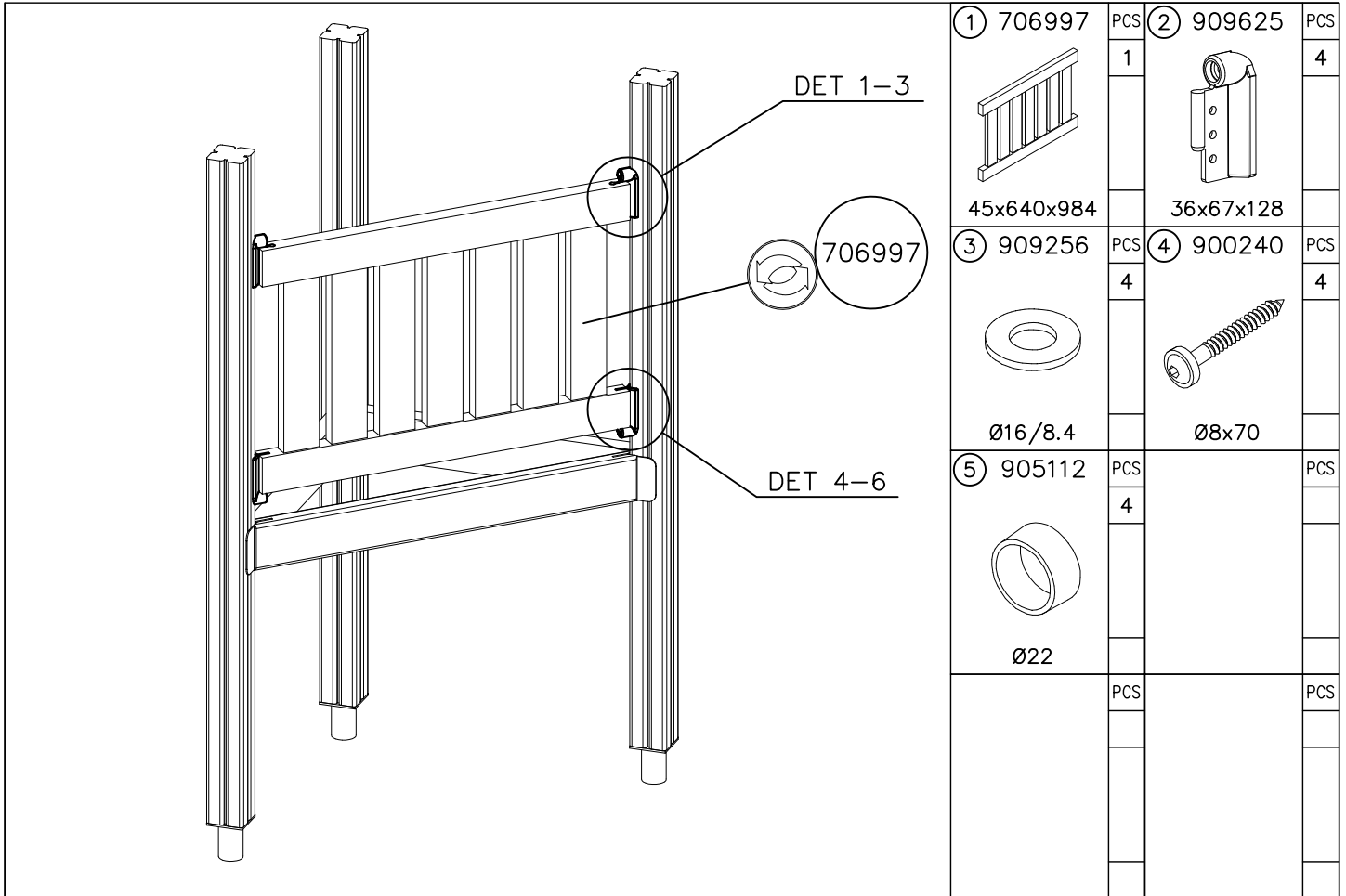

WOODEN WALL OPTIONS

 706997 45x640x984	706997-605	DARK GRAY
	706997-606	GRAY
	706997-607	RED
	706997-608	BLUE
	706997-609	GREEN
	706997-610	YELLOW
	706997-611	LIME
	706997-612	FUXIA

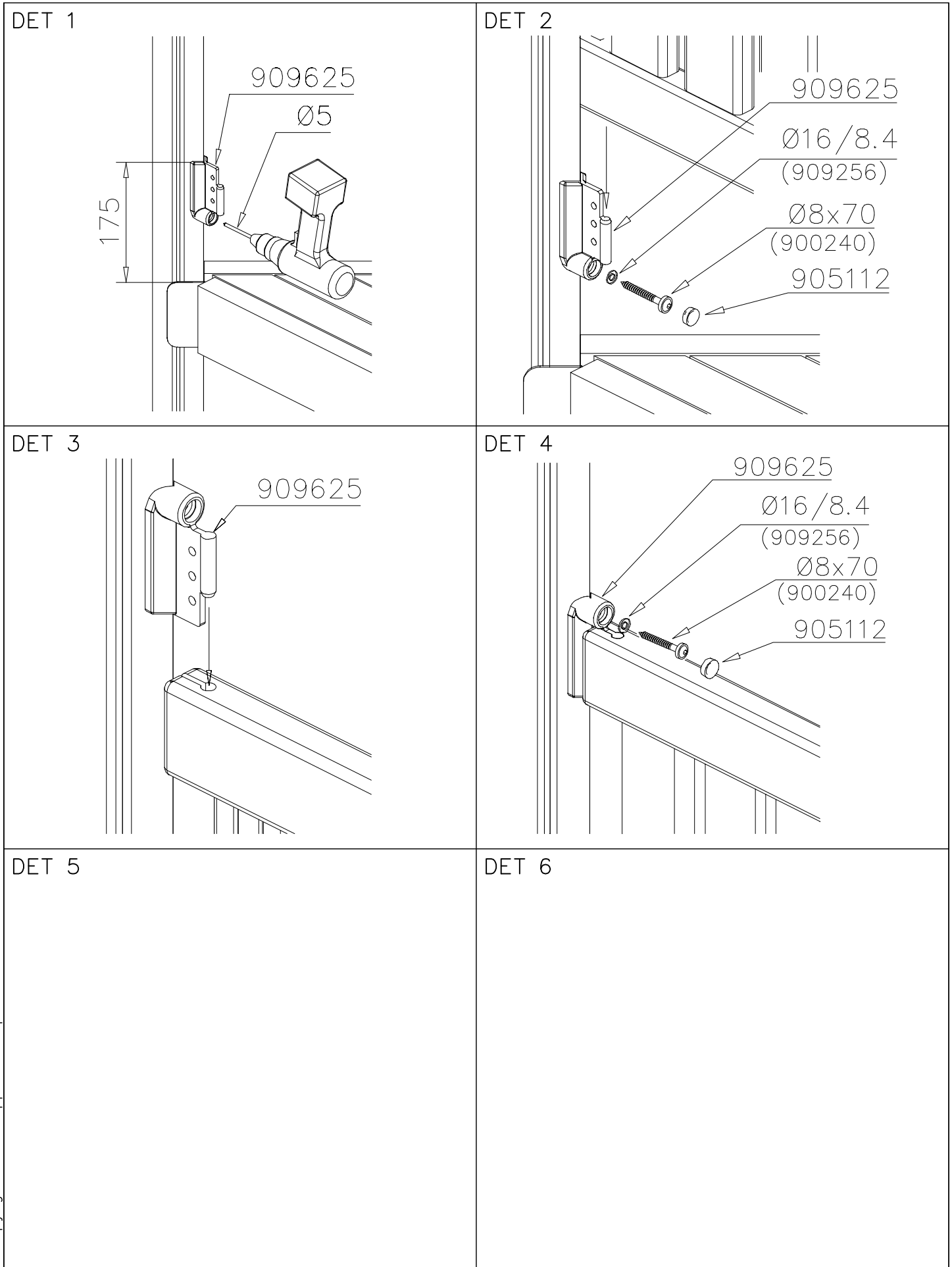

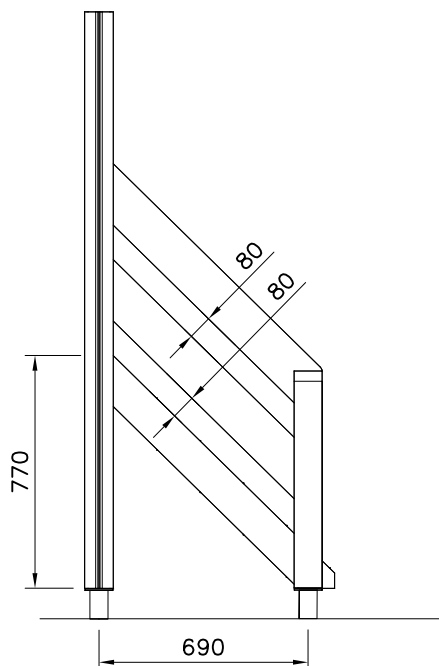
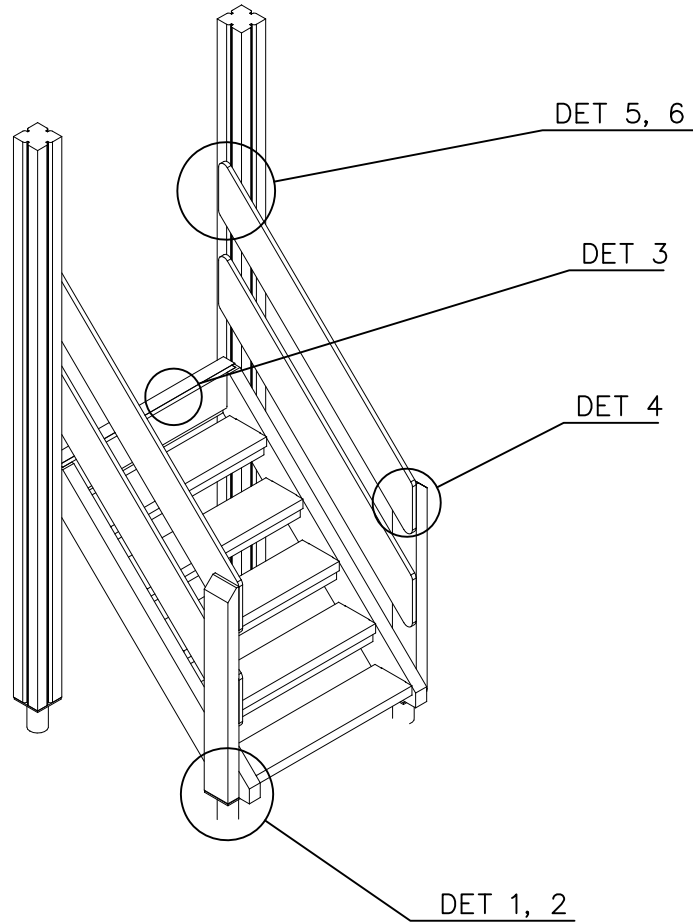

DET 1



DET 2



DET 3

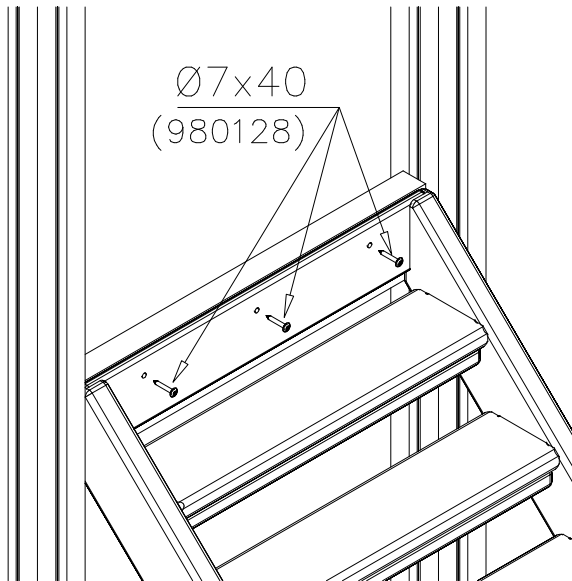

DET 4

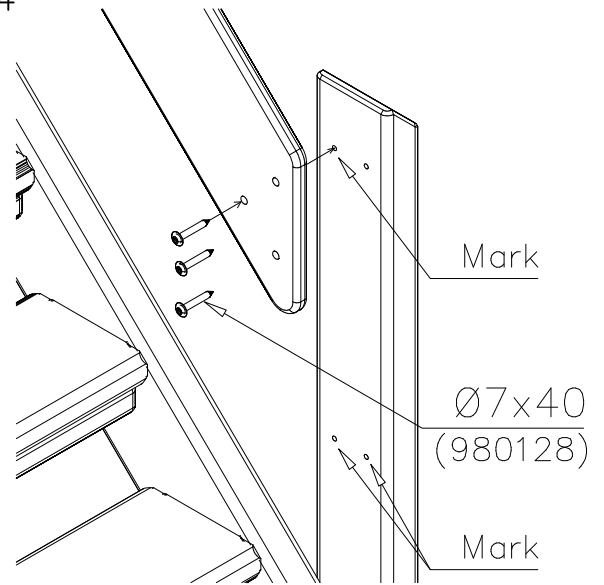

DET 5

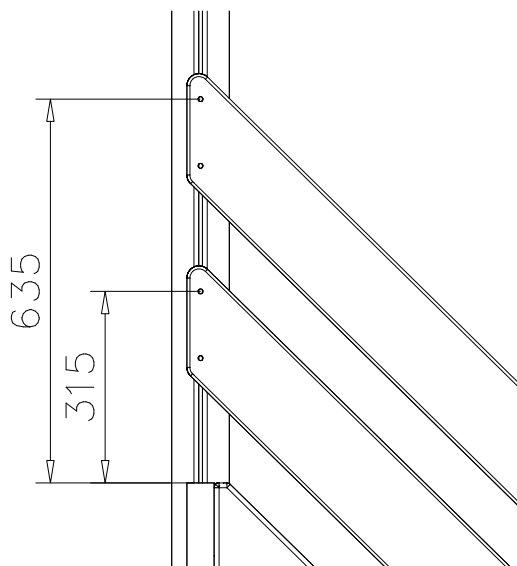

DET 6

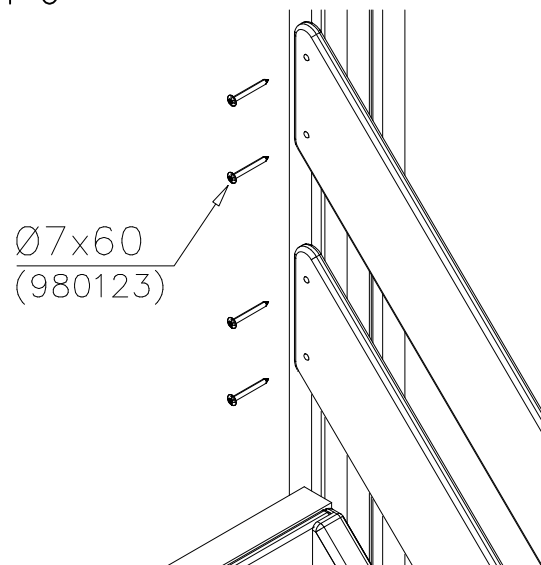

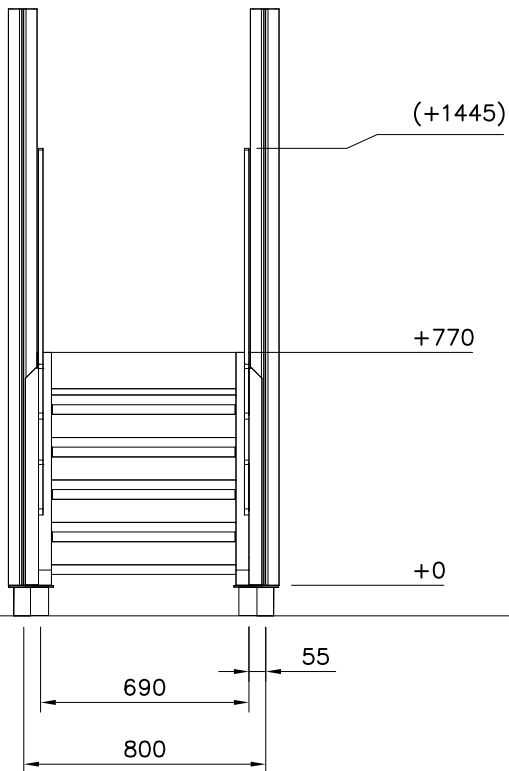



STAIRS OPTIONS +870

707191 	707191-602 DARK BROWN 707191-603 LIGHT BROWN 707191-604 LIGHT GRAY	
---	--	--

RAILING OPTIONS





RAILS 707146  15x145x1153	707146-701 BLUE 707146-702 YELLOW 707146-703 LIME 707146-704 DARK GRAY 707146-705 LIGHT GRAY 707146-706 RED	707146-707 GREEN 707146-708 FUXIA
---	--	--------------------------------------

POST 707145  43x93x717	707145-602 DARK BROWN 707145-603 LIGHT BROWN 707145-604 LIGHT GRAY	
---	--	--

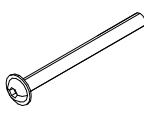
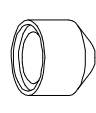
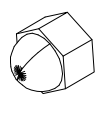

POST OPTIONS

--	--	--

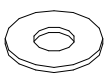

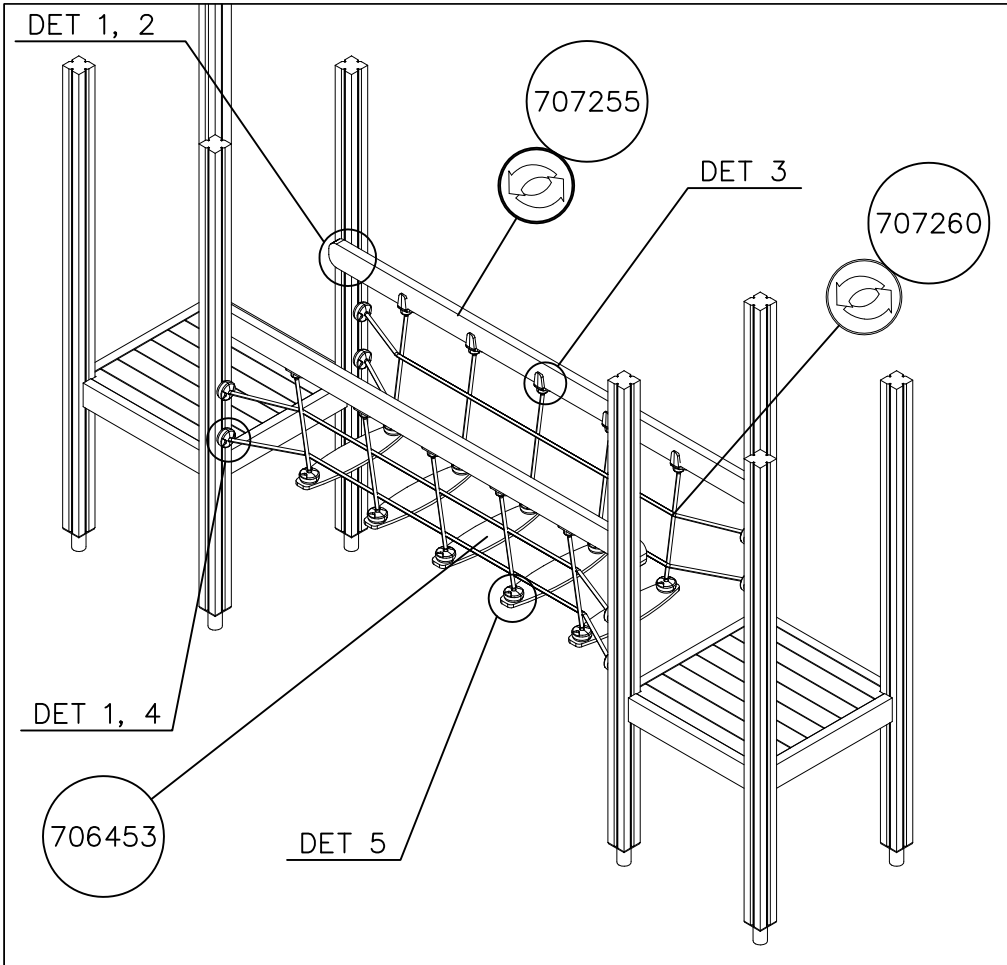
--	--	--

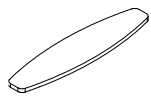
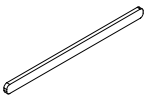
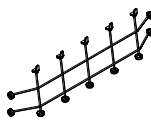
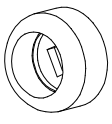
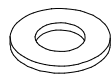
① 707191  +870	PCS 1	② 707145  43x93x717	PCS 2	③ 707146  15x145x1153	PCS 4	④ 900859  M8x90	PCS 2	⑤ 905104  M10	PCS 4	⑥ 909633  M8	PCS 2
⑦ 980123  Ø7x60	PCS 8	⑧ 980128  Ø7x40	PCS 15	⑨ 980152  Ø24/8.4x2	PCS 2		PCS		PCS		PCS

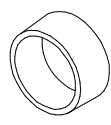
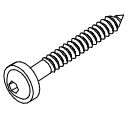

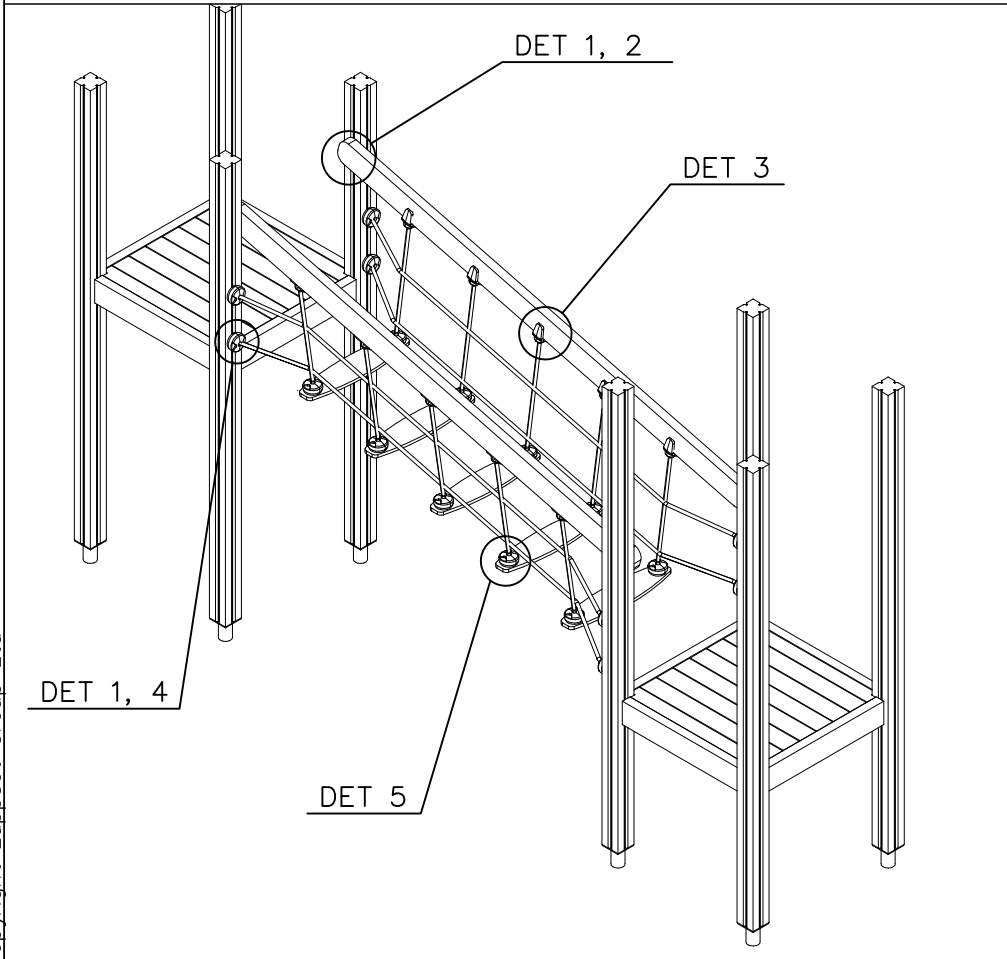
① 706453	PCS	② 707255	PCS
	5		2
15x145x600		45x120x2480	
③ 707260	PCS	④ 905083	PCS
	2		4
2375x600		Ø32	
⑤ 980151	PCS	⑥ 909232	PCS
	4		4
Ø16/8.4		8x120	
⑦ 905112	PCS	⑧ 900240	PCS
	4		16
Ø22		Ø8x70	

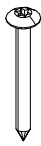

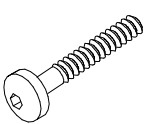
⑨ 980123	PCS	⑩ 980128	PCS
	20		10
Ø7x60		Ø7x40	
⑪ 980150	PCS	⑫ 901899	PCS
	20		20
M8		M8x45	
	PCS		PCS
	PCS		PCS

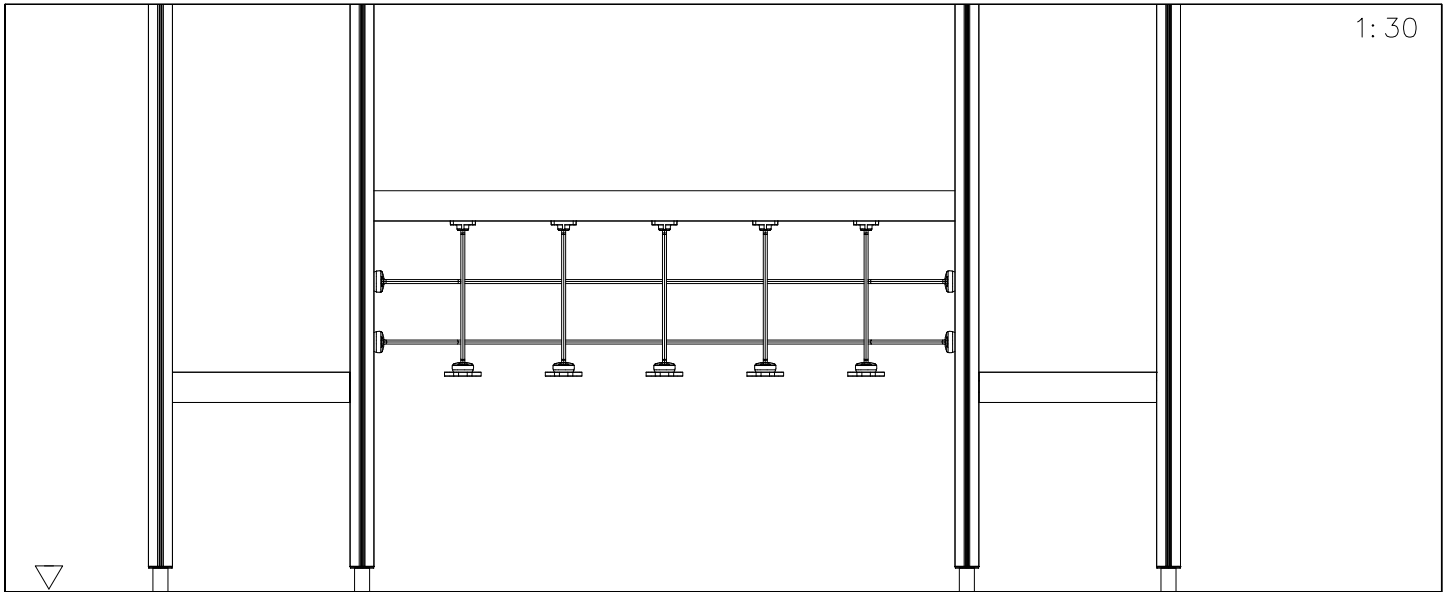

1:30

2400

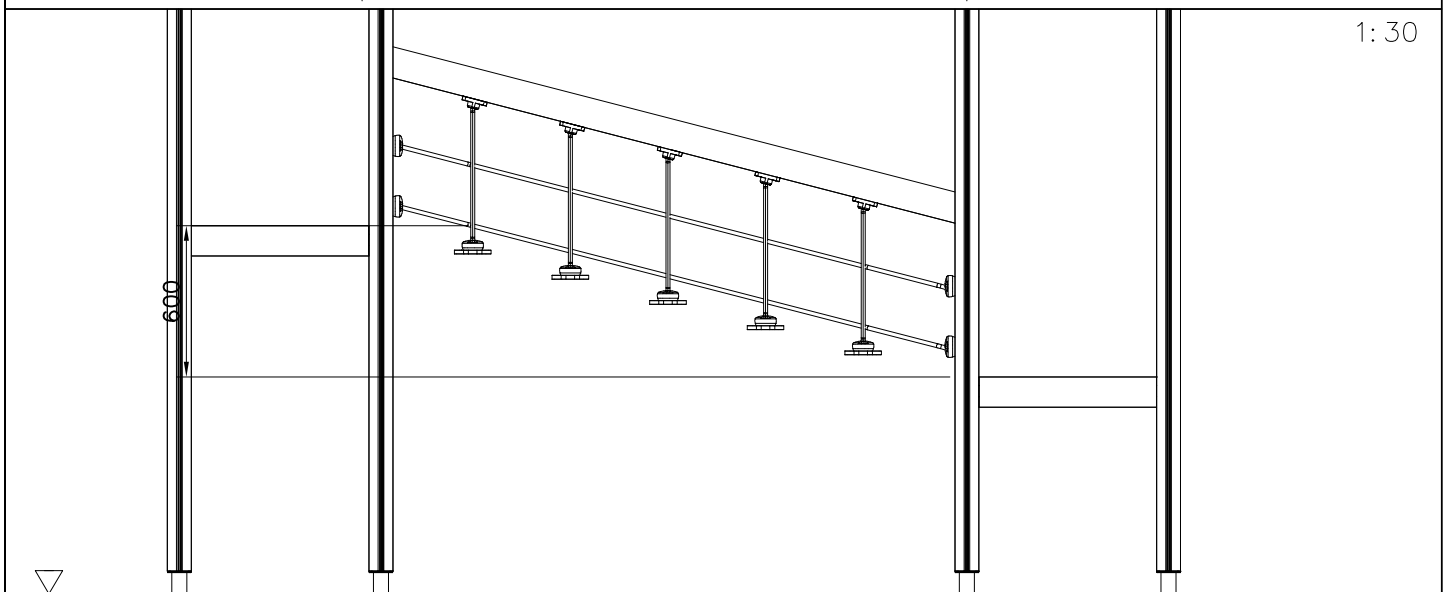

1:30

600

2320

NET OPTIONS

707260

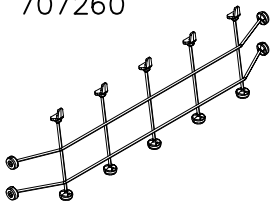

2375x600

- 707260-301 BLUE
- 707260-302 RED
- 707260-303 BEIGE
- 707260-304 GRAY
- 707260-305 BLACK
- 707260-306 YELLOW

RAILING OPTIONS

707255

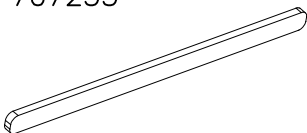

45x120x2480

- | | |
|----------------------|-------------------|
| 707255-605 DARK GRAY | 707255-609 GREEN |
| 707255-606 GRAY | 707255-610 YELLOW |
| 707255-607 RED | 707255-611 LIME |
| 707255-608 BLUE | 707255-612 FUXIA |

DET 1

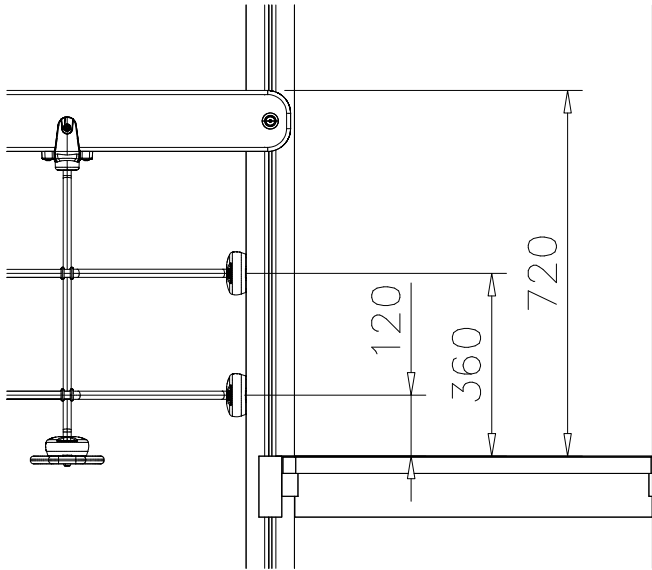

DET 2

Note:
in side
Bridge

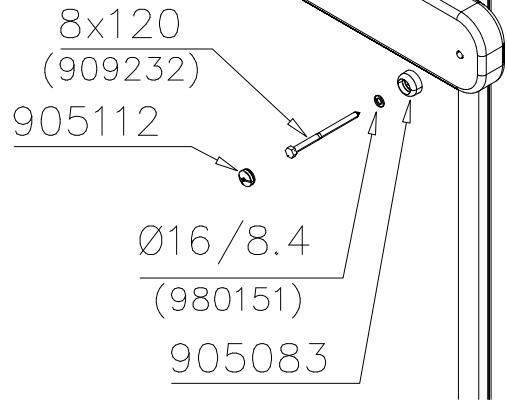

DET 3

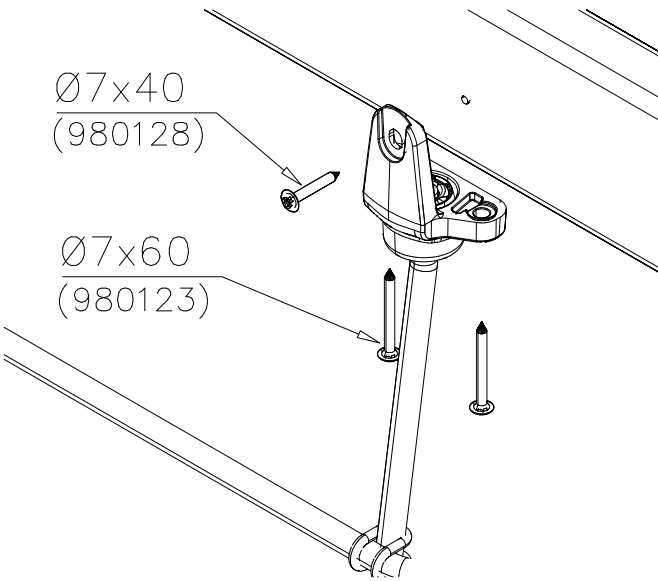

DET 4

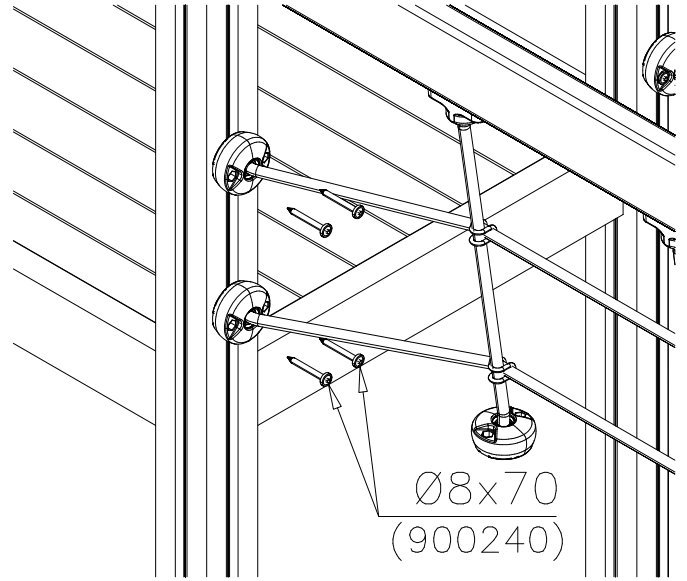



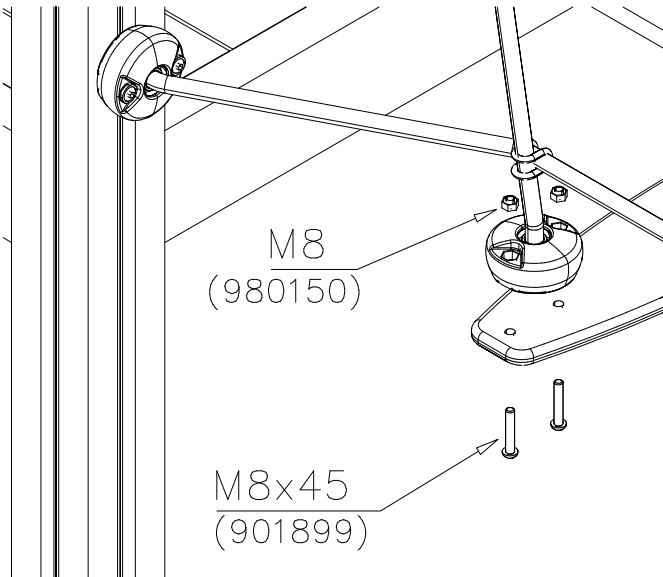

DET 5

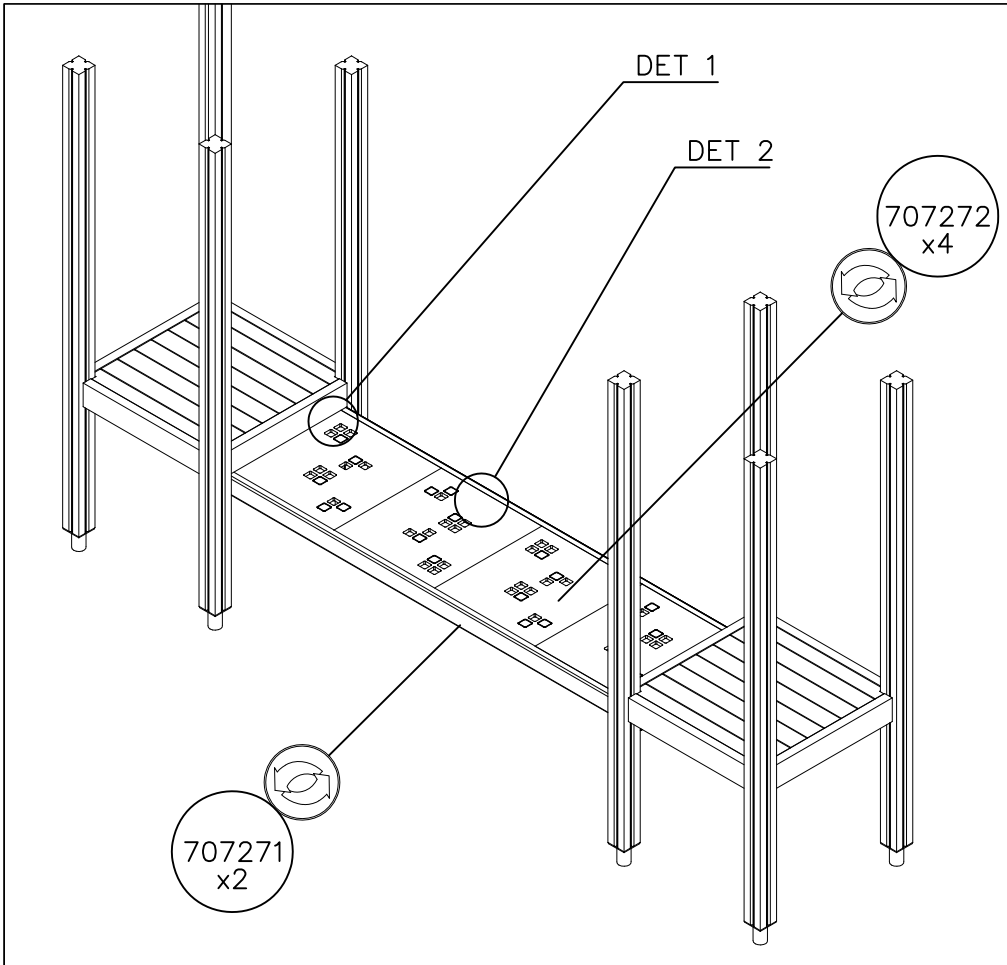

DET 6

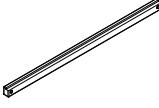
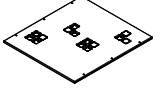

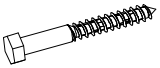
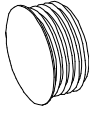

①	707271	PCS	②	707272	PCS
		2			4
					
	70x95x2480			15x630x590	
③	980154	PCS	④	909224	PCS
		4			4
					
	Ø24/13			12x100	
⑤	905103	PCS	⑥	980123	PCS
		4			24
					
	PT-28/32-H			Ø7x60	
		PCS			PCS

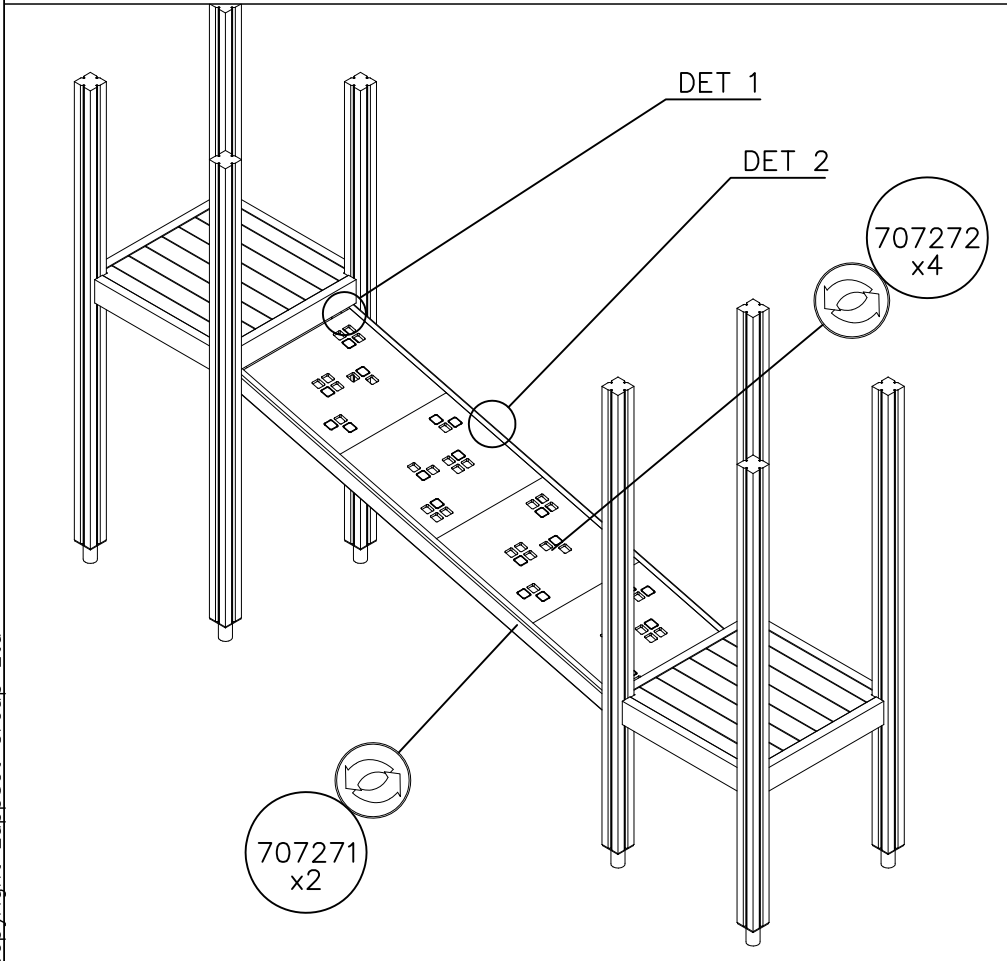

		PCS			PCS
		PCS			PCS
		PCS			PCS
		PCS			PCS

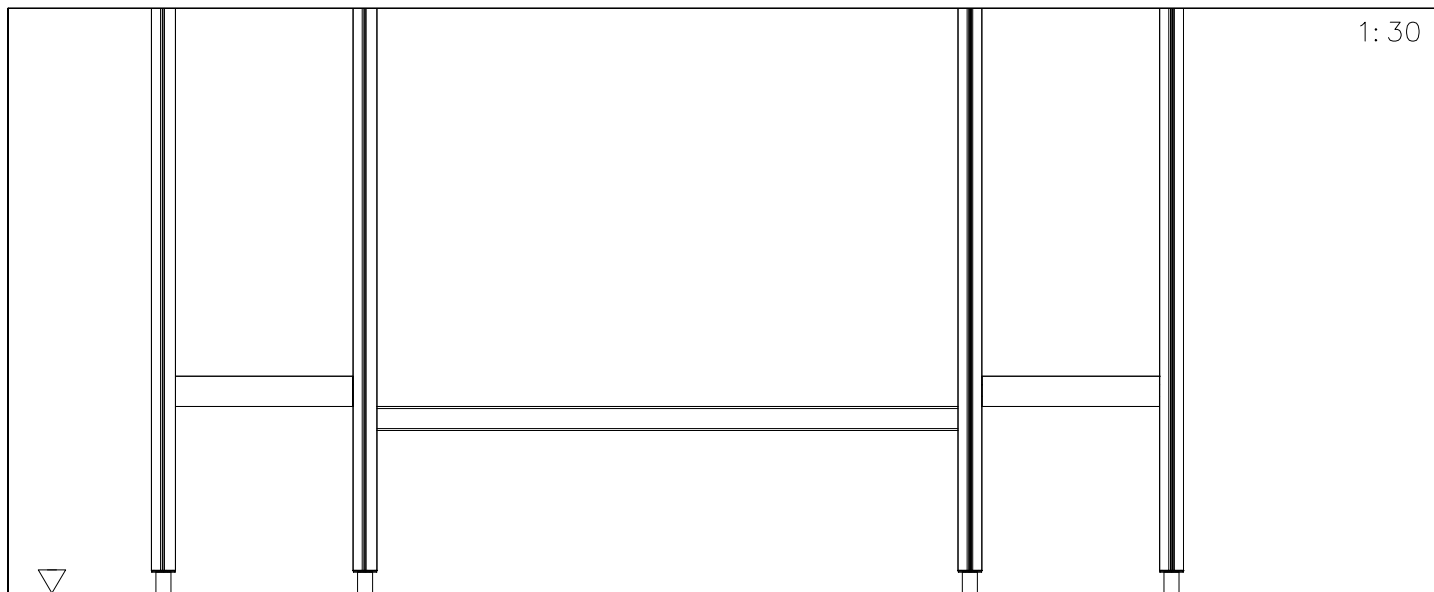

2400

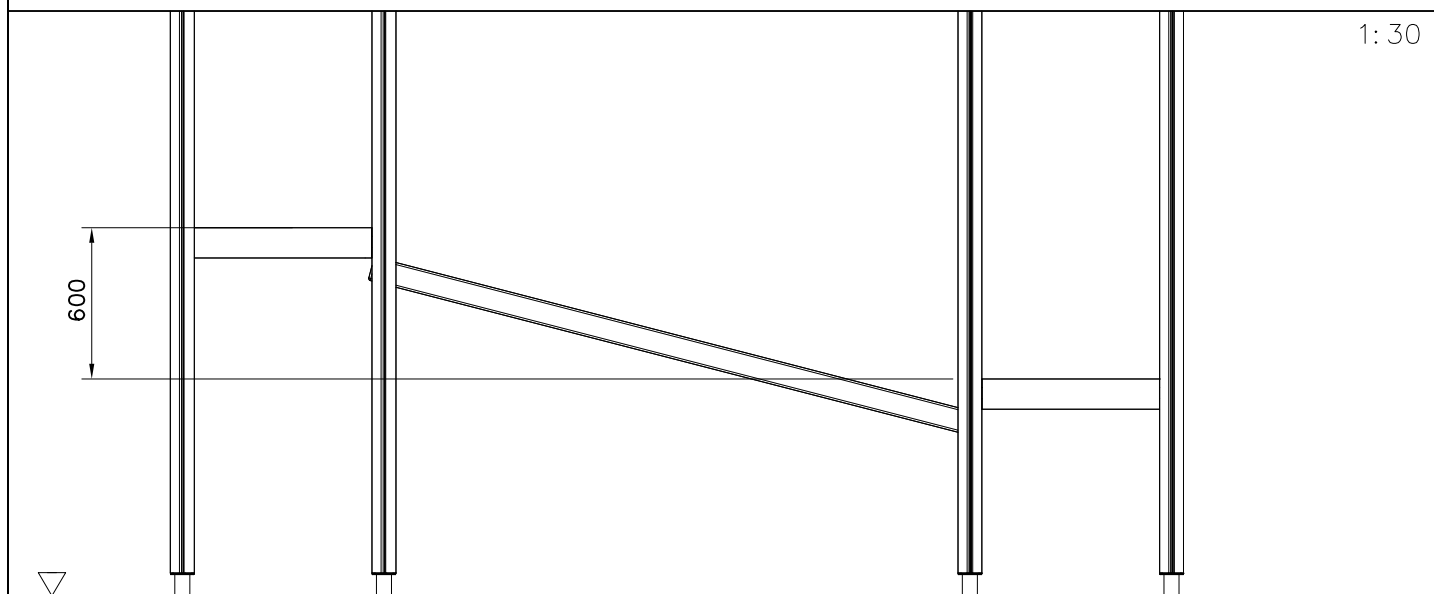

2325

PLATE OPTIONS

707272

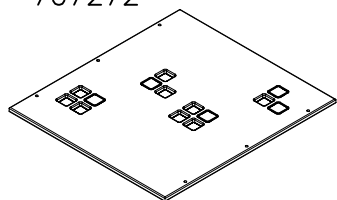

15x630x590

- 707272-701 BLUE
- 707272-702 YELLOW
- 707272-703 LIME
- 707272-704 DARK GRAY
- 707272-705 GRAY
- 707272-706 RED

- 707272-707 GREEN
- 707272-708 FUXIA

BOOM OPTIONS

707271

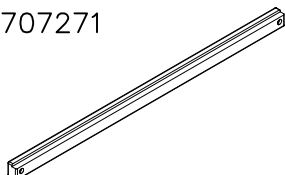



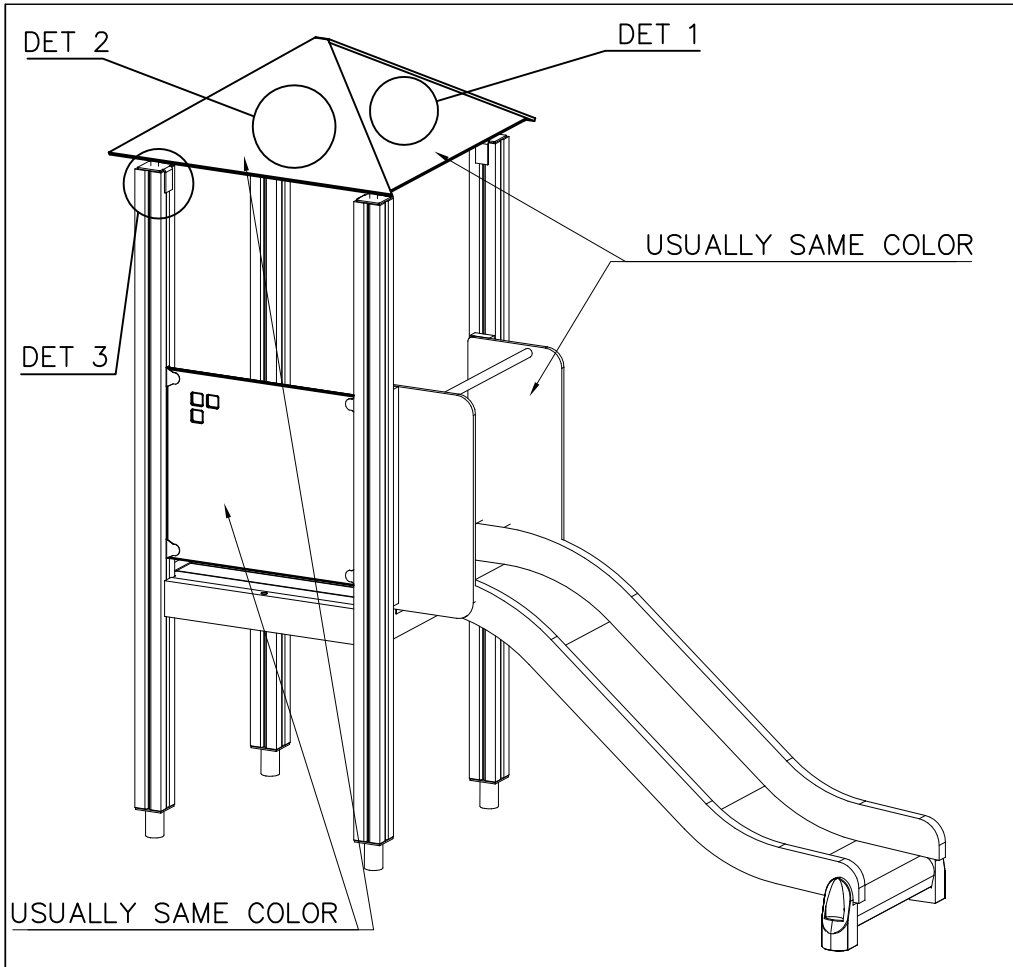

70x95x2480

- 707271-602 DARK BROWN
- 707271-603 LIGHT BROWN
- 707271-604 LIGHT GRAY

<p>DET 1</p> <p>905103 12x100 (909224) Ø24/13 (980154)</p>	<p>DET 2</p> <p>BOOM</p> <p>Ø7x60 (980123)</p>
<p>DET 3</p>	<p>DET 4</p>
<p>DET 5</p>	<p>DET 6</p>



① 909850	PCS 20	② 909256	PCS 28
			
M8x25		Ø16/8.4	
③ 909633	PCS 20	④ 980123	PCS 8
			
M8		Ø7x60	
	PCS		PCS
	PCS		PCS

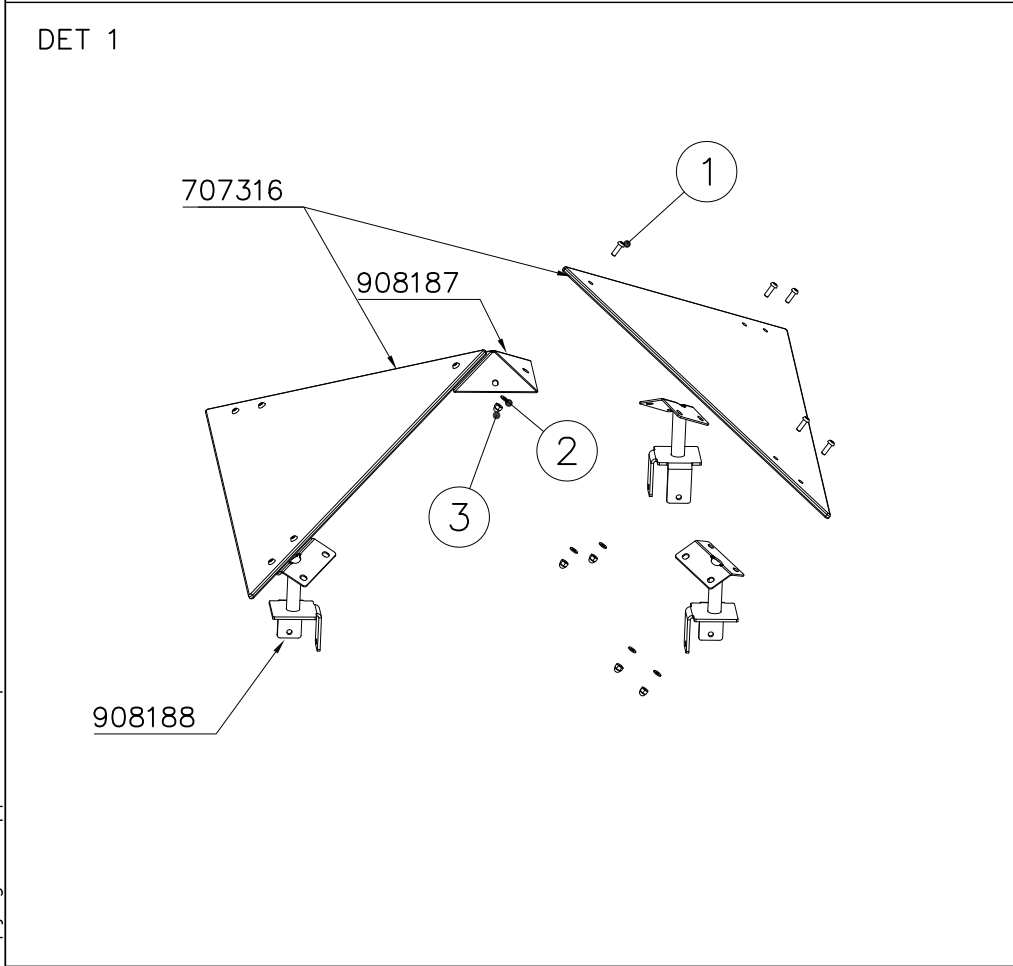

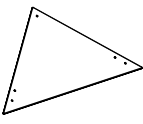
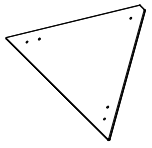
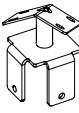
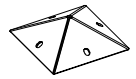
	PCS		PCS
○ 707316	PCS 2	○ 707317	PCS 2
			
○ 908188	PCS 4	○ 908187	PCS 1
			
	PCS		PCS

DET 2

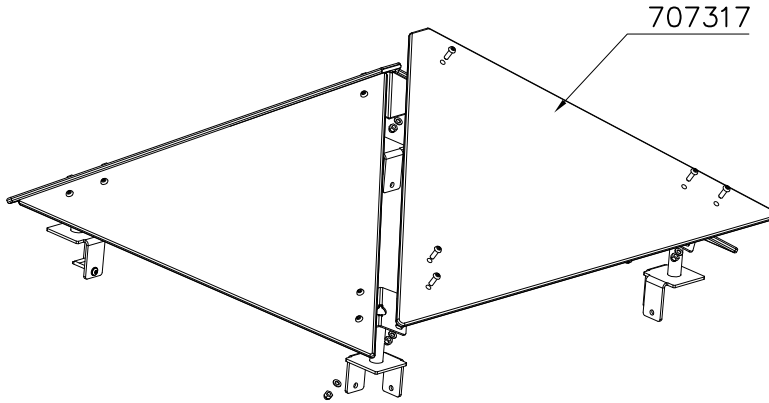

DET 3

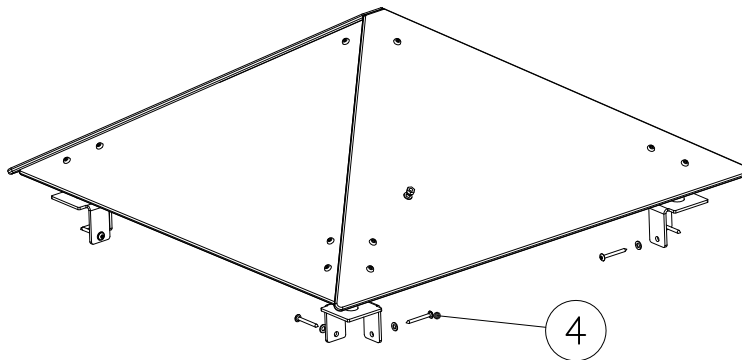
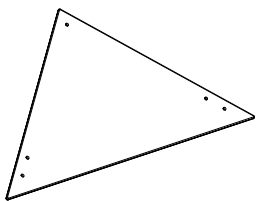

PLATE COLOR OPTIONS

707316



10x572x949

- 701 BLUE
- 702 YELLOW
- 703 LIME
- 704 DARK GRAY
- 705 LIGHT GRAY
- 706 RED
- 707 GREEN
- 708 FUXIA

IF PRODUCT HAS A SLIDE,
THEN THE SAME COLOR AS
START-OFF PLATES

707317

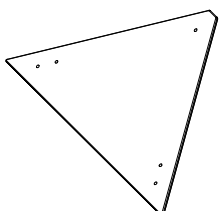



10x591x1013

- 701 BLUE
- 702 YELLOW
- 703 LIME
- 704 DARK GRAY
- 705 LIGHT GRAY
- 706 RED
- 707 GREEN
- 708 FUXIA

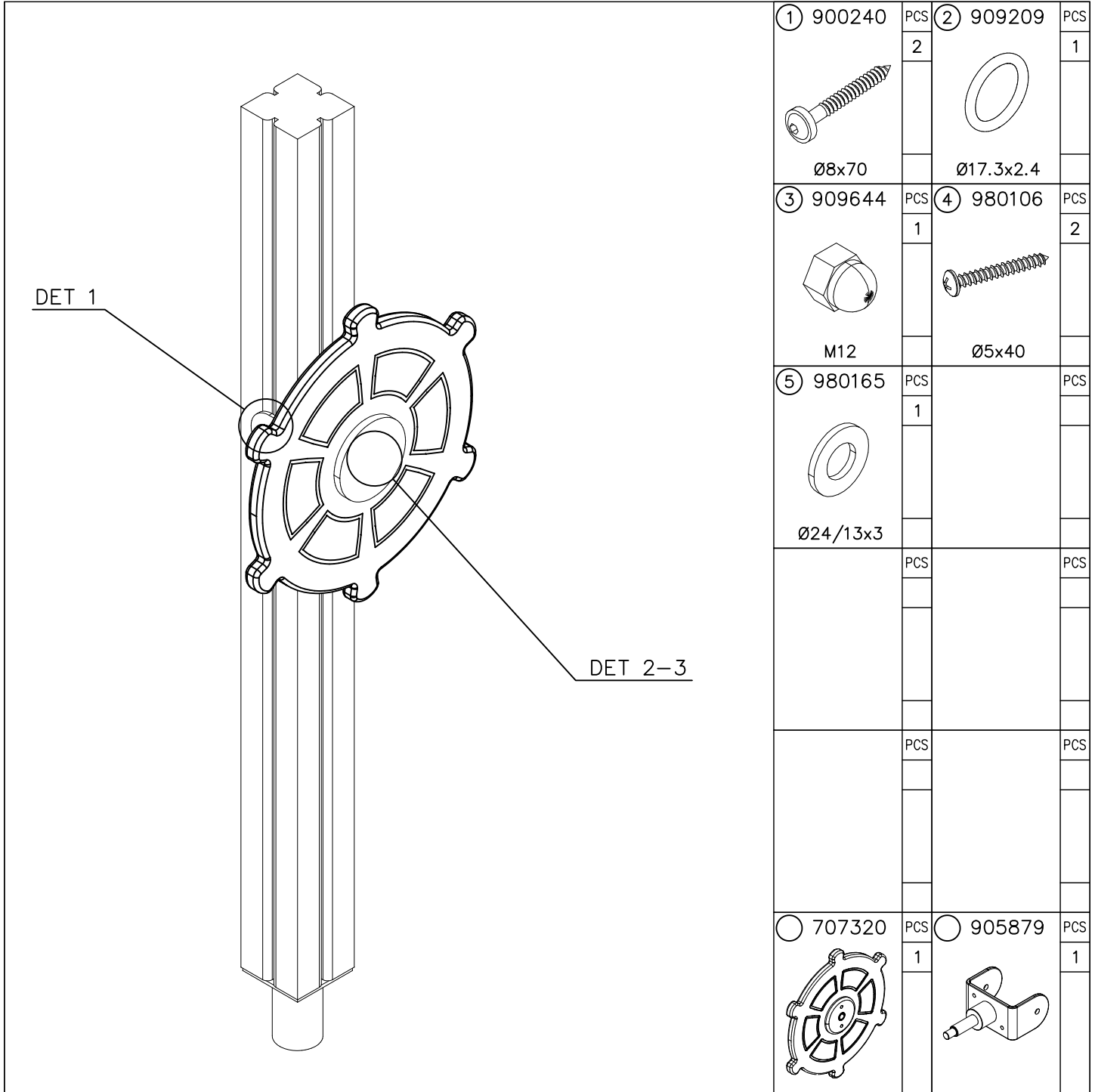
IF PRODUCT HAS A WALLS,
THEN THE SAME COLOR AS
WALL PLATES

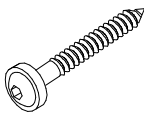
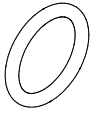
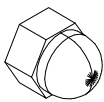
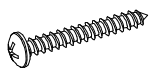

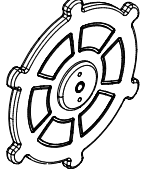
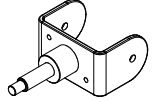

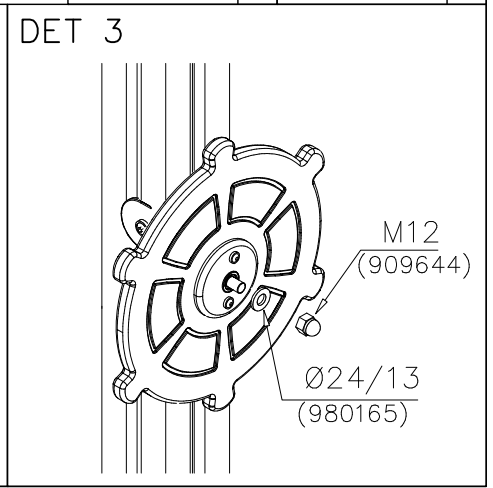
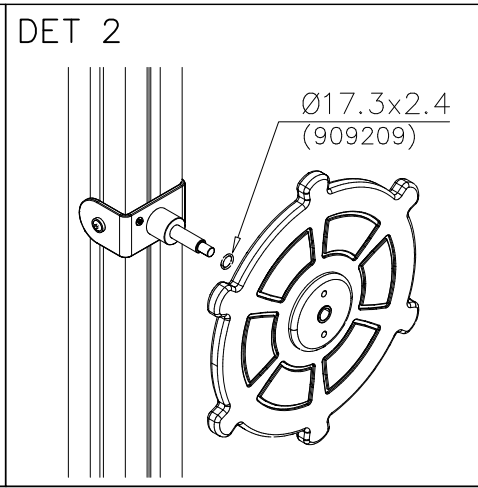
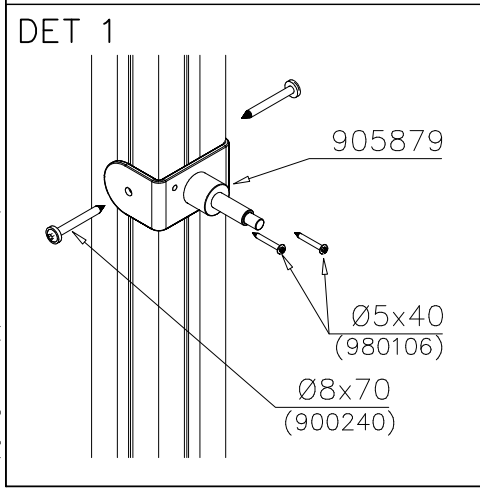
① 900240	PCS	② 909209	PCS
	2		1
Ø8x70		Ø17.3x2.4	
③ 909644	PCS	④ 980106	PCS
	1		2
M12		Ø5x40	
⑤ 980165	PCS		PCS
	1		
Ø24/13x3			
	PCS		PCS
	PCS		PCS
○ 707320	PCS	○ 905879	PCS
	1		1

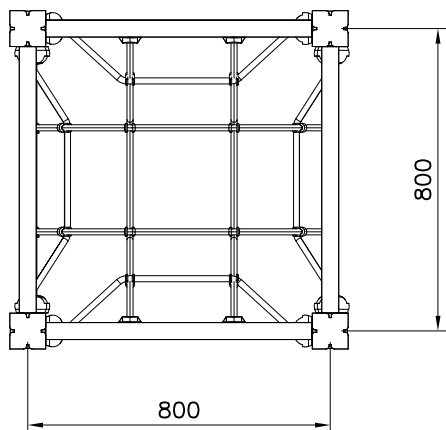
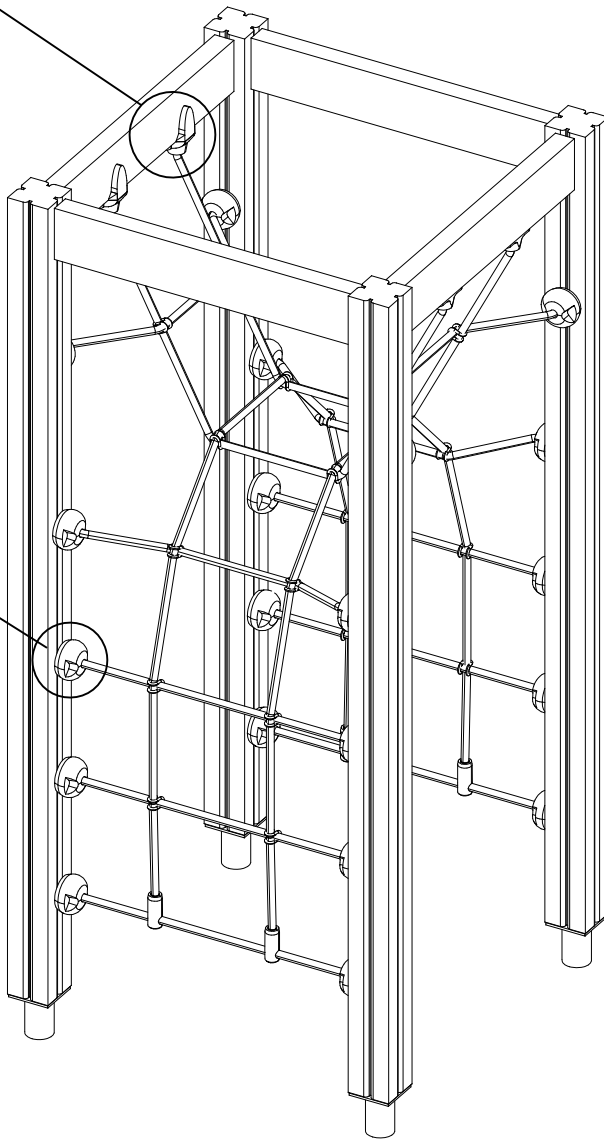

DET 1

DET 2

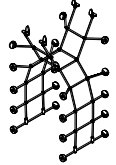
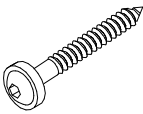

① 707341  1520x705	PCS 1	② 900240  Ø8x70	PCS 40
③ 980123  Ø7x60	PCS 8	④ 980128  Ø7x40	PCS 4
	PCS		PCS
	PCS		PCS
	PCS		PCS
	PCS		PCS

NET OPTIONS

707341

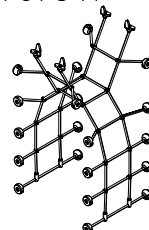

1520x705

- 707341-301 BLUE
- 707341-302 RED
- 707341-303 BEIGE
- 707341-304 GREY
- 707341-305 BLACK

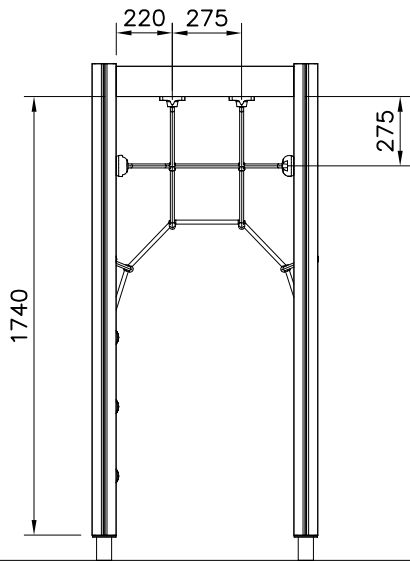

DET 1

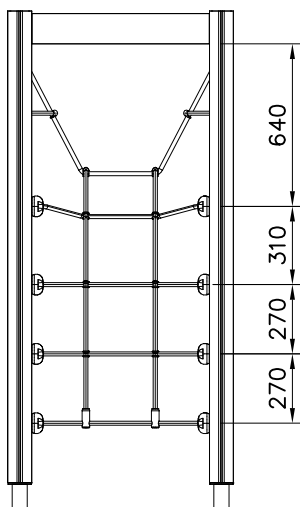
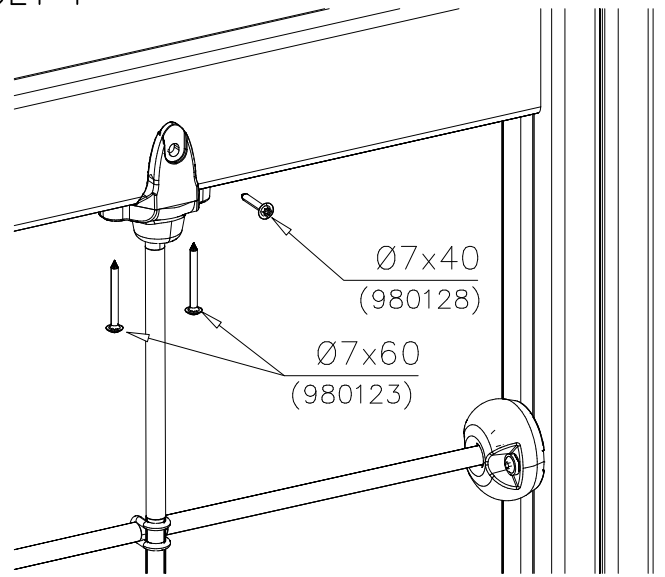

DET 2

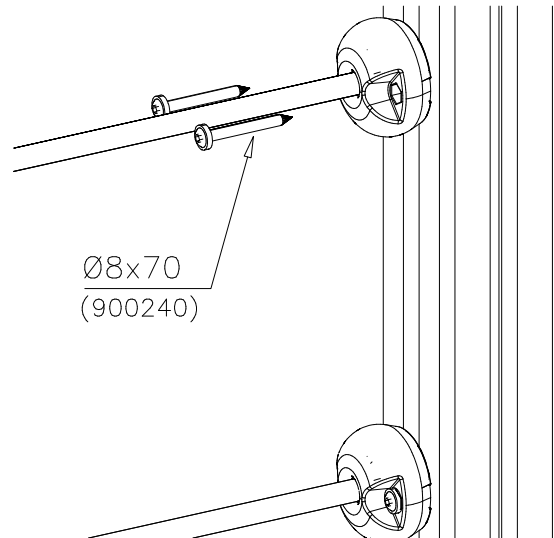

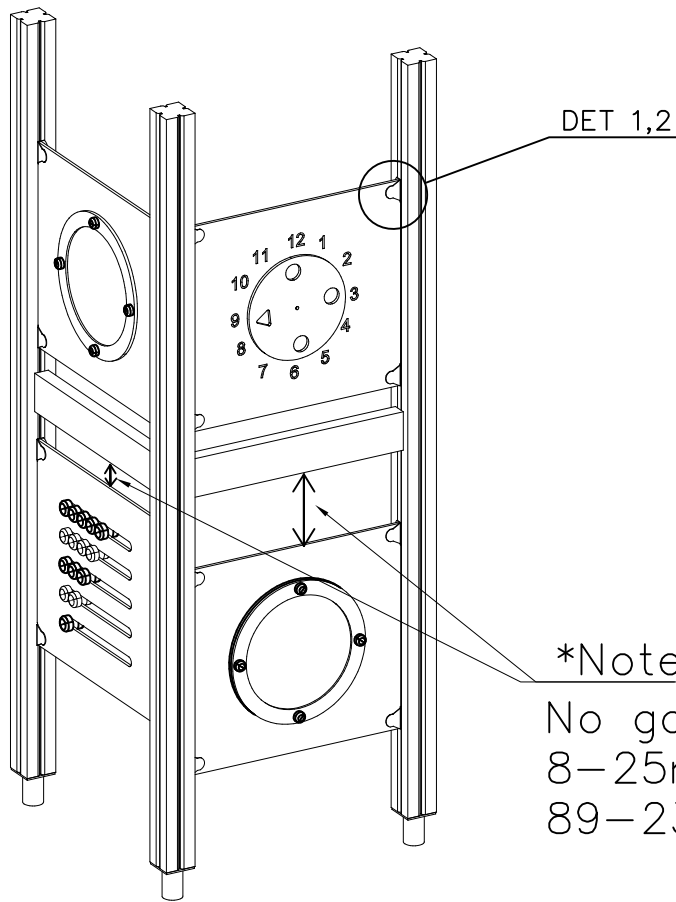

① 903176	PCS	② 909850	PCS
	4		4
		M8x25	
③ 909256	PCS	④ 909633	PCS
	8		4
Ø16/8.4x1.6		M8	
⑤ 980123	PCS		PCS
	4		
Ø7x60			

*Note:

No gaps between:
8–25mm
89–230mm

COLOR OPTIONS

-701	BLUE
-702	YELLOW
-703	LIME
-704	DARK GRAY
-705	LIGHT GRAY
-706	RED
-707	GREEN
-708	FUXIA

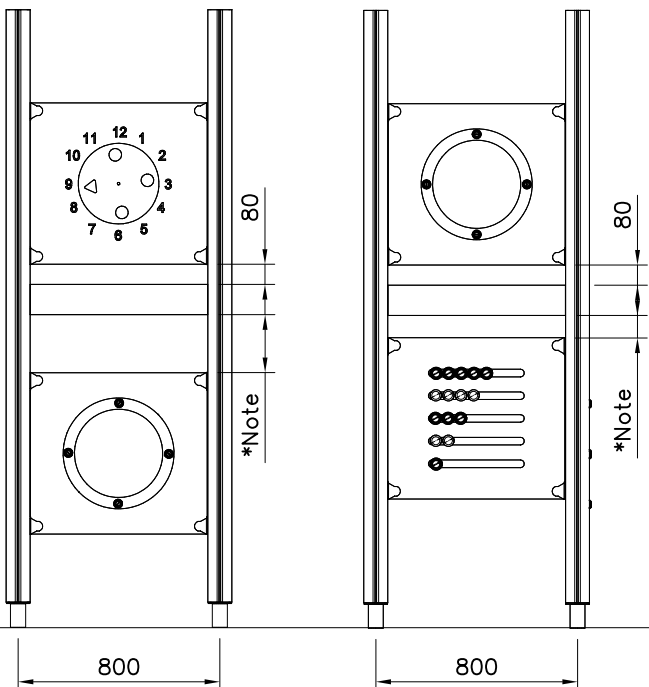

GAME WALL OPTIONS

706766	706772	706308	707453
			
640x702	640x702	640x702	640x702
707209	705705	707433	707386
			
640x702	640x702	640x702	640x702
709403	709358	709405	
			
640x702	640x702	420x702	

DET 1

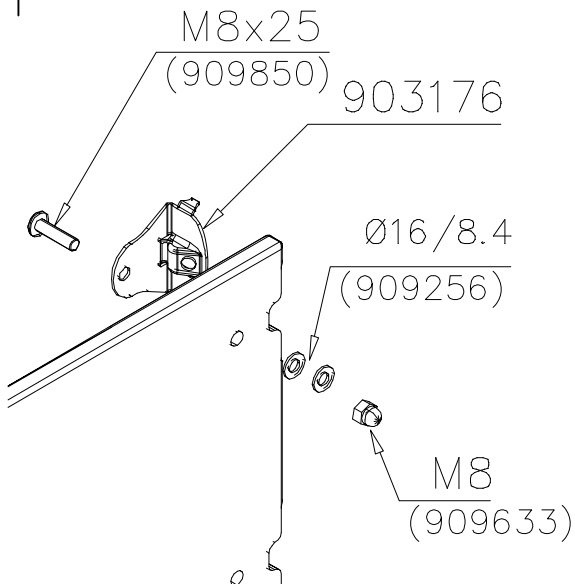

DET 2

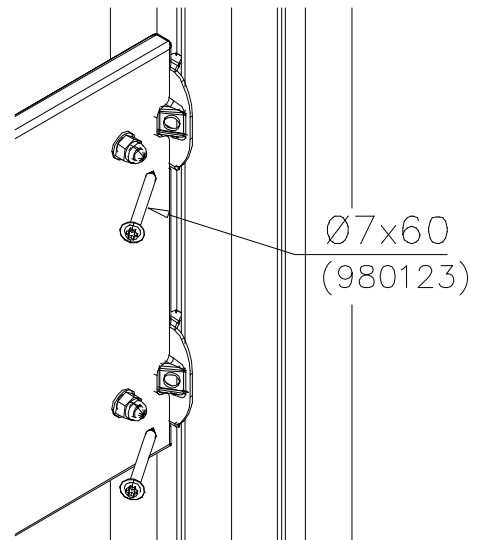



Tuotekyltti tulee tuotteen mukana yhdellä seuraavista tavoista:

1) Metallinen tuotekyltti ja kiinnitysruuvit

- Kiinnitä tuotekyltti ruuveilla tolppaan noin 2 metrin korkeuteen kuvan 1 mukaisesti.

2) Tuotekylttitarra

- Puhdista maalattu metalli- tai vaneripinta pölystä ja kosteudesta. Liimaa tarra kuvan 2 mukaisesti.
- Huom. Älä kiinnitä tarraa karheapintaiseen laminaattiin tai maalattuun puuhun.

Vår produktmärkning levereras på ett av följande sätt:

1) Produktskylt i metall

- Fäst skylten med de medföljande skruvarna

2) Självhäftande produktetikett

- Rengör den pulverlackerade metallytan eller laminatyten så att den blir fri från smuts och fukt. Fäst etiketten enligt fig. 2.
- Obs! Fäst ej etiketten på detaljer med skrovlig yta eller på målat trä.

Product label is delivered by one of following ways:

1) Metal product label and screws

- Fasten the label with screws.

2) Label sticker

- Clean the painted metal or plywood surface from dirt and moisture. Fasten the sticker as shown in the figure 2.
- Note. Do not attach the sticker to rough surfaced laminate or painted wood.

La plaque d'informations produit est livrée sous l'une de ces 3 formes :

1) Plaque métallique et vis

- Fixez la plaque à l'aide des vis.

2) Etiquette autocollante

- Avant de coller l'étiquette, nettoyez le composant métallique peint ou la plaque de contreplaqué, de toute saleté. La surface doit être sèche (voir image 2).
- Attention, ne pas coller l'étiquette sur une surface lamellé-collée irrégulière ou sur du bois peint.

Die Auslieferung des Produktaufklebers erfolgt auf eine dieser Arten:



1) Produkt-Schild aus Metall incl. Schrauben

- Die Befestigung des Schildes erfolgt mittels der Schrauben.



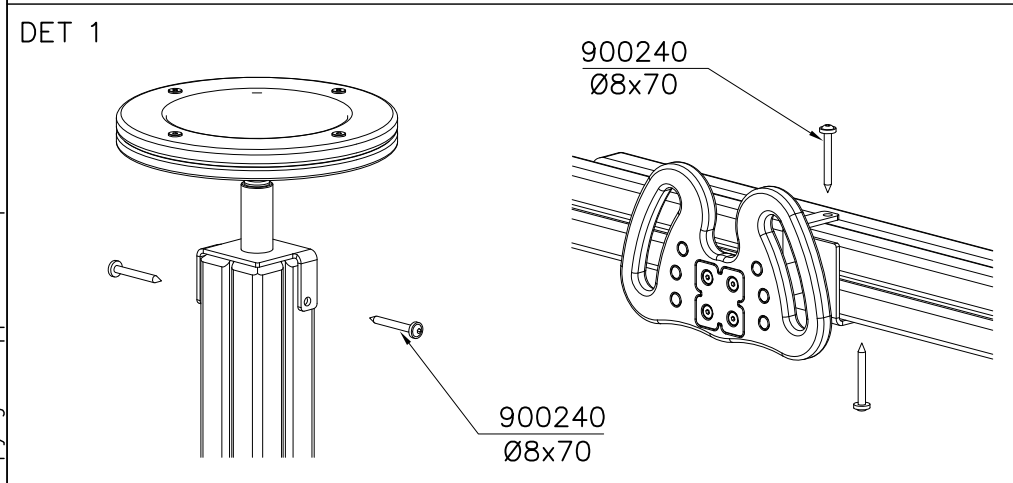
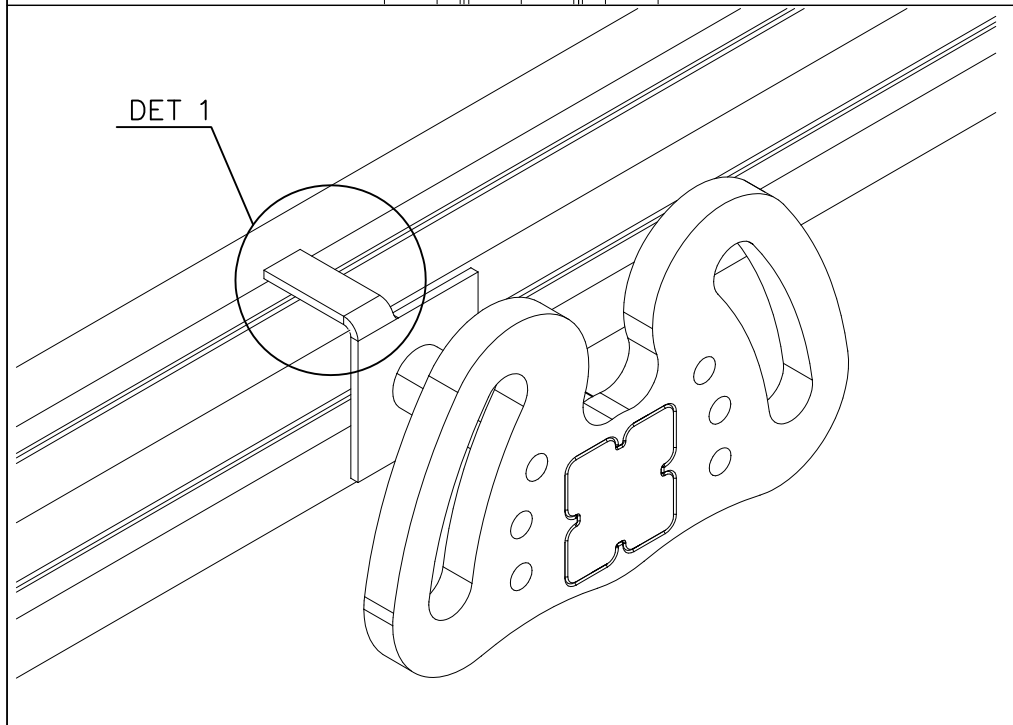
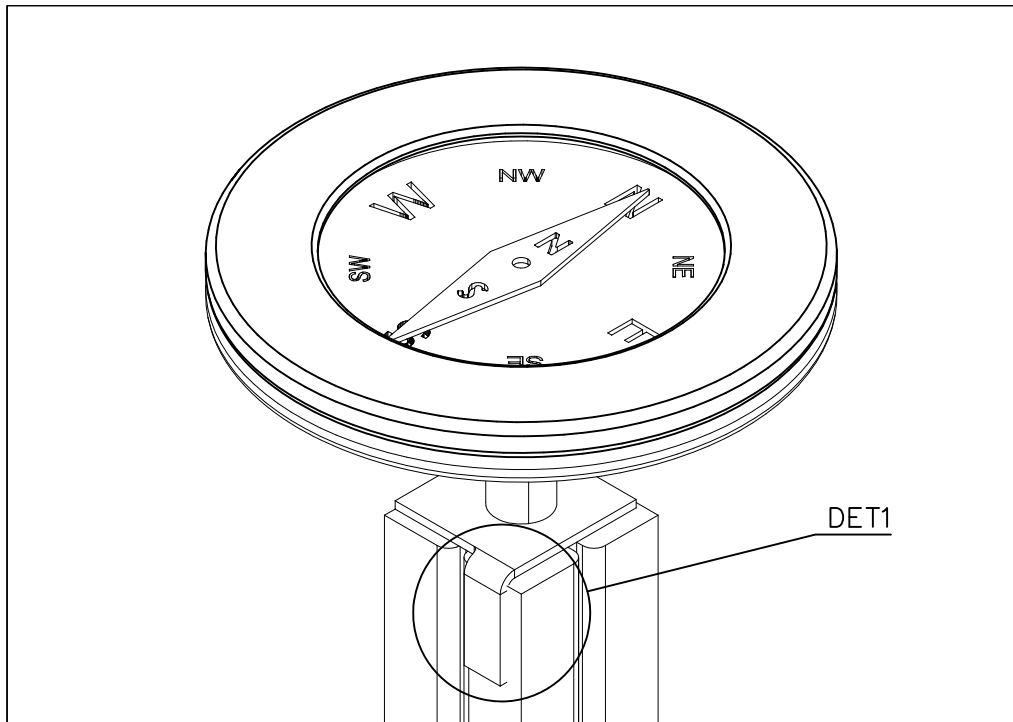

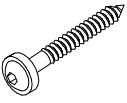

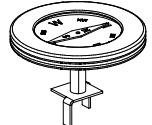
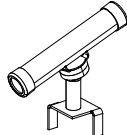
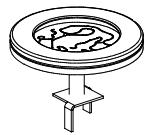
2) Aufkleber

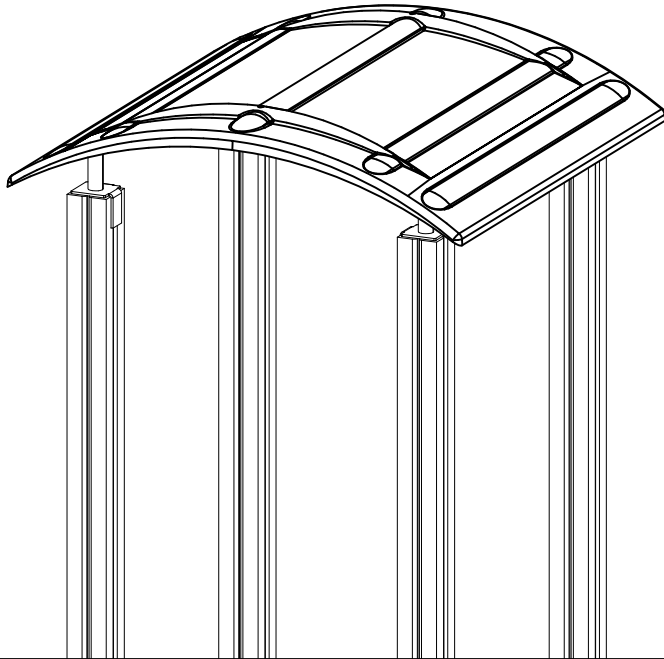
- Entfernen Sie zunächst Schmutz und Feuchtigkeit vom lackierten Metall bzw. von der Holzoberfläche und bringen Sie den Aufkleber wie im Bild oben rechts beschrieben auf den gesäuberten Untergrund auf.
- Beachten Sie: Bringen Sie den Aufkleber nicht auf raues laminiertes oder lackiertes Holz an.

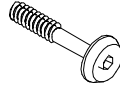



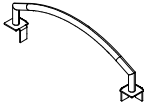



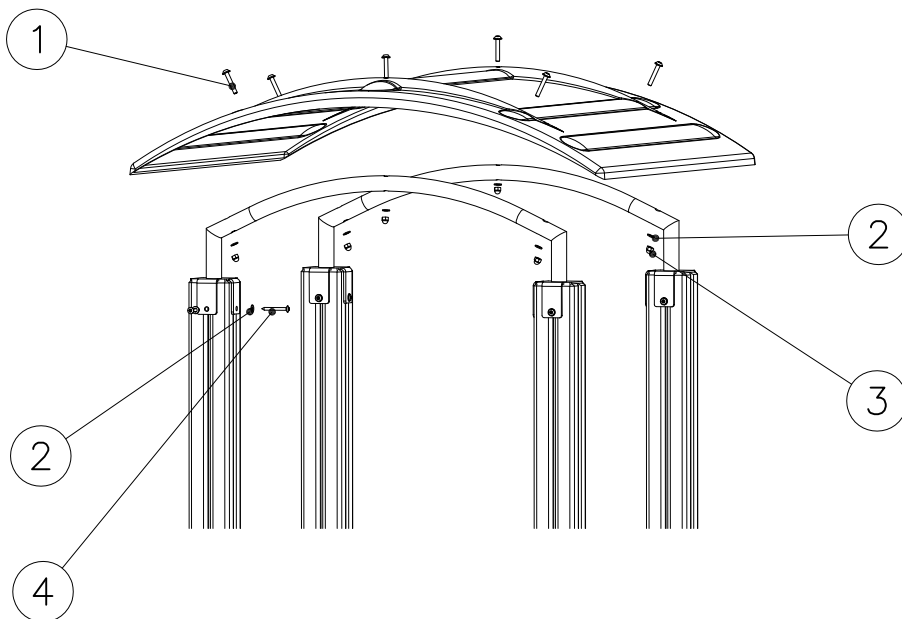

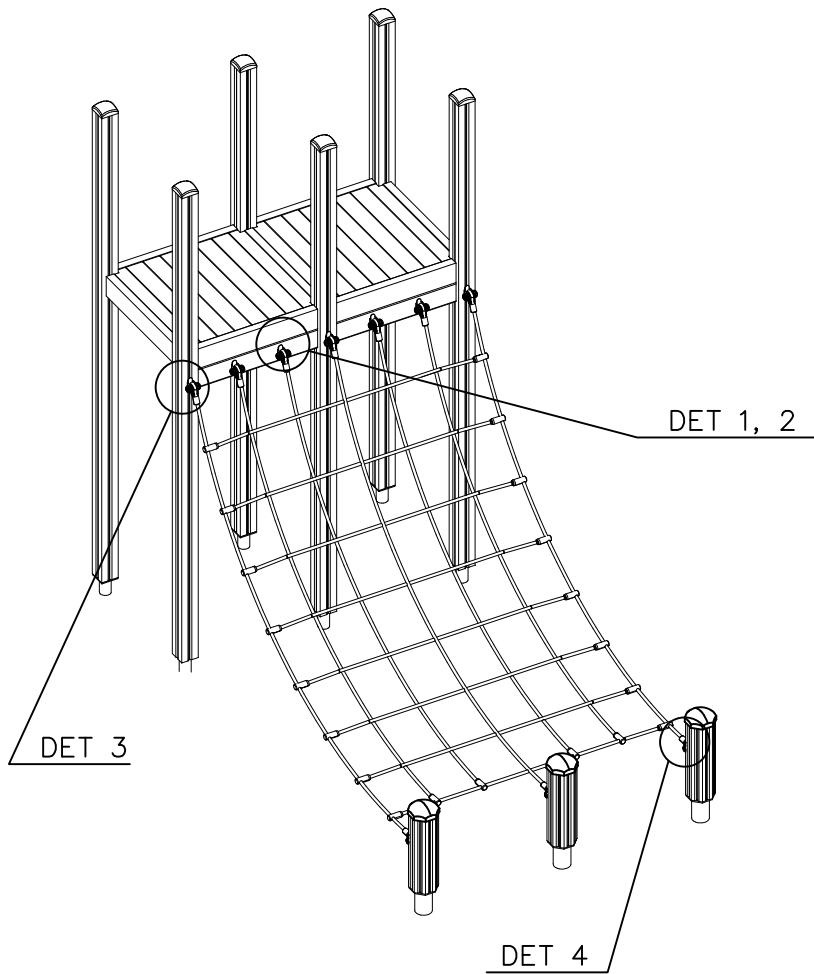
① 900240	PCS		PCS
	2		
Ø8x70			
	PCS		PCS
	PCS		PCS
○ 707302	PCS	○ 707303	PCS
	1		1
○ 707304	PCS	○ 707305	PCS
	1		1
	PCS		PCS
	PCS		PCS



①	909868	PCS	②	909256	PCS
		6			14
					
	M8x50			Ø16/8.4	
③	909633	PCS	④	980123	PCS
		6			8
					
	M8			Ø7x60	
		PCS			PCS
		PCS			PCS
○	908330	PCS	○	908251	PCS
		2			1
					
				1100x1100x215	
		PCS			PCS
		PCS			PCS
		PCS			PCS





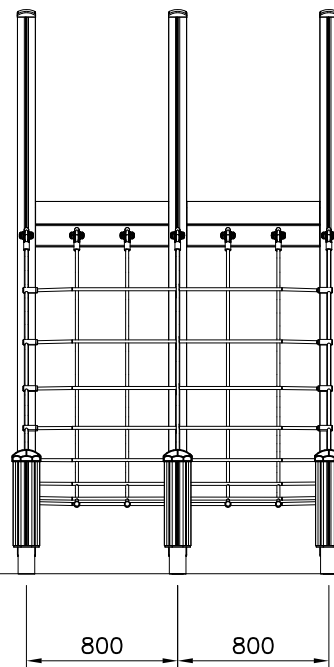
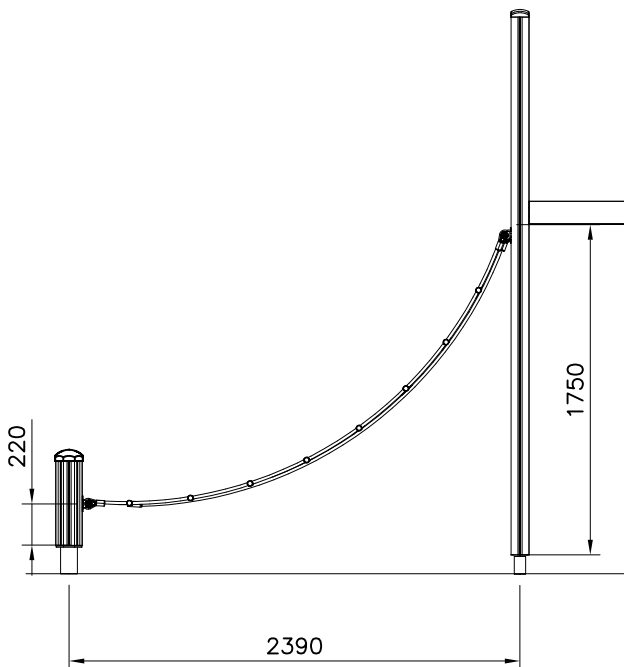

①	901899	PCS	②	905051	PCS
		8			8
					
	M8x45			Ø24/8.4	
③	980150	PCS	④	905103	PCS
		8			8
					
	M8			PT-28/32-H	
⑤	900240	PCS	⑥	903093	PCS
		6			6
					
	Ø8x70			Ø8x90	
		PCS	⑦	909256	PCS
					8
					
				Ø16/8.4	

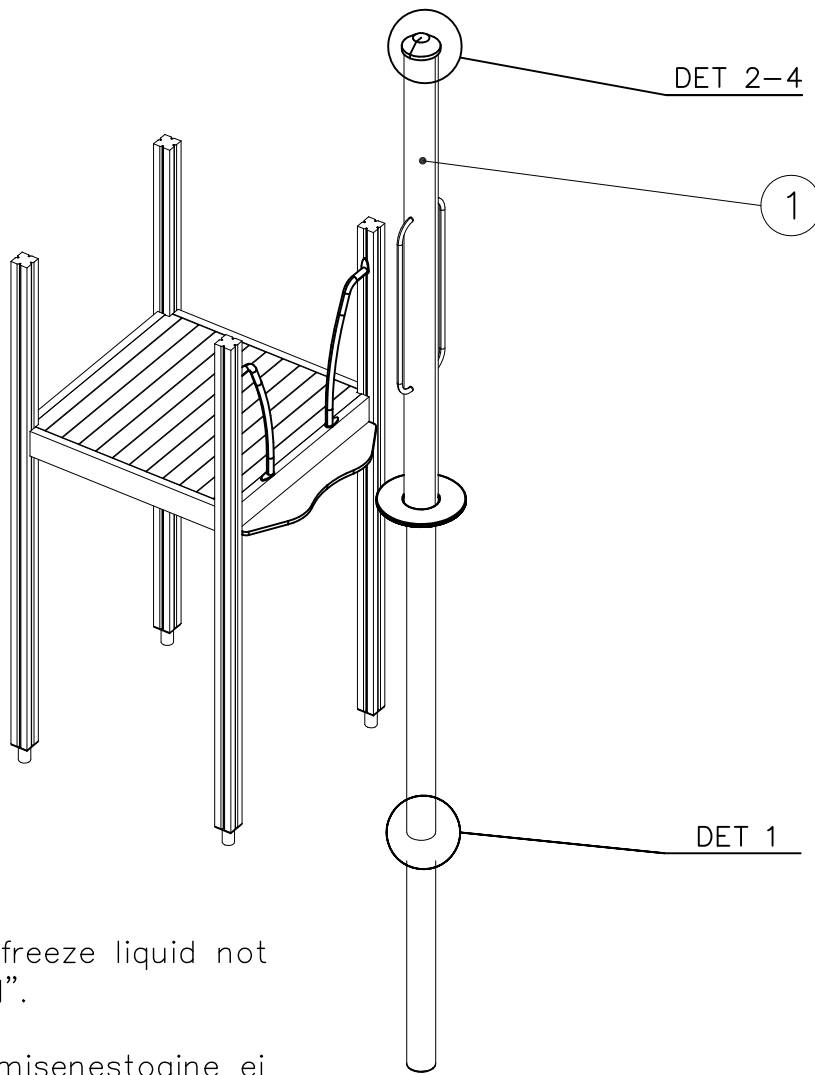

<p>DET 1</p> <p>8x45 Ø16/8.4</p>	<p>DET 2</p> <p>Ø24/8.4 M8 905103</p>	<p>DET 3</p> <p>8x70 8x60 905083</p>
<p>DET 4</p> <p>200 8x90</p>	<p>DET 5</p>	
<p>DEEP MOUNTING OPTION</p>	<p>Concrete 500x500x200 150 600 S</p>	<p>M10 905104 903112</p>



① 703703	PCS		PCS
	1		
L 4600			
	PCS		PCS
	PCS		PCS
	PCS		PCS

Note:
" Anti-freeze liquid not included".
Huom!
" Jäätymisenestoaine ei kuulu toimitukseen".

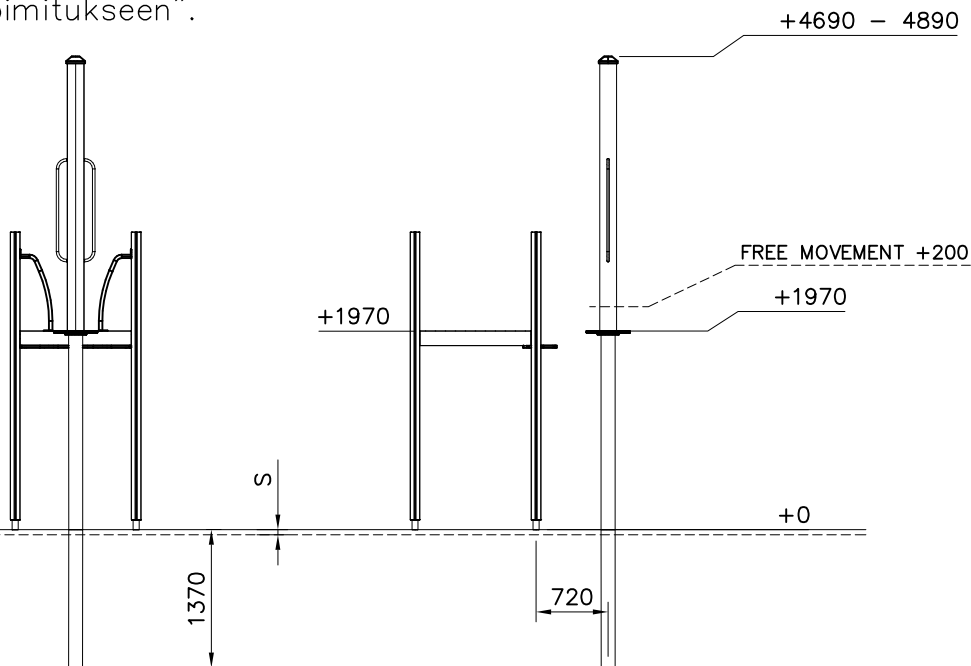

DET 1

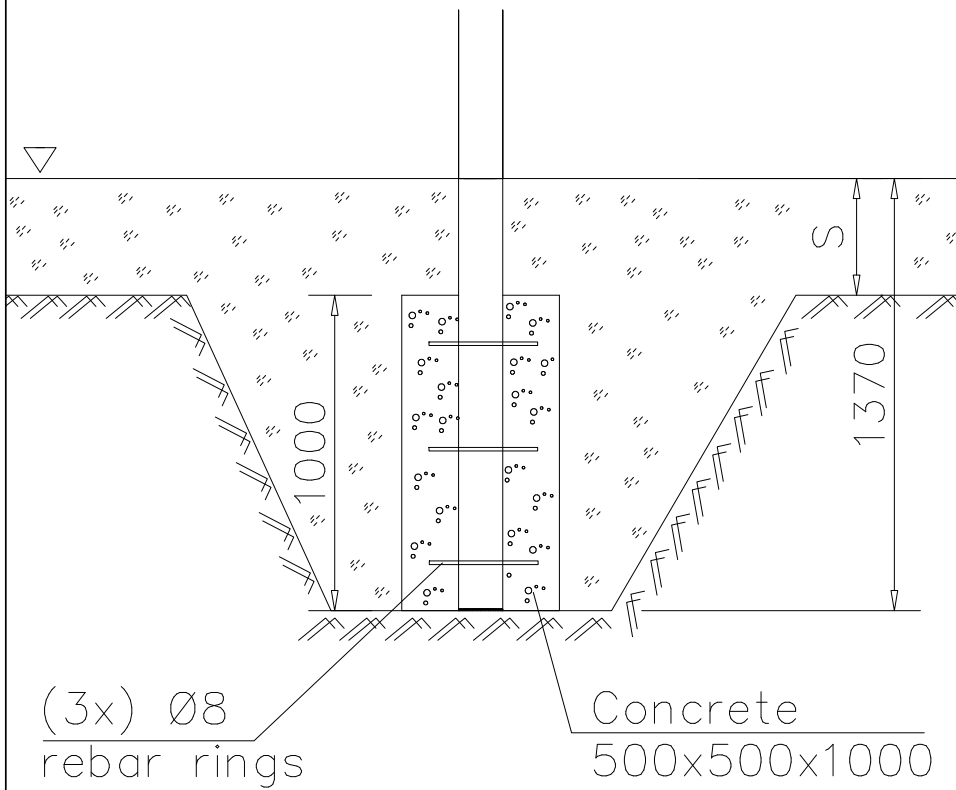

DET 2

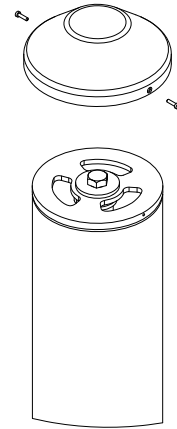

DET 3

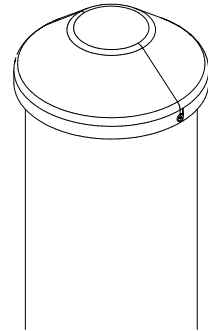

DET 4

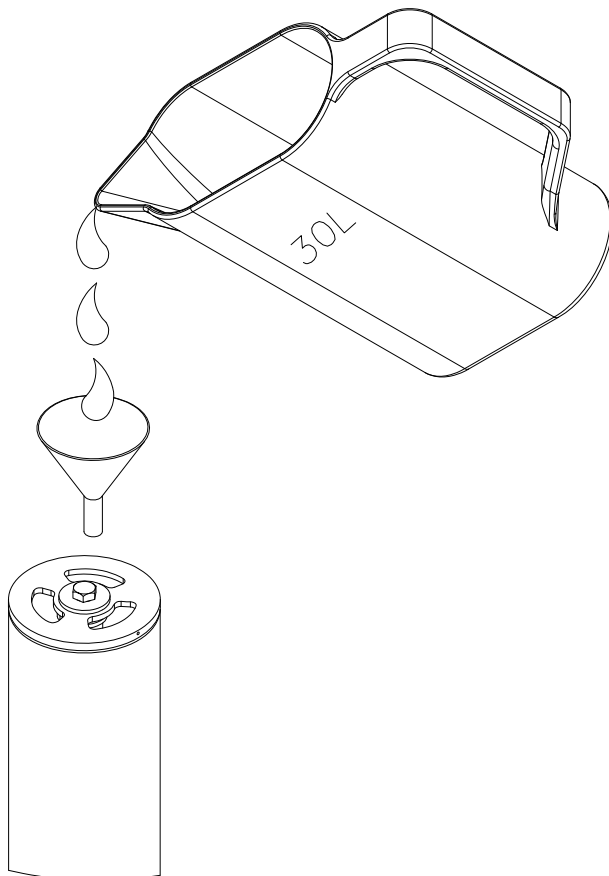

DET 5

DET 6

(DET 4)

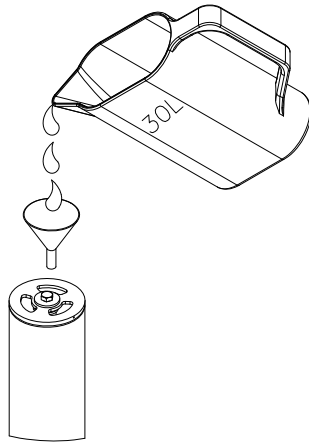







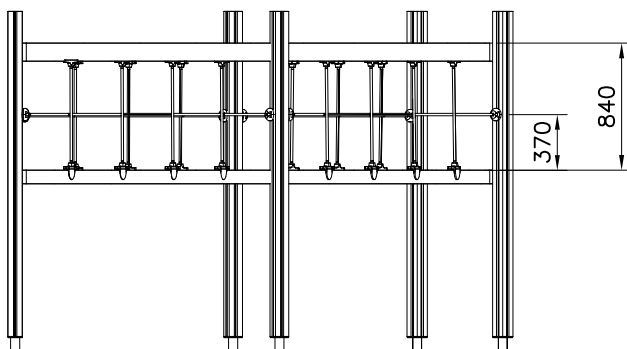
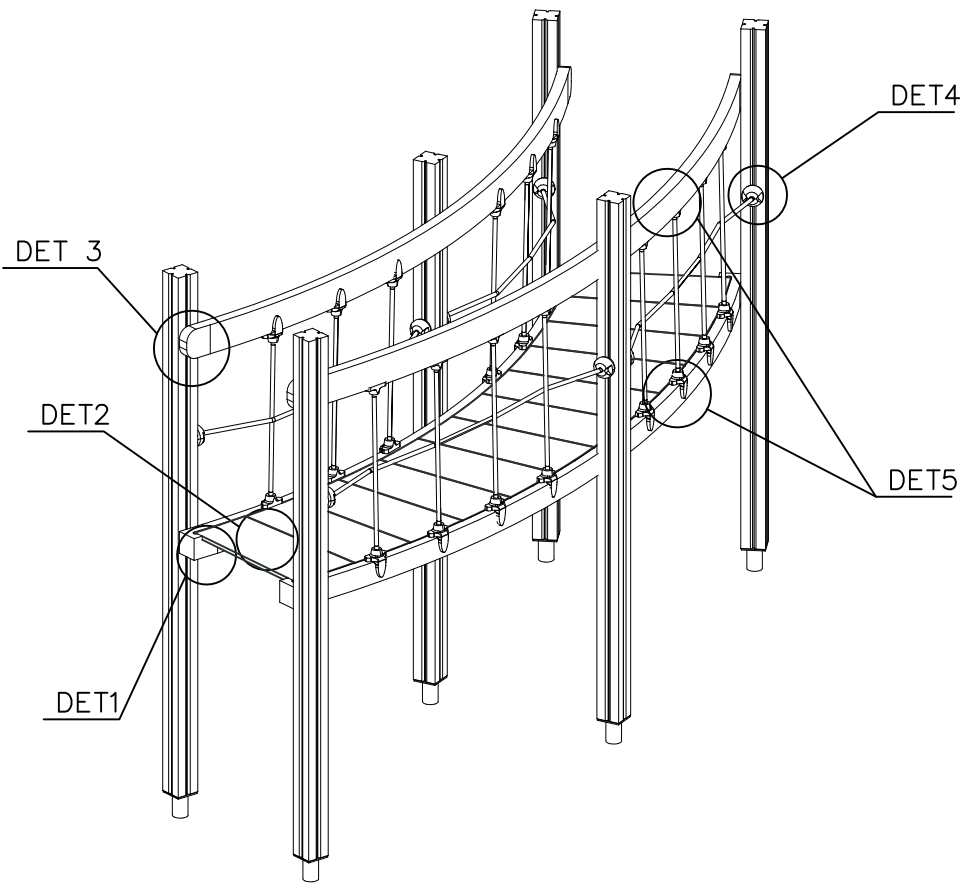

HUOM:

Täytä nestetila rauhallisesti alumiinille soveltuvan jäähdytysnesteen ja veden seoksella. Noudata seostuksessa jäähdytysnesteen valmistajan ohjeita paikallisiin pakkasolosuhteisiin. Nesteen kokonaismäärä on noin 30 L. Aloita lisäämällä nesteestä suurin osa, mutta jätä noin 5 litraa kokonaismäärästä lisäämättä. Lisää nestettä vähitellen vapauttaen liikkuva osa välillä nähdäksesi nousukorkeuden. Lisää nestettä kunnes liikkuva taso nousee annettuun korkeuteen tai hieman (1-3cm) korkeammalle. Kiinnitä laitteen kansi, suorita vähintään 10 koelaskua ja huuhtelee lopuksi laitteen runko mahdollisesti yliroiskuneesta nesteestä.

NOTE:

Fill the liquid chamber calmly with aluminium friendly radiator coolant and water. Follow the manufacturer's instructions for the formulation of coolant, taking into account local freezing conditions. The total volume is about 30 L. Start by adding the majority of the liquid, but leave approximately five (5) liters of space. Gradually add the remaining liquid while monitoring and releasing the moving part and taking care to ensure proper boom height. Add fluid until the level reaches a height that is level or slightly higher (1-3 cm) than given. Attach the cover and perform at least ten (10) test rides to ensure that equipment is functioning properly. Rinse and clean product to remove any residual fluid that may have been left behind.



①	900240	PCS	②	980123	PCS
		16			56
					
	Ø8x70			Ø7x60	
③	980128	PCS	④	980154	PCS
		76			12
					
	Ø7x40			Ø24/13	
⑤	909224	PCS	⑥	905090	PCS
		12			6
					
	12x100			Ø45	
⑦	905115	PCS	⑧	905103	PCS
		6			6
					
	Ø30			PT-28/32-H	
		PCS			PCS
		PCS			PCS
		PCS			PCS

DET 1

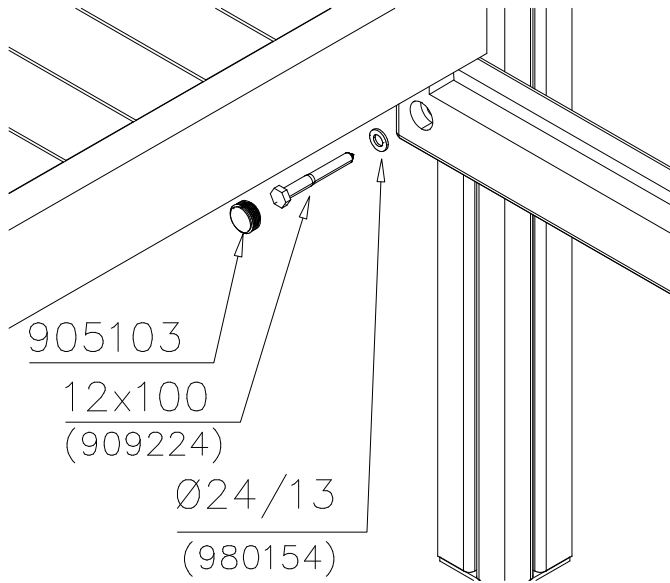

DET 2

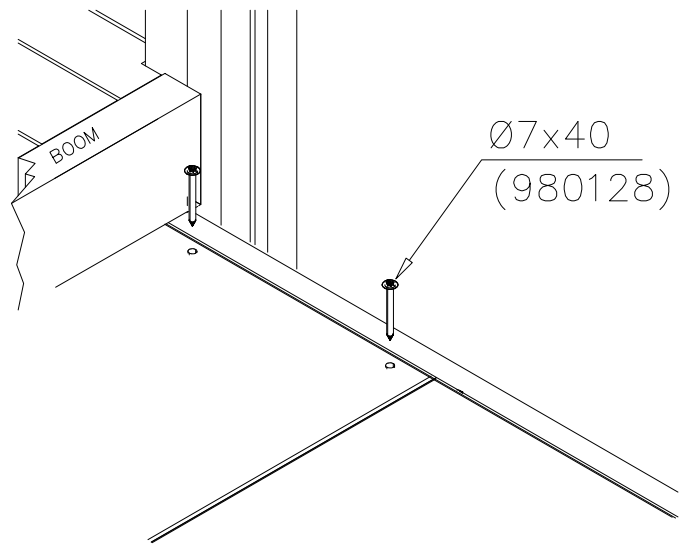

DET 3

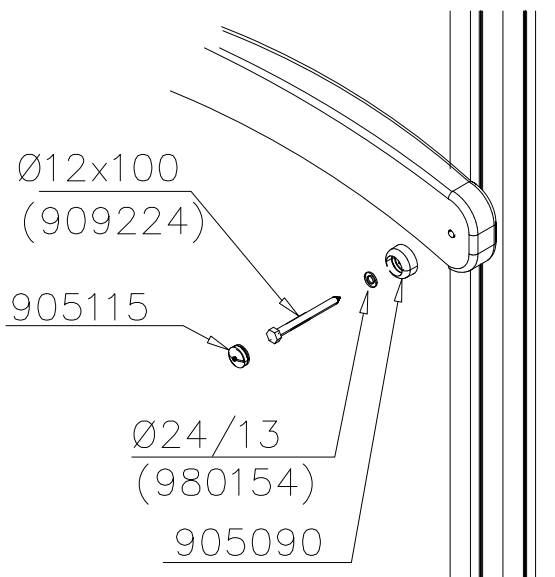

DET 4

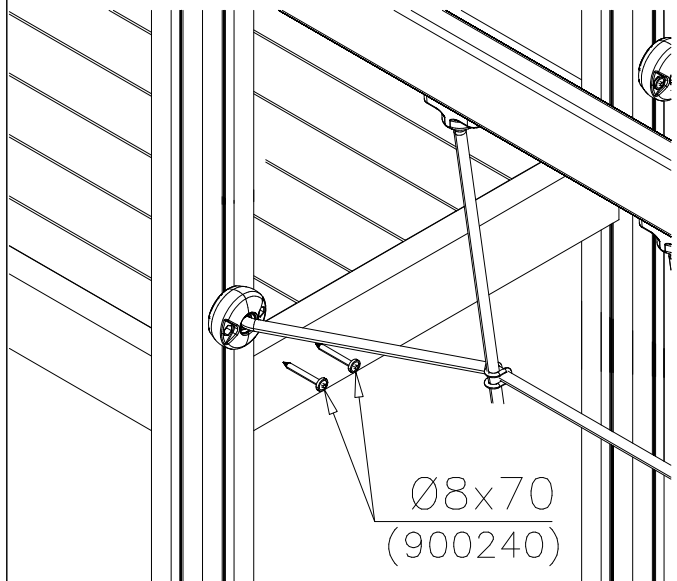

DET 5

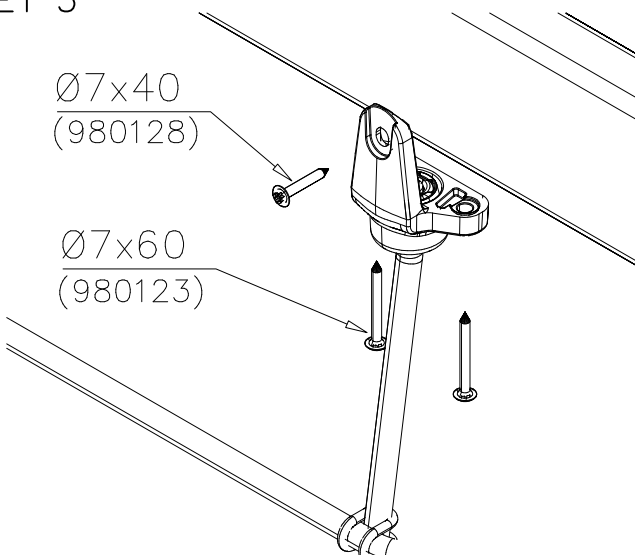

NET OPTIONS

707525

707528

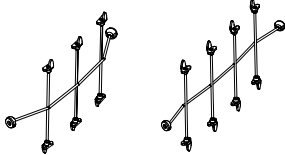

- 301 BLUE
- 302 RED
- 303 BEIGE
- 304 GRAY
- 305 BLACK

RAILING OPTIONS

707520

707521

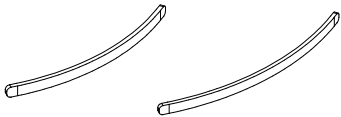

- 602 DARK BROWN
- 603 LIGHT BROWN
- 604 LIGHT GRAY
- 605 DARK GRAY
- 606 GRAY
- 607 RED
- 608 BLUE
- 609 GREEN
- 610 YELLOW
- 611 LIME
- 612 FUXIA

PLATE OPTIONS

707522

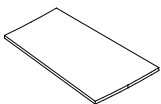

- 704 DARK GRAY

BOOM OPTIONS

707518

707519

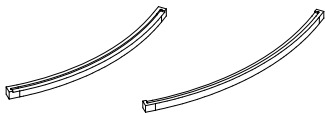

- 602 DARK BROWN
- 603 LIGHT BROWN
- 604 LIGHT GRAY

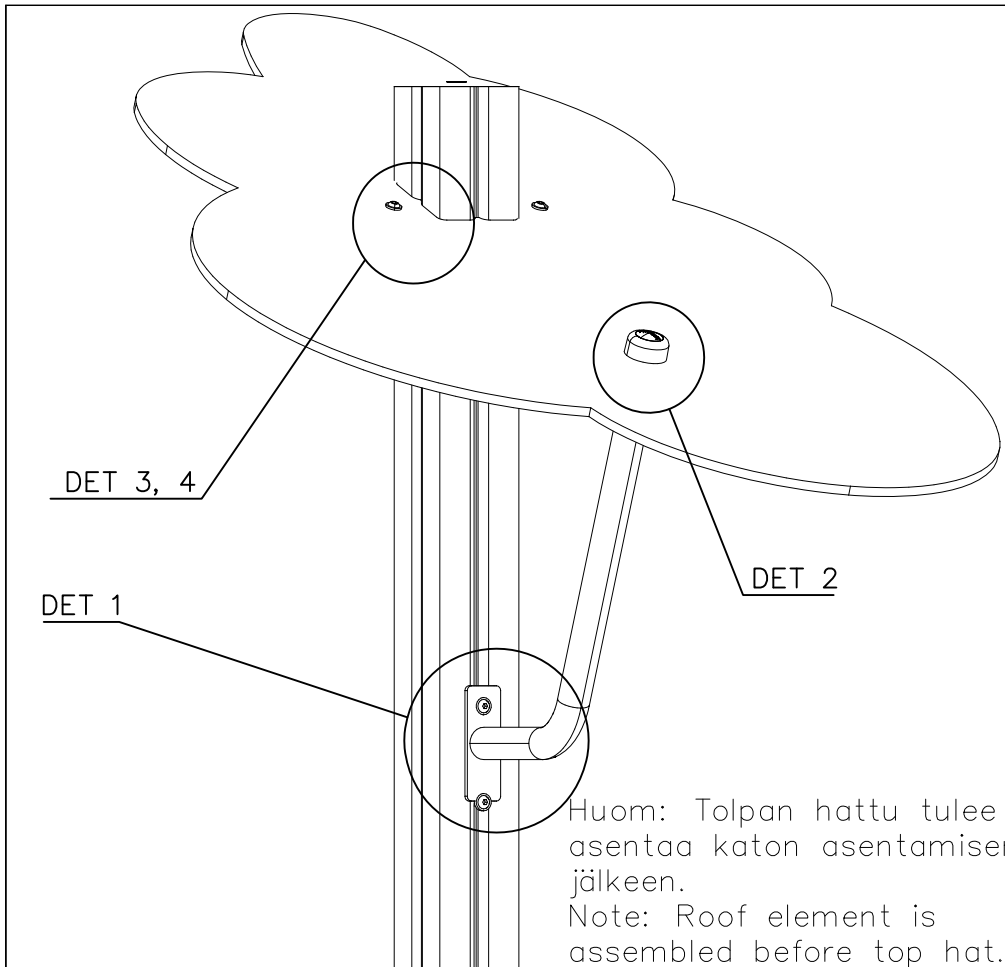

① 900240 Ø8x70	PCS 4	② 901570 36x55x55	PCS 2
③ 980154 Ø24/13	PCS 1	④ 905086 Ø44/13,5	PCS 1
⑤ 905090 Ø45	PCS 1	⑥ 905115 Ø30	PCS 1
⑦ 909142 M12x70	PCS 1	⑧ 980160 M8	PCS 2
⑨ 909852 M8x30	PCS 2		PCS
	PCS		PCS

DET 1

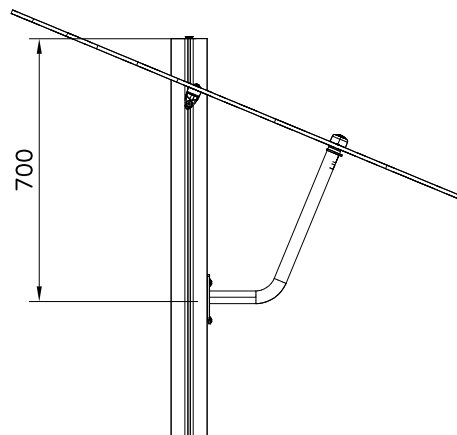
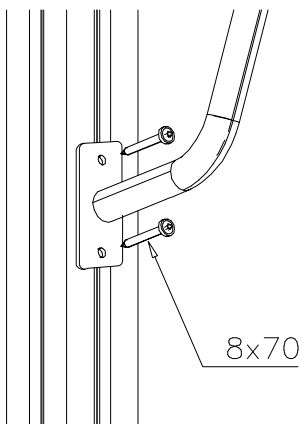

DET 2

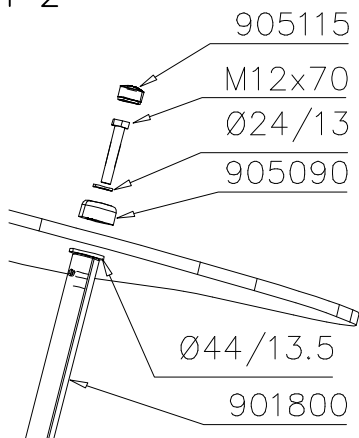



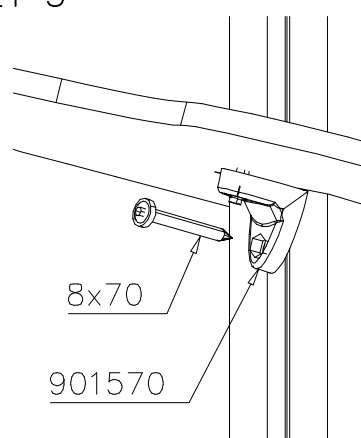



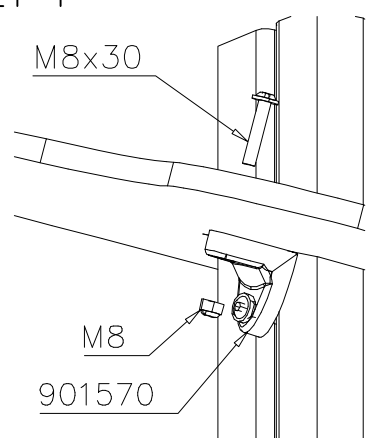

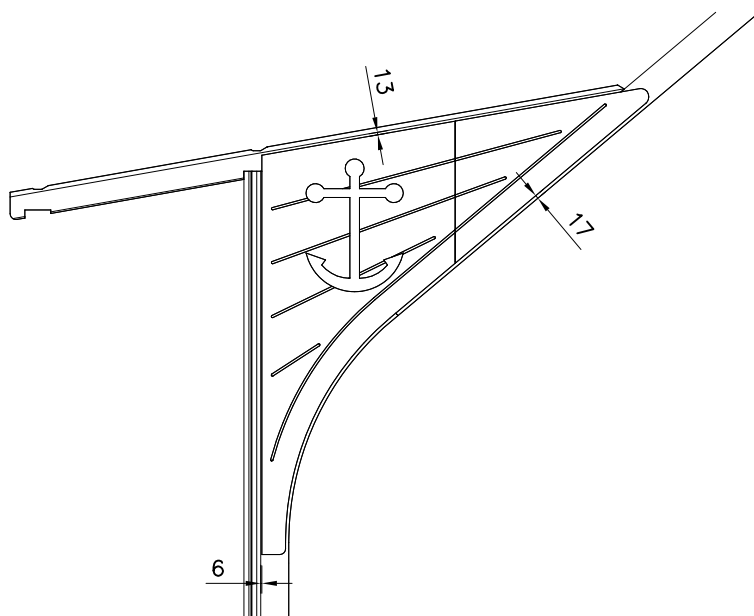
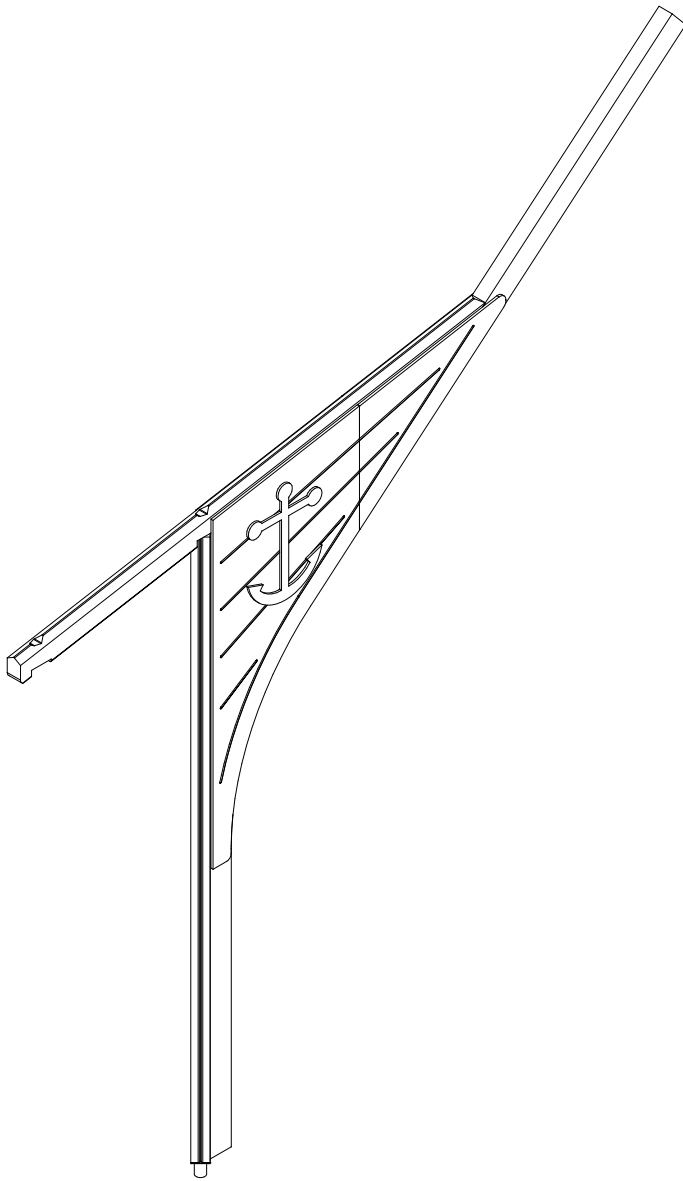



DET 3









DET 4

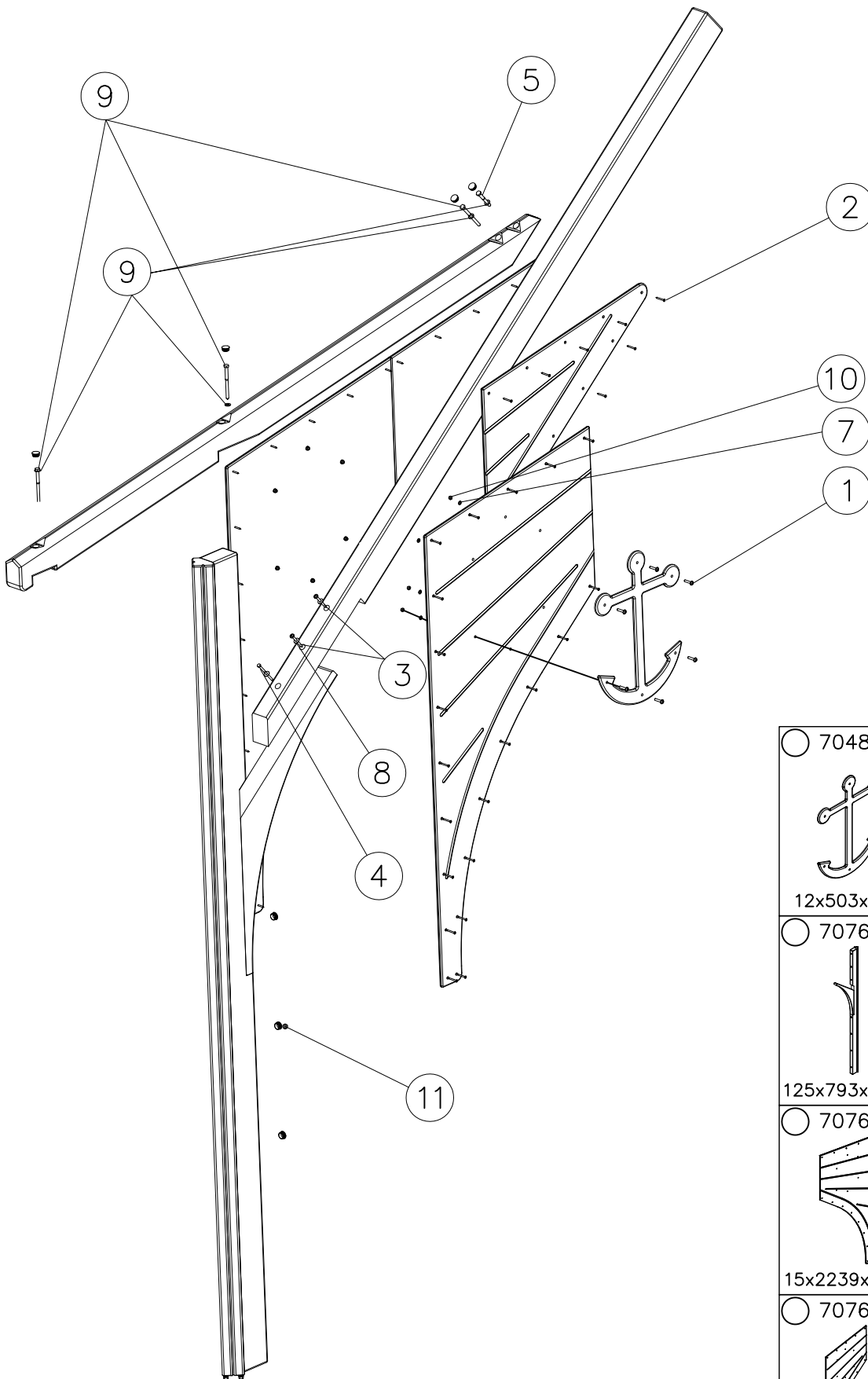



①	909876	PCS	②	902270	PCS
		12			62
					
	M8x40			Ø5x50	
③	903093	PCS	④	909232	PCS
		2			1
					
	Ø8x90			8x120	
⑤	909224	PCS	⑥	909222	PCS
		1			3
					
	12x100			12x150	
⑦	909256	PCS	⑧	905051	PCS
		12			3
					
	Ø16/8.4			Ø24/8.4	
⑨	980154	PCS	⑩	980160	PCS
		4			12
					
	Ø24/13			M8	
⑪	905103	PCS			PCS
		8			
					
	PT-28/32-H				
		PCS			PCS
		PCS			PCS

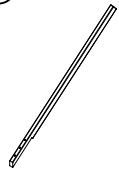

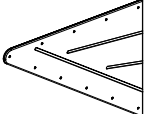
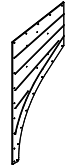
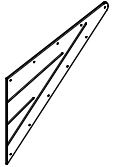
○ 704868	PCS	○ 707634	PCS
	2		1
12x503x687		90x145x3233	
○ 707643	PCS	○ 707646	PCS
	1		1
125x793x3700		90x145x4073	
○ 707657	PCS	○ 707658	PCS
	1		1
15x2239x1000		15x1000x721	
○ 707660	PCS	○ 707661	PCS
	1		1
15x2239x1000		15x1000x721	

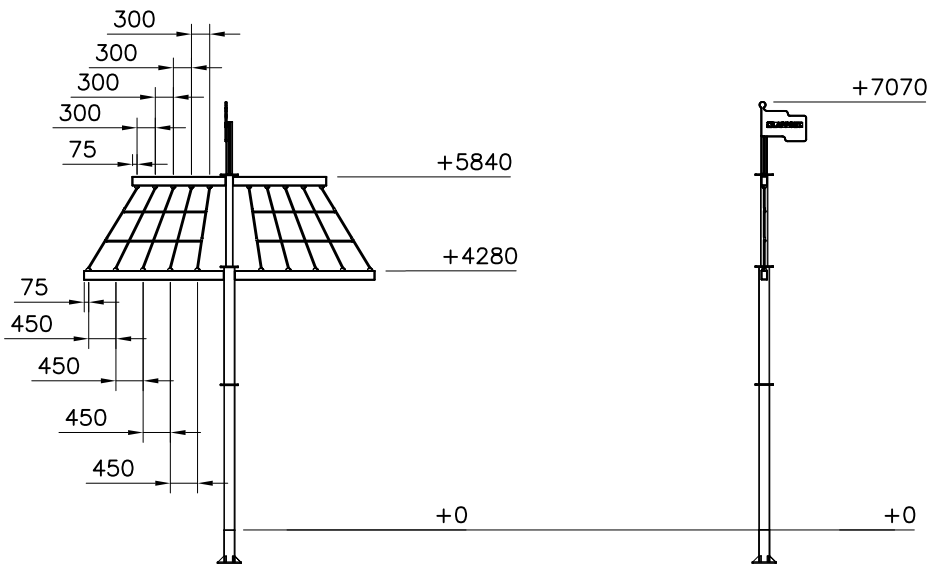
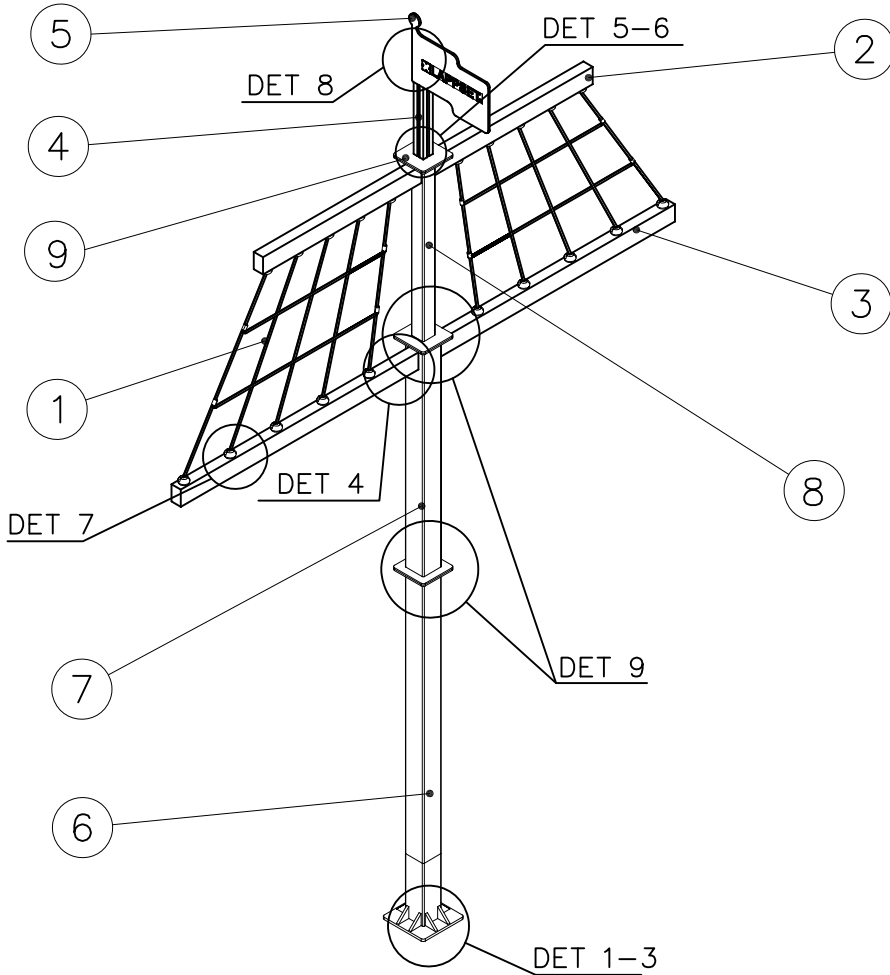

① 707485	PCS	② 707482	PCS
	2		2
		90x145x1540	
③ 707483	PCS	④ 706499	PCS
	2		1
90x145x2310		L 860	
⑤ 007969	PCS	⑥ 908228	PCS
	1		1
		L 2950	
⑦ 908231	PCS	⑧ 908232	PCS
	1		1
L 1950		L 1520	
⑨ 929830	PCS	⑩ 903093	PCS
	1		3
300x300		Ø8x90	
⑪ 900240	PCS	⑫ 909649	PCS
	40		8
Ø8x70		HPM 24/L	
⑬ 009928	PCS	⑭ 929917	PCS
	1		20
600x600		M20x50	
⑮ 909859	PCS	⑯ 929918	PCS
	40		20
ø37/21		M20	

DET 1

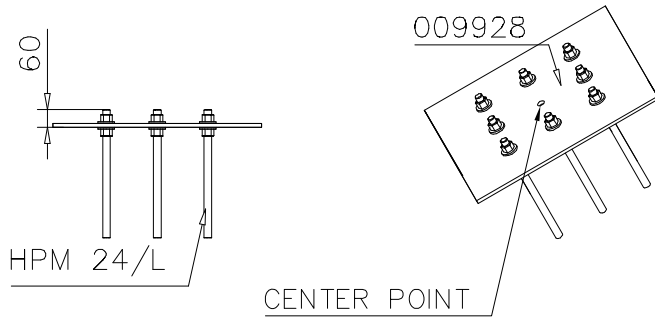

PCS		PCS

PCS		PCS

DET 2

CONCRETE PLATE SOLUTION

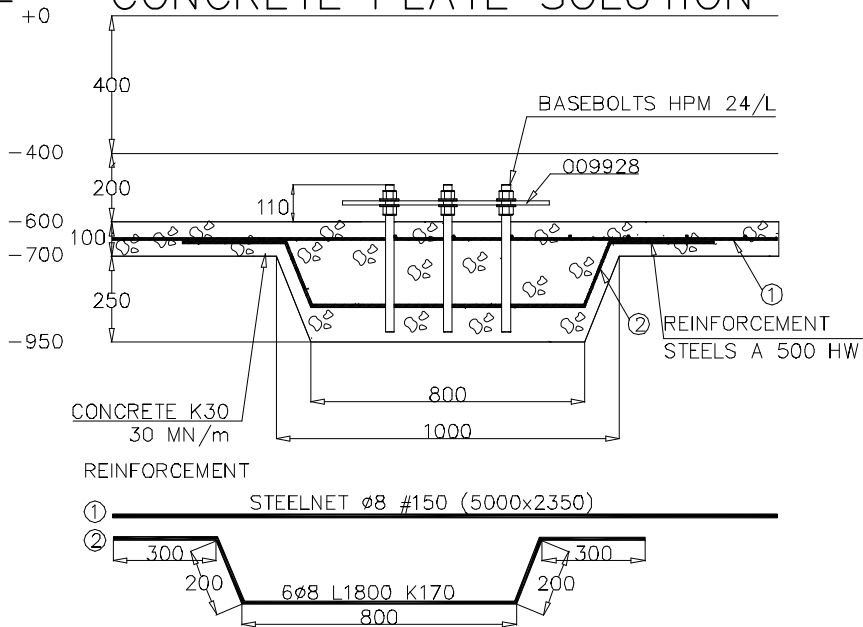

PCS		PCS

PCS		PCS

PCS		PCS

DET 3

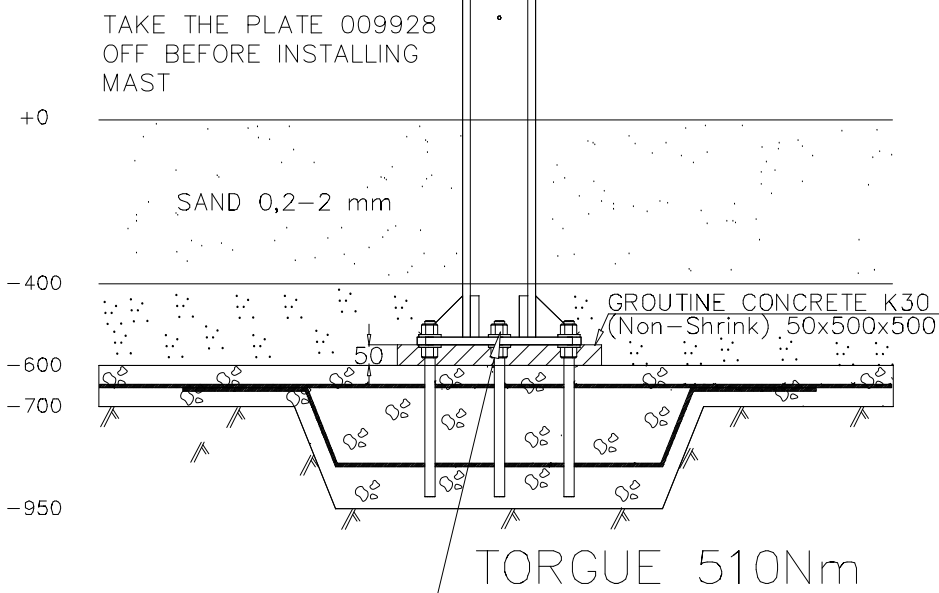

PCS		PCS

PCS		PCS

PCS		PCS

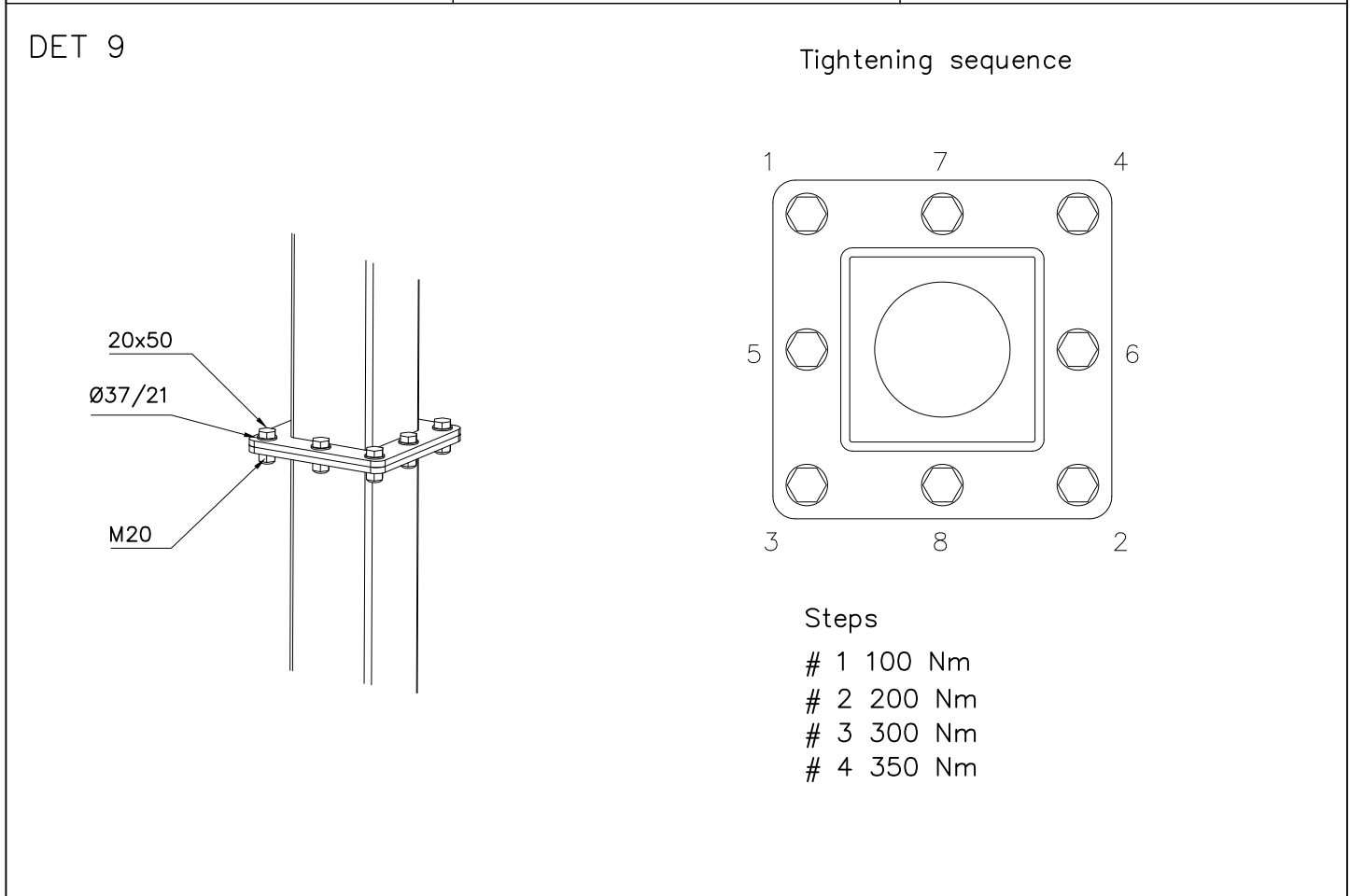
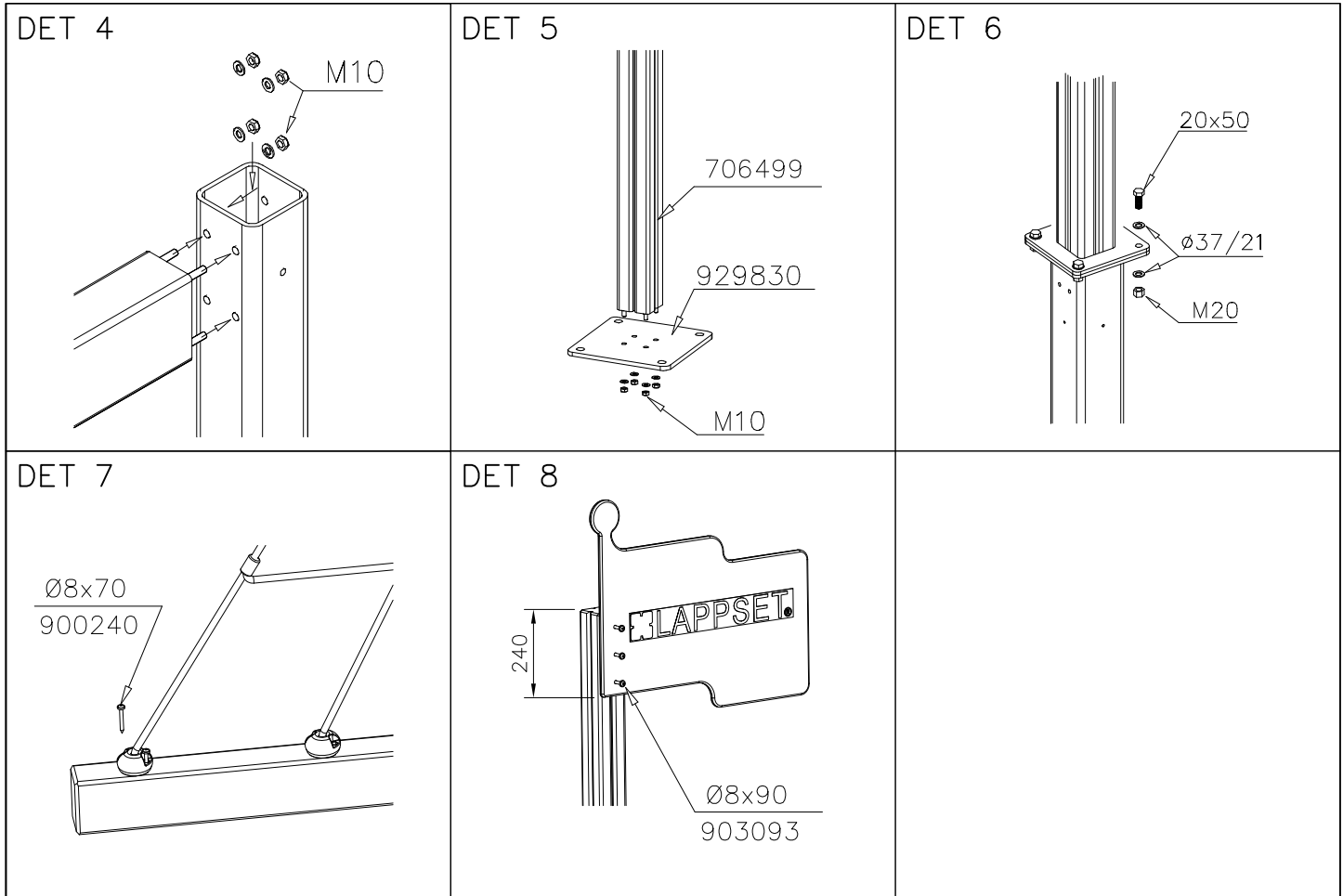

OPTION CONCRETE BLOCK SOLUTION

DET 2

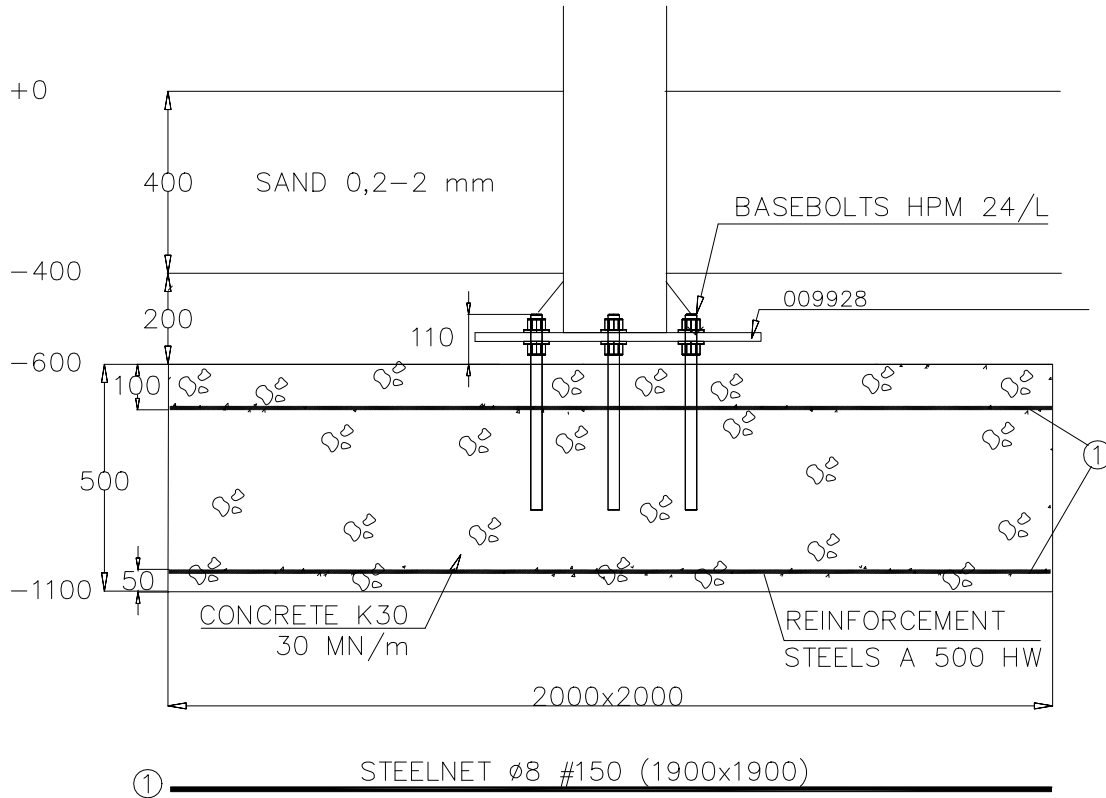

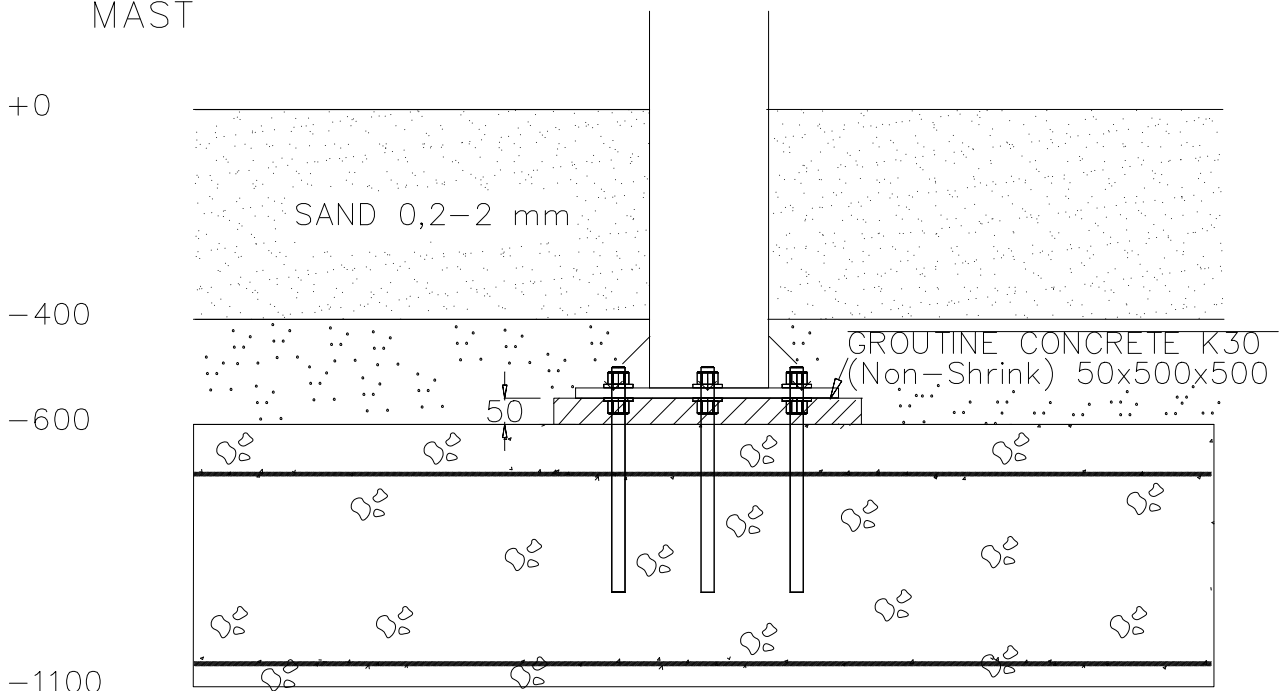

DET 3

TAKE THE PLATE 009928
OFF BEFORE INSTALLING
MAST

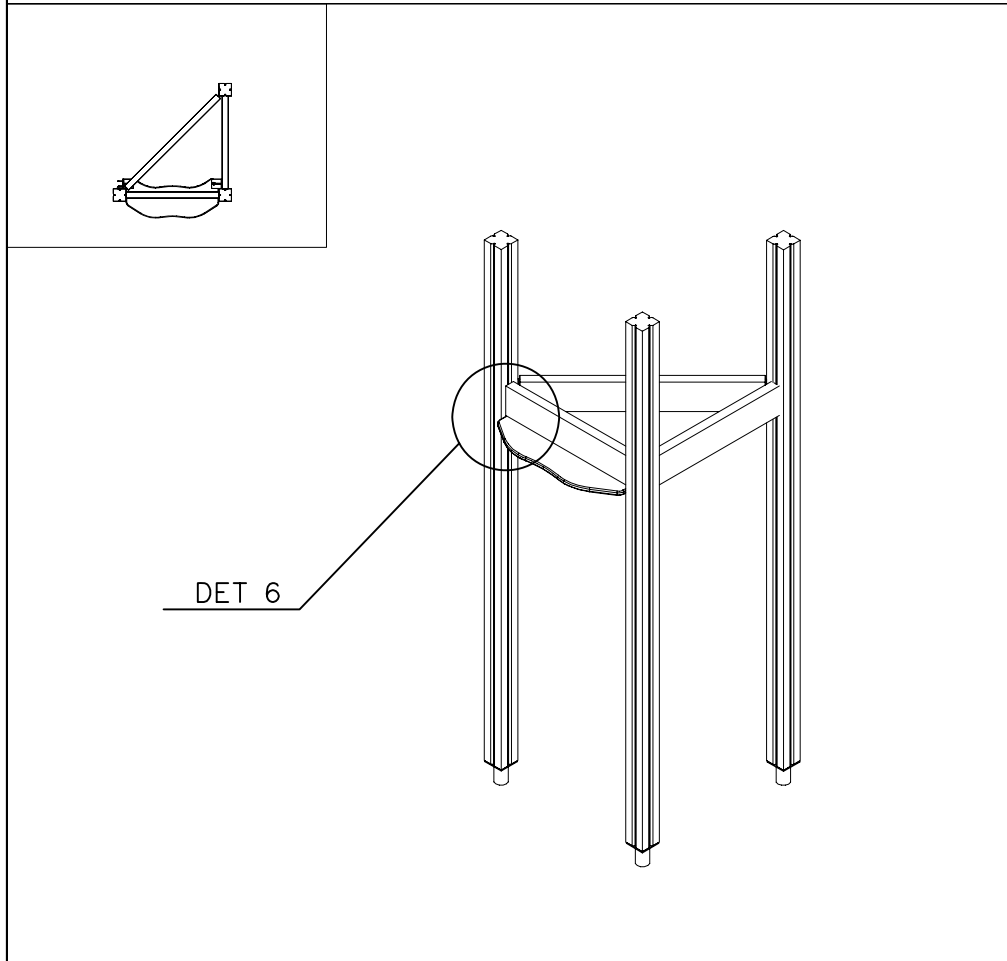
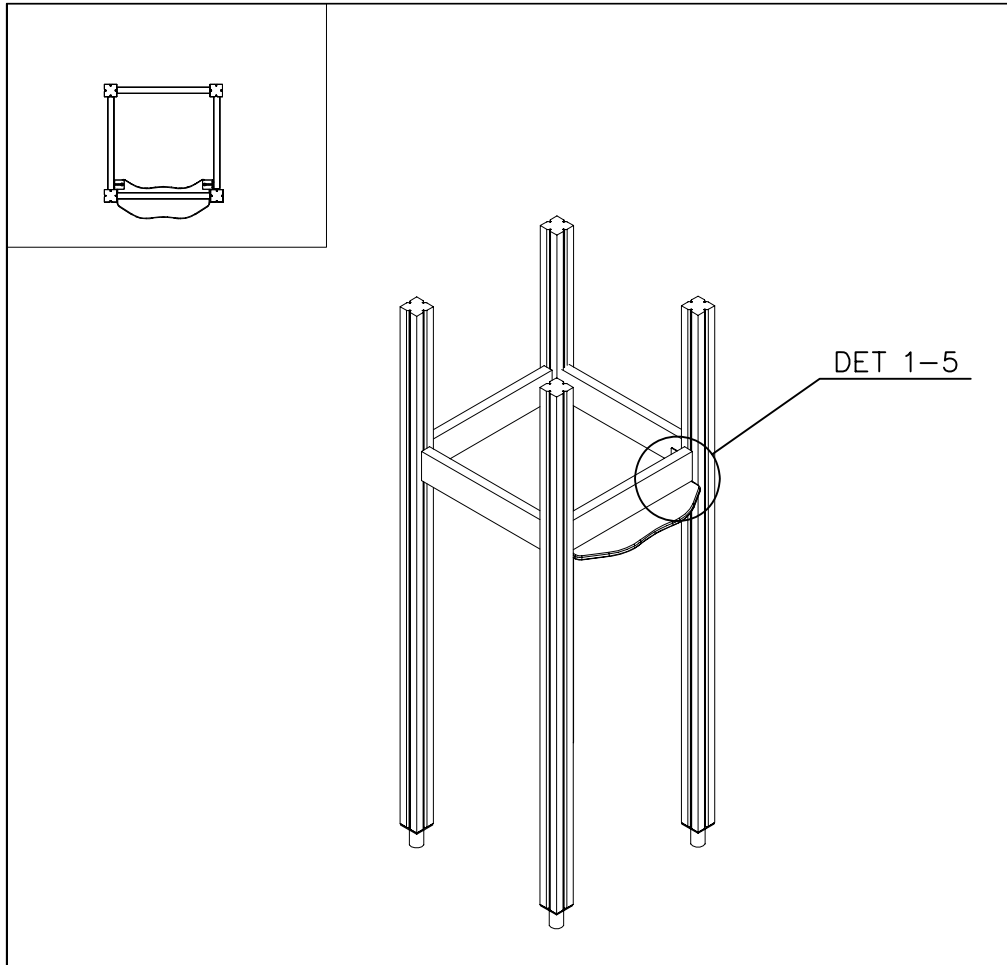

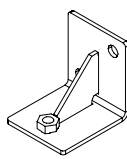
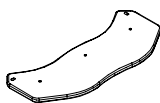
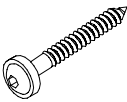
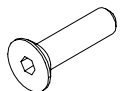

① 904281	PCS	② 703774	PCS
	2		1
③ 900240	PCS	④ 901487	PCS
	4		2
Ø8x70		M10x40	
⑤ 903236	PCS	⑥ 980128	PCS
	1		4
Ø30/10.5		Ø7x40	
	PCS		PCS
	PCS		PCS
	PCS		PCS
	PCS		PCS

DET 1

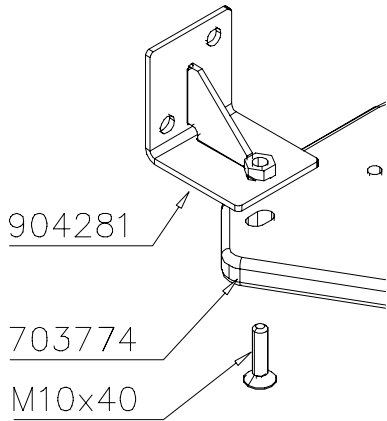

DET 2

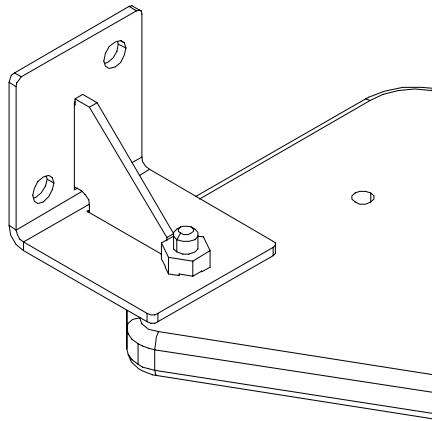

DET 3

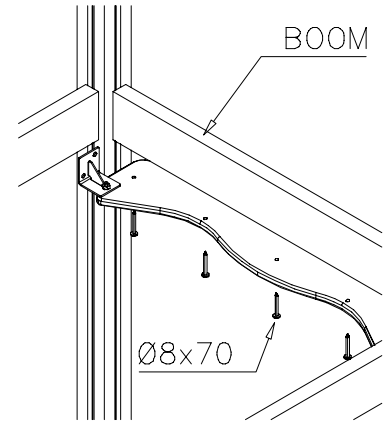

DET 4

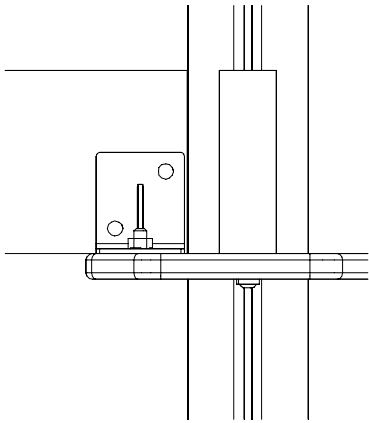

DET 5

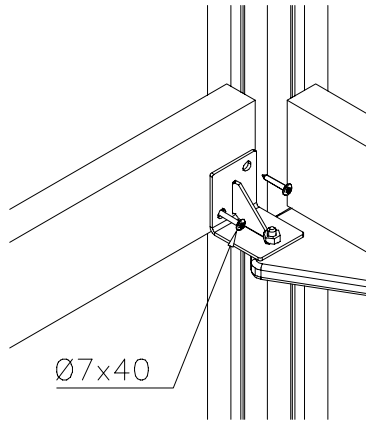

DET 6

