

ASENNUSOHJE

Kuutiot 908871, 908872, 908873, 908874, 908875, 908876, 908877, 908878, 908879, 908880, 908881, 908882, 908883, 908884

Päivitetty: 1.3.2018

ALUSTAVAATIMUKSET

Alustan on oltava routimaton ja tasainen.

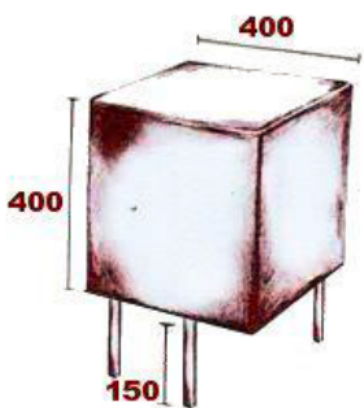

ASENNUS

Asenna EUROFLEX®-kuutio paikoilleen työntämällä lisävarusteena toimitettavat teräsankkurit tukevalle alustalle valettuun tuoreeseen betonivaluun (lujuusluokka C12/15).

Kuutiot voidaan myös liimata EUROFLEX®-laattoihin tai vastaavaan kumialustaan.



Auringonvalon aiheuttamien värvirheiden välttämiseksi jätä tuotteen UV-suojakalvo paikoilleen asennushetkeen asti.

© Lappset Group Oy. Kaikki oikeudet pidätetään.

Viimeisin tieto löytyy: <https://www.kraiburg-relastec.com/euroflex/en/playground-accessories/>
LAPPSET GROUP OY PL 8146 | 96101 Rovaniemi | 0207 750 150 | myynti@lappset.com | www.lappset.fi

Substructure

The substructure must be frost-stable and level.

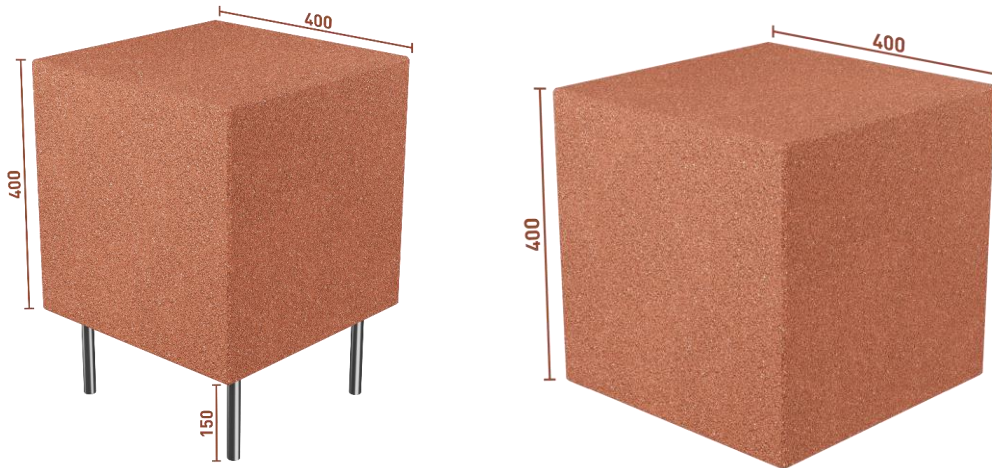

Installation

The EUROFLEX® cubes with the 4 pressed-in ground anchors can be placed on one load-bearing compacted substructure directly into a prepared fresh concrete bed (C12 / 15) to be installed.

Cubes without ground anchors can placed on EUROFLEX® fall protection slabs or corresponding in-situ surfaces are glued.



All information without guarantee, subject to change. The installation instruction is not subject to any change service. Each current and valid from can be recalled at www.kraiburg-relastec.com/euroflex/



To avoid colour variations due to differences in sunlight exposure, leave the UV protection film on the product as supplied until just prior to installation.

Gluing instructions

Glue requirement: 1 cartridge for 2 cubes full-surface gluing

Adhesive:

We recommend the adhesive Ottocoll P83 (gray) or Ottocoll M 500 (red), which can be obtained from us. The warranty is void if other adhesives that have not been tested are used.

Work preparation:

The surfaces must be clean, dry and free of grease.

Gluing: Apply the material from the glue gun to the substrate. The application thickness depends on the nature of the materials to be bonded. Insert the counter material within 10 minutes and press it on. The curing depends on the layer thickness and the humidity.

Processing temperature: + 5 ° C - + 40 ° C, skin formation time at 23 ° C: approx. 20 minutes, Hardening time at 23 ° C: approx. 24 hours