

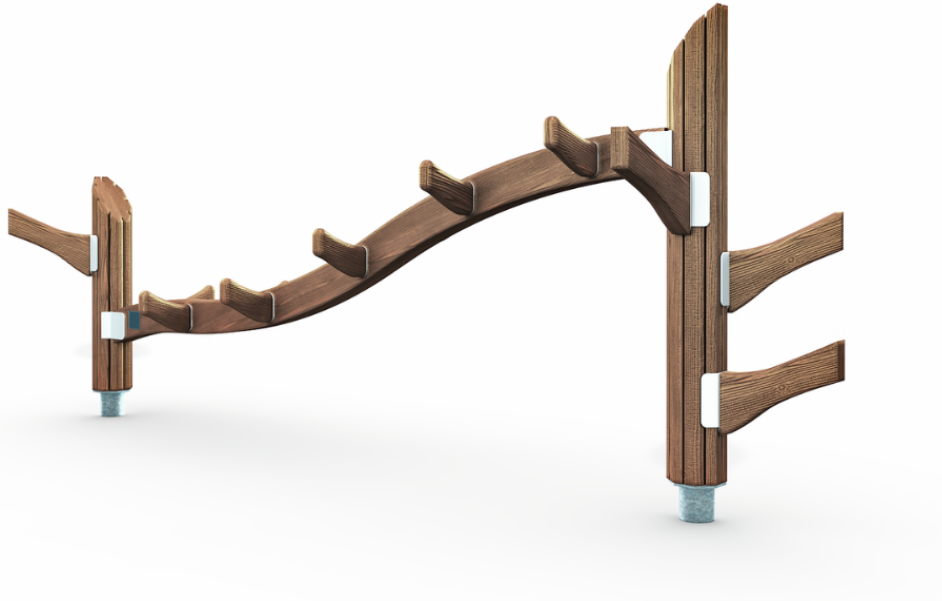

GIANT'S COMB (ASTM)

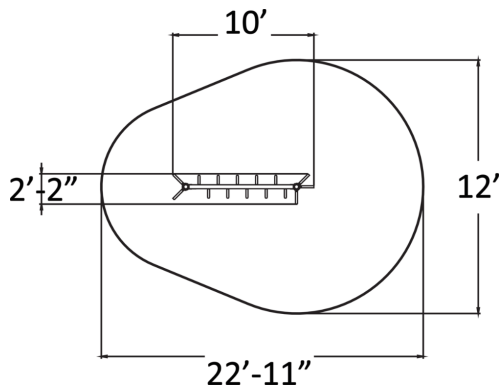

The US175591 product complies with the ASTM Standard. The Giant's comb is a balancing track which can be placed on a trail in many ways, having the starting point either on the lower or the taller end. This kind of equipment is ideal for school yards for exercise and motor skills improvement, but also as a substitute of traditional seating. Whilst the equipment invites to sit, it promotes "exercise in disguise" whilst hanging out with friends. The Giant's comb is over 9 feet long balancing track with a wave shaped, ascending beam with ten branches, supported by a post at both ends.



User age	5-12
Number of users	5
Product length, mm	3060
Product width, mm	660
Product height, mm	1300
Height required, mm	2900
Max. free fall height, mm	900
Safety info	ASTM F1487-17
Installation time (for 1), H	2
Wood	
Metal	