

# Forest Elf's Swing (ASTM)

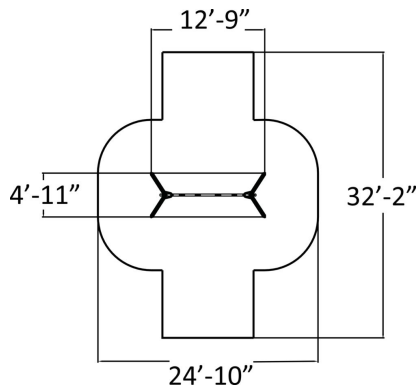

The US175575 product complies with the ASTM Standard. The Forest Elf's Swing is a perennial favourite among kids, offering thrilling speed! The lovely swing fits beautifully into its natural background.



Number of users	2
Product length, mm	3960
Product width, mm	1570
Product height, mm	2850
Height required, mm	2700
Max. free fall height, mm	2450
Safety info	ASTM F1487-17
Installation time (for 1), H	6
Wood	
Metal	