

WOBBLING LOGS (ASTM)

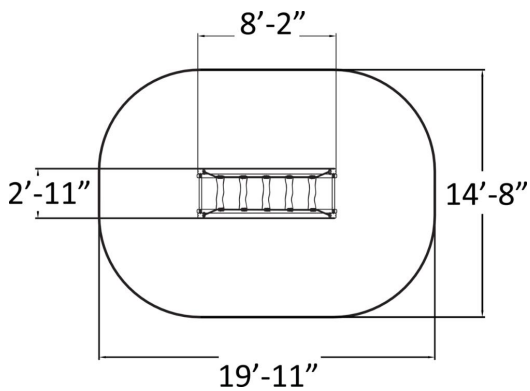

The US175533 product complies with the ASTM Standard. The Wobbling logs improves balance, coordination, core body strength and lower body strength. This equipment is an arched rung bridge with five rungs suspended by ropes from the arched handrails. The unsteady steps rise along the handrail curve and move back and forward, side to side, providing an exciting challenge for wide range of users.



User age	2-12
Number of users	7
Product length, mm	2490
Product width, mm	890
Product height, mm	1100
Height required, mm	2120
Max. free fall height, mm	380
Safety info	ASTM F1487-17
Installation time (for 1), H	2