

NA175593M

Fish Trap (ASTM CSA)

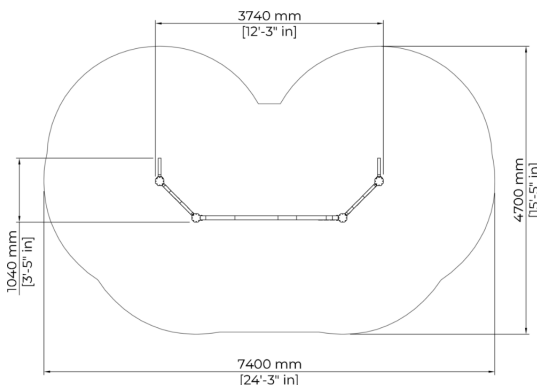

Fish Trap (NA175593M) complies with the ASTM and CSA standards. Let's go fishing with the trolls! The fish trap is a climbing equipment that provides more challenge than meets the eye at first. The asymmetrically arranged ropes provide good exercise for balance, body strength and spatial awareness. The ropes are "living" elements and responsive to every movement. Climbing on the equipment is challenging but fun – whether played alone or with friends. The Fish trap is a climbing equipment which consists of two "ladders" supporting a climbing net in the middle. The ropes in the climbing structure are placed asymmetrically. There is a horizontal beam above the net. Two branches on each outer post help getting onto the ladder.

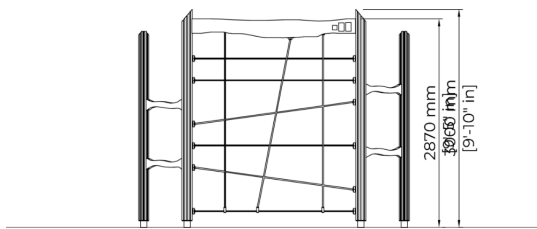

Number of users	12
Product length, mm	3740
Product width, mm	1040
Product height, mm	3000
Height required, mm	4500
Safety info	ASTM F1487, CSA Z614
Installation time (for 1), H	5
Foundation options	deep_mounting surface_mounting
Wood	
Ropes	