

175593M
Fish trap

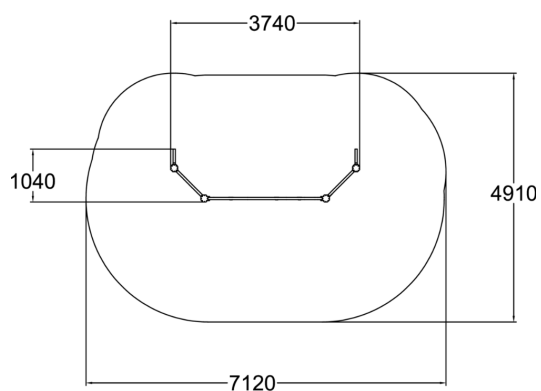

Let's go fishing with the trolls! The fish trap is a climbing equipment that provides more challenge than meets the eye at first. The asymmetrically arranged ropes provide good exercise for balance, body strength and spatial awareness. The ropes are "living" elements and responsive to every movement. Climbing on the equipment is challenging but fun - whether played alone or with friends. The Fish trap is a climbing equipment which consists of two "ladders" supporting a climbing net in the middle. The ropes in the climbing structure are placed asymmetrically. There is a horizontal beam above the net. Two branches on each outer post help getting onto the ladder. The product is manufactured from locally sourced nordic pine. Available in Natural Tone and Flora Brown.

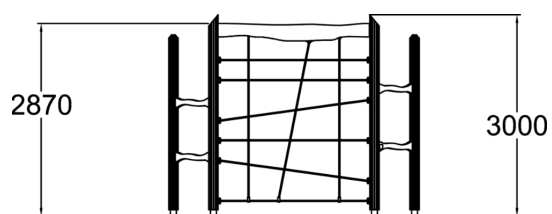

User age	6+
Number of users	12
Product length, mm	3740
Product width, mm	1040
Product height, mm	3000
Impact area, m ²	30.6
Falling space, m ²	30.6
Height required, mm	4500
Max. free fall height, mm	2870
Safety info	EN 1176-1:2008
Installation time (for 1), H	5
Foundation options	deep_mounting surface_mounting
Wood	
Ropes	