

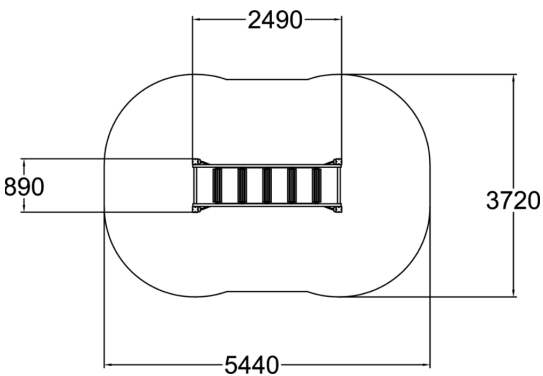

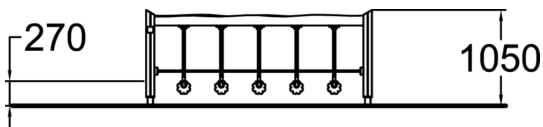

The Rolling logs improves balance, coordination as well as core & lower body strength. It is fun for the player to use, as well as for the possible bystander to watch! This equipment is a bridge with five rounded logs suspended by ropes from the handrails. The logs rotate back and forward.



| | |
|-------------------------------|---|
| User age | 3+ |
| Number of users | 7 |
| Product length, mm | 2490 |
| Product width, mm | 890 |
| Product height, mm | 950 |
| Falling space, m ² | 18.1 |
| Height required, mm | 1970 |
| Max. free fall height, mm | 270 |
| Safety info | EN 1176-1 TÜV |
| Installation time (for 1), H | 2 |
| Foundation options | deep_mounting |
| Wood |  |
| Ropes |  |