

Chinning Bars for 2

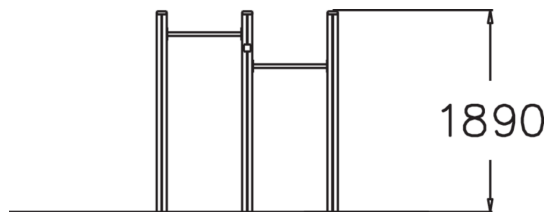

The equipment consists of three vertical posts with two bars at different heights. The Chinning bars can be used for chin-ups, as well as leg lifts that exercise the core muscles. The total height is 1740 mm.

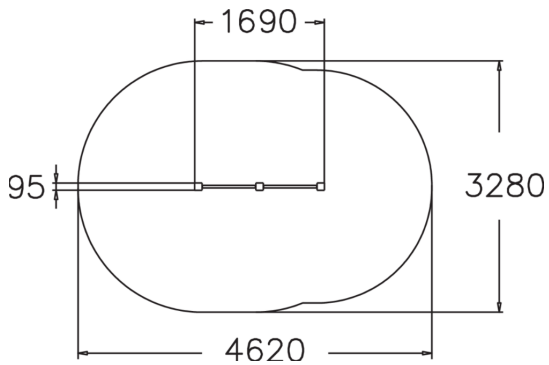

User age	5+
Number of users	2
Product length, mm	1690
Product width, mm	95
Product height, mm	1890
Impact area, m ²	12.6
Falling space, m ²	12.6
Height required, mm	1980
Max. free fall height, mm	1680
Safety info	EN 1176-1 TÜV
Installation time (for 1), H	1
Foundation options	deep_mounting
Wood	<input checked="" type="checkbox"/>
Metal	<input type="checkbox"/>