

Sand Crane

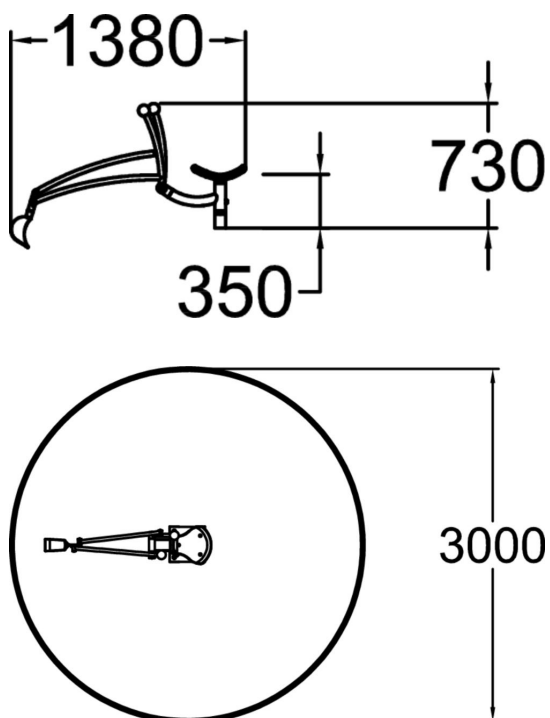

Stainless steel sand crane rotates 360° and transports a shovel-full of sand from right to left—to build a tower for a little princess or to dig a castle moat. Made of high-quality EPDM rubber, the seat is comfortable, soft and warm in both summer and winter. The excavator has its own falling space, and has an impact attenuation requirement corresponding to the falling height of the seat. Placed in a sandbox, the excavator and sandbox form a natural cluster as defined in EN 1176-1 clause 3.20, meaning they are viewed as a single equipment. The fall height difference from the excavator to the edge of the sandbox is acceptable, but it is important to ensure that the sand box has rounded edges.



User age	3+
Number of users	1
Product length, mm	1380
Product width, mm	330
Product height, mm	730
Impact area, m ²	7.1
Falling space, m ²	9.4
Height required, mm	1850
Max. free fall height, mm	350
Installation time (for 1), H	2
Foundation options	deep_mounting
Metal	