

Sisu Back extension

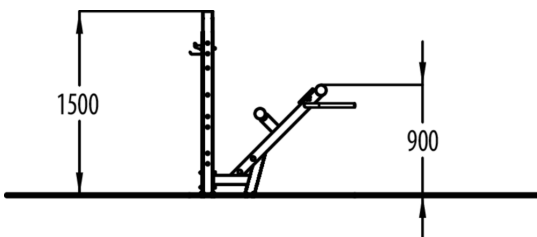

Sisu Back extension -equipment is designed to strengthen the muscles of the lower back. Back extension bench can be used for different variations of back exercises: dynamic extensions, static holds or for movements with or without rotation. A rack for a drink bottle and for hanging clothes is included.

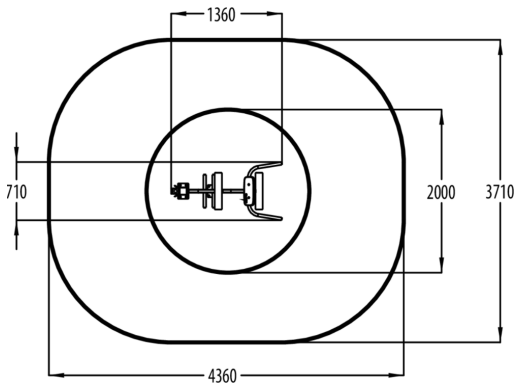

Number of users	1
Product length, mm	1360
Product width, mm	710
Product height, mm	1510
Height required, mm	2000
Max. free fall height, mm	900
Safety info	EN 16630 TÜV
Installation time (for 1), H	2
Foundation options	surface_mounting
Metal	
Colour of walls and HPL	