

# FINGER STAIRS

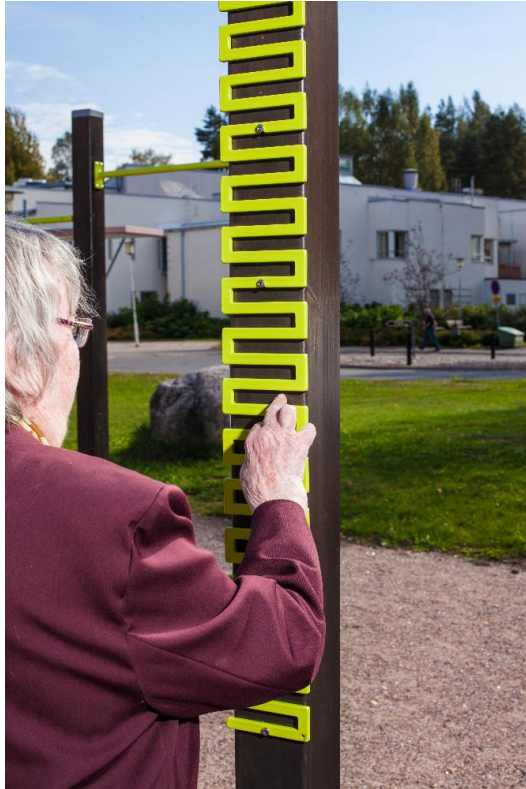

Fitness equipment intended for seniors, consisting of a beam with metal "stairs" for practising finger dexterity. The total height is 2,125 mm. This works the fingers, elbows and shoulders. The wide range of motion helps to develop hand-eye coordination and concentration. These two abilities are needed in everyday life, for example in using a phone or opening food containers.

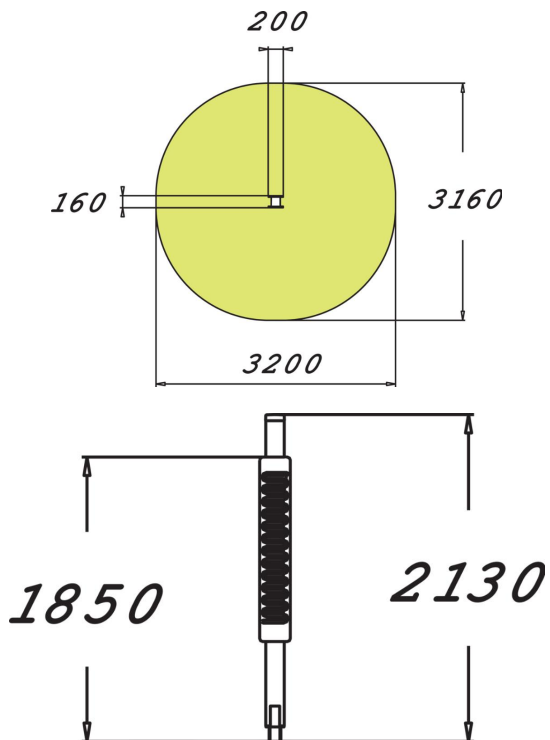

Product length, mm	130
Product width, mm	130
Product height, mm	2125
Safety info	EN 16630, EN 1176-1 TÜV
Installation time (for 1), H	2
Foundation options	Deep mounting Surface mounting