

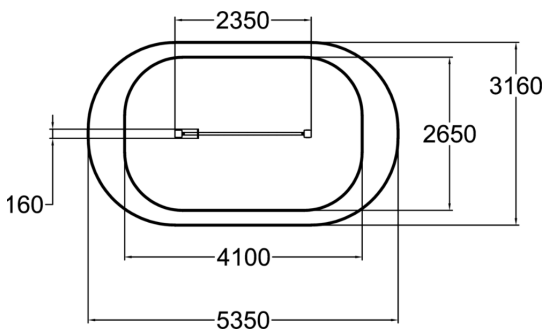

Fitness equipment intended for seniors, consisting of two uprights holding a curved metal bar with a laminate ring. The highest point of the bar is 1,290 mm high. The idea is to slide the ring from one end of the bar to the other without touching the bar. This provides exercise for the wrist, elbow and shoulder joints. The wide range of motion helps to develop hand-eye coordination and concentration. These two abilities are needed in everyday life, for example in using a phone or opening food containers.

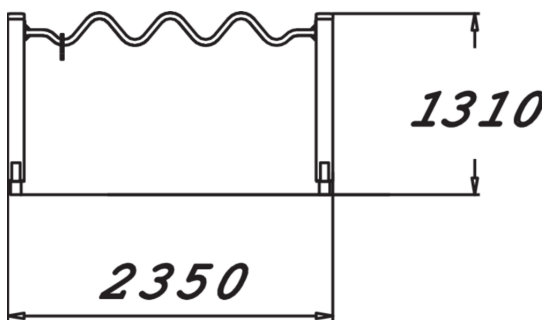

Product length, mm	2350
Product width, mm	160
Product height, mm	1310
Safety info	EN 16630, EN 1176-1 TÜV
Installation time (for 1), H	4
Foundation options	deep_mounting surface_mounting
Wood	
Metal	