

Fitness equipment intended for seniors, consisting of two uprights holding a wavy metal bar with a laminate ring. The highest point of the bar is 1,395 mm high. The idea is to slide the ring from one end of the bar to the other without touching the bar. This provides exercise for the wrist, elbow and shoulder joints. The wide range of motion helps to develop hand-eye coordination and concentration. These two abilities are needed in everyday life, for example in using a phone or opening food containers.

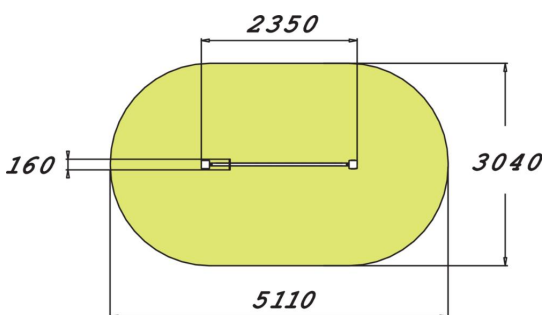
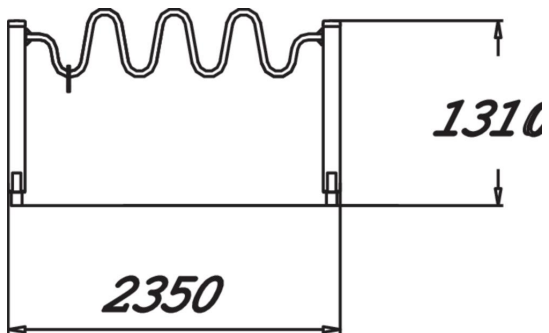

| | |
|------------------------------|-----------------------------------|
| Product length, mm | 2350 |
| Product width, mm | 160 |
| Product height, mm | 1395 |
| Safety info | EN 16630, EN 1176-1 TÜV |
| Installation time (for 1), H | 4 |
| Foundation options | deep_mounting surface_mounting |
| Wood | |
| Metal | |