

BATTLING ROPES

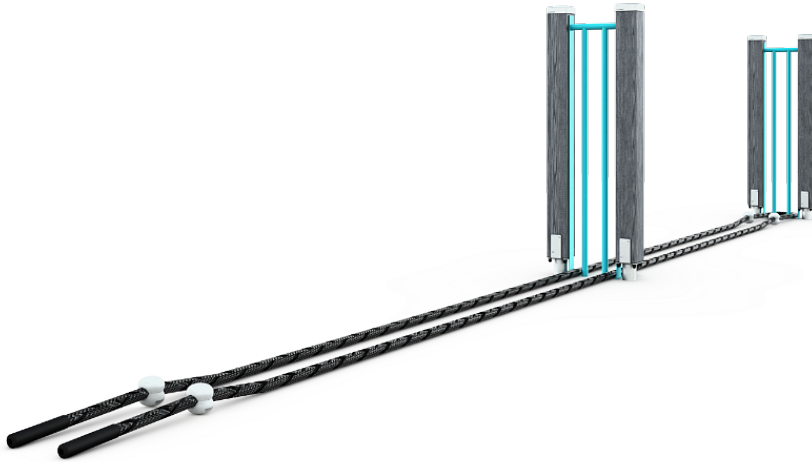

The Battling Ropes consist of two stands and two ropes passing through the stands. This is a functional piece of equipment that allows the ropes to be moved simultaneously or in an alternating rhythm. The more holistically the body is used for moving the ropes, the more effective the exercise. The exercise can be varied by combining it with squats or raised push-ups, for example. Pulling the ropes is particularly effective for training the respiratory and circulatory systems.

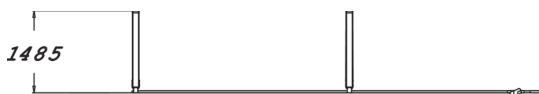
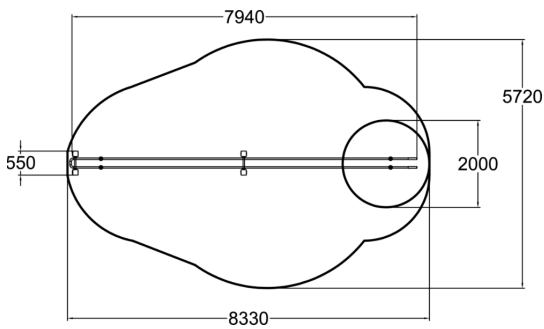

Product length, mm	7940
Product width, mm	550
Product height, mm	1485
Safety info	EN 16630, EN 1176-1 TÜV
Installation time (for 1), H	3
Foundation options	deep_mounting surface_mounting
Wood	
Metal	
Ropes	