

MONKEY BARS

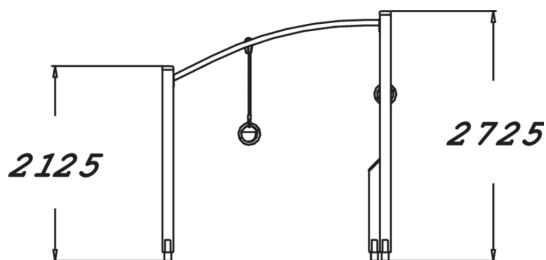

The Monkey Bars include gymnastic rings at two different heights, joined together by monkey bars. One end is higher than the other, for a total height of 2,725 mm. The rings are movable to make the equipment suitable for exercisers of different heights. It also makes it possible for children and adults to enjoy exercising together. The set is suitable for ring dips, chin-ups and ring chin-ups. Body control can be improved with various static holds such as L-holds or chin-up holds. The ladder can be used for climbing with or without feet. The monkey bars are excellent for diverse upper-body and core exercises.

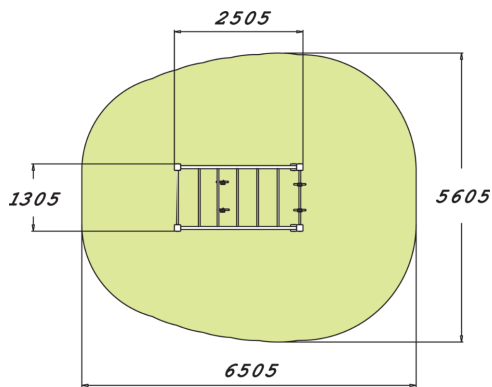

Number of users	3
Product length, mm	2505
Product width, mm	1305
Product height, mm	2725
Impact area, m ²	30.7
Height required, mm	2930
Max. free fall height, mm	2620
Safety info	EN 16630, EN 1176-1 TÜV
Installation time (for 1), H	6
Foundation options	deep_mounting surface_mounting
Wood	
Metal	