

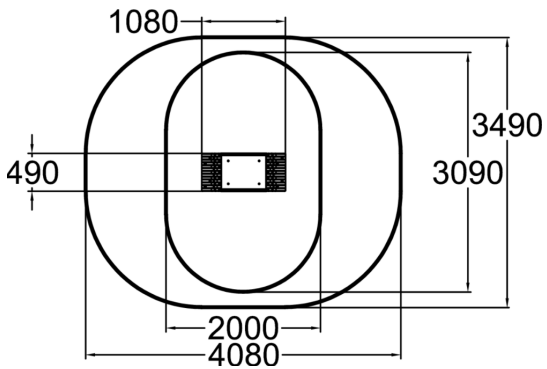

450 mm high box for medium-height jumps. The box can be used for either high-speed jumps or slower stepping. Jumping raises the heart rate and strengthens the leg muscles and bones. Keep the weight on the heels, with the lower leg as vertical as possible and pushing the knees outward at all times. The box can also be used for raised push-ups and dips.



Product length, mm	1080
Product width, mm	485
Product height, mm	450
Max. free fall height, mm	450
Safety info	EN 16630, EN 1176-1 TÜV
Installation time (for 1), H	1
Foundation options	deep_mounting surface_mounting
Wood	

