

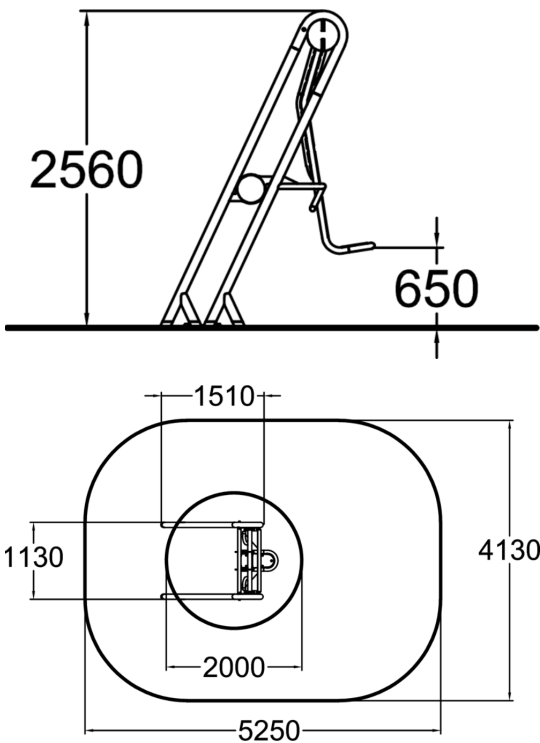

The Chest equipment can be used for push-up-like exercises. They train the chest, shoulder and arm muscles which are needed in daily life, for instance to lift various things. All moving parts are equipped with ball bearings, which ensure pleasant movements for the user. Ball bearings also guarantee a long product life. Chest can be installed on loose fill material also.



Number of users	1
Product length, mm	1510
Product width, mm	1130
Product height, mm	2560
Height required, mm	2150
Max. free fall height, mm	650
Safety info	EN 16630 TÜV
Foundation options	surface_mounting
Metal	