

Cross Trainer

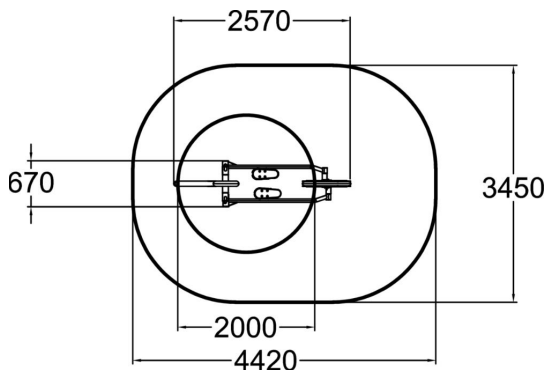

Traditional cross-trainer intended for outdoor use. It is perfect for providing aerobic training at the exerciser's own pace. Aerobic training helps with weight loss and works to prevent some of the lifestyle diseases arising from excess weight, which can hamper everyday activities and shorten life expectancy. Cross-training works and strengthens many of the body's main joints. The device is perfect for a warm-up prior to other exercise. Cross trainer can be installed on loose fill material also.

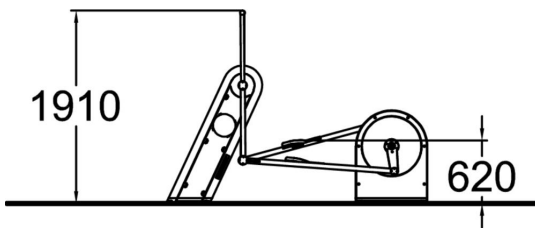

Number of users	1
Product length, mm	2570
Product width, mm	670
Product height, mm	1910
Height required, mm	2820
Max. free fall height, mm	620
Safety info	EN 16630 TÜV
Installation time (for 1), H	2
Foundation options	Surface mounting